

Walk and Bike *Safely*

Student Workbook

Beginning Level for Adult English Language Learners

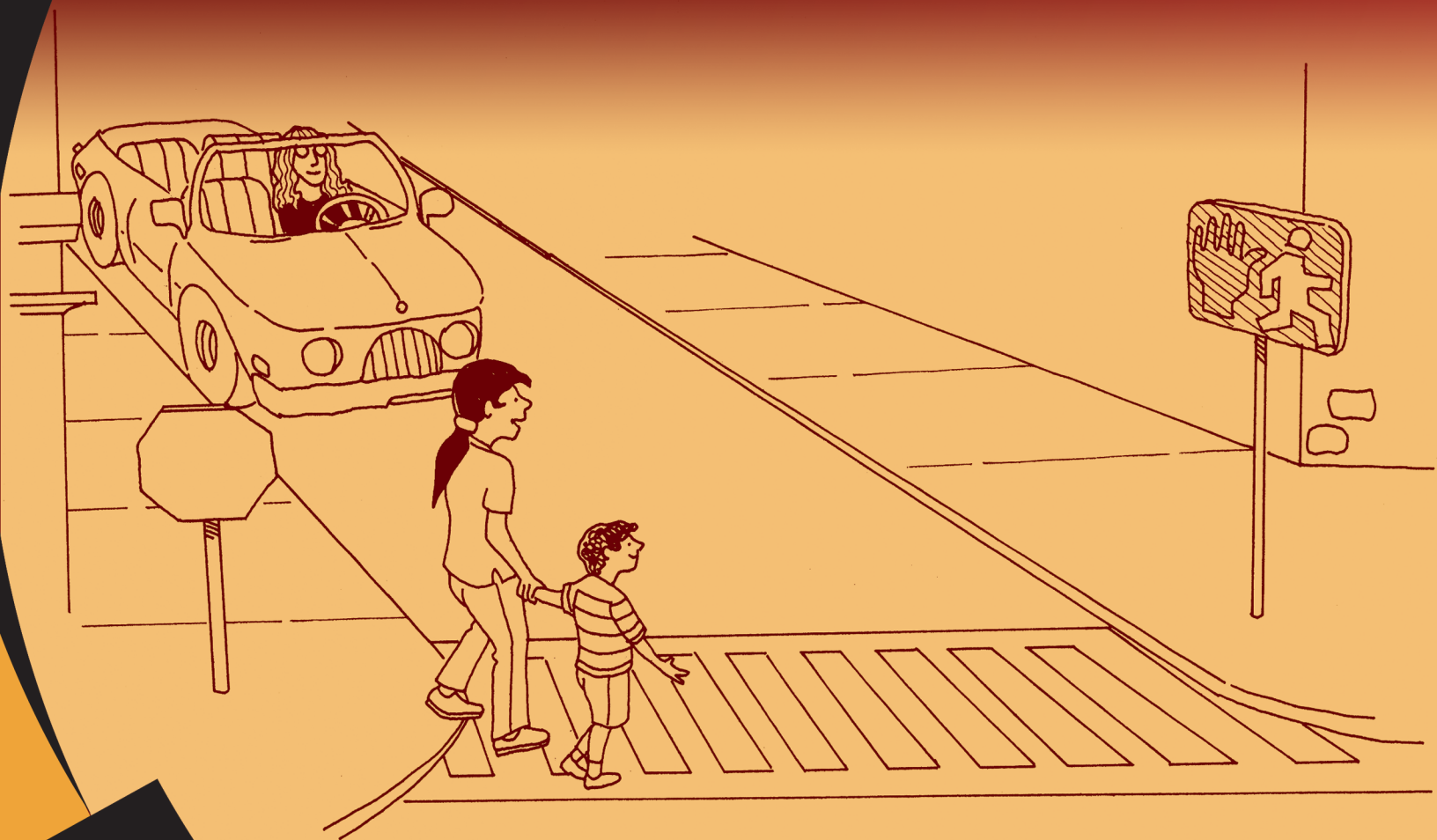

This document was developed by the Center for Applied Linguistics in collaboration with ASPIRA Association, Inc., with funding from the National Highway Traffic Safety Administration (NHTSA). The opinions expressed herein do not necessarily represent the positions or policies of the U.S. Department of Transportation, and no official endorsement by the government should be inferred.



Introduction for Students

This workbook, *Walk and Bike Safely: Beginning Level for Adult English Language Learners*, is for you and your family. Roads in the United States can be dangerous. If you walk or bike near roads, you must be careful. You must pay attention to traffic. You must watch your children. This workbook will help you learn about walking and biking safely in your community.

New Words

There are many important words in this workbook. Read these words before you begin. Which ones do you know? Which ones are new? When you learn the meaning of a word, write it here next to the word. You can write the meaning in English or in your native language.

Lesson 1:

New Word	Notes
car	
cell phone	
to cross	
crosswalk	
curb	
dangerous	
driver	
intersection	
road	
safe	
sidewalk	
to text	
traffic	
to walk	



Lesson 2:

New Word	Notes
child	
driveway	
hold hands	
pedestrian	
play	
sign	
signal	
stop	
wait	
watch	

Lesson 3:

New Word	Notes
bright color	
cloudy	
dark	
evening	
flashlight	
morning	
night	
rainy	
reflective tape	
see	
visible	



Lesson 4:

New Word	Notes
back	
bicycle/bike	
buckle	
fit	
front	
hand	
handlebars	
headlight	
helmet	
loose	
reflector	

Lesson 5:

New Word	Notes
bicyclist	
crash	
light	
obey	
ride	
sign	
signal	
traffic	
yield	



Lesson 6:

New Word	Notes
car door	
dangers	
gravel	
pothole	
rules	
slow	



Lesson 1

Walk *Safely* – Be Careful





Activity 1a

Instructions: Look at the picture. Answer the questions.

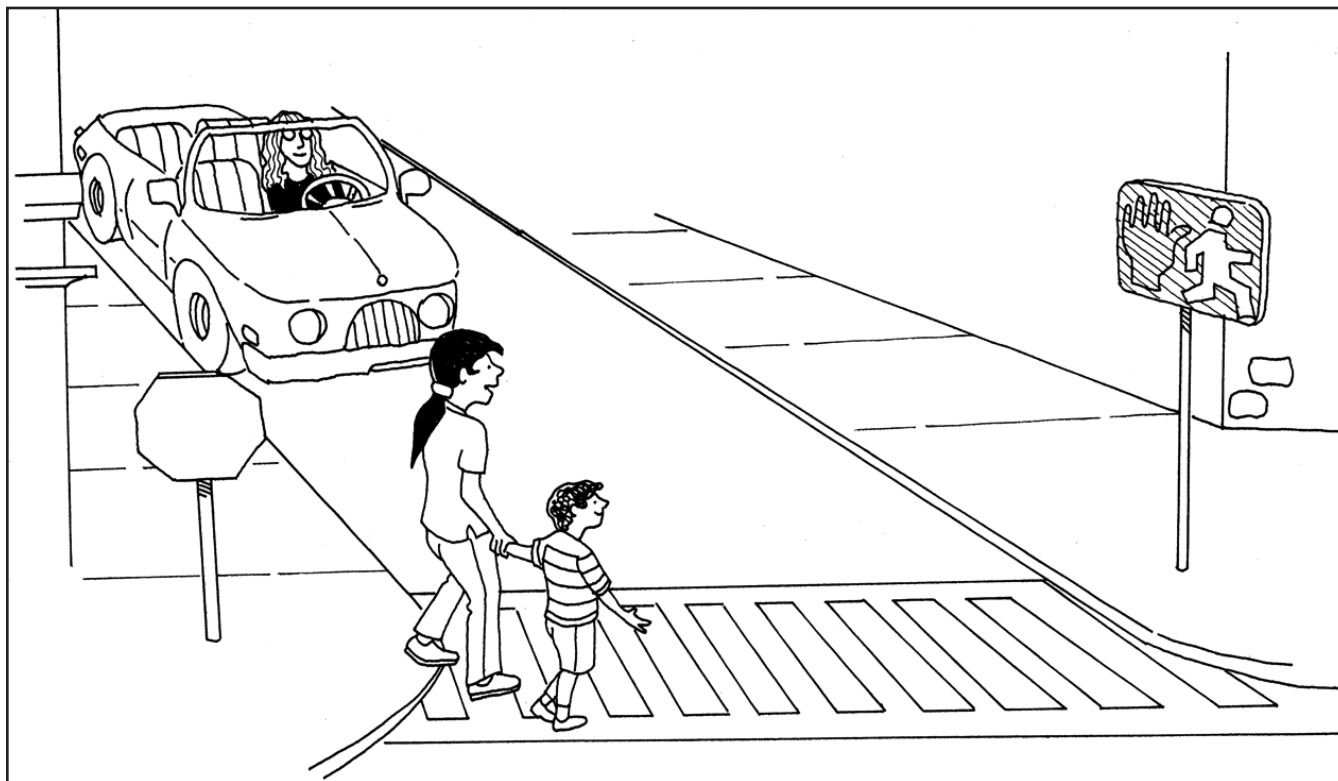

1. What do you see?
2. What are they doing?



Activity 1b

Instructions: Draw a line to match the picture with the word.

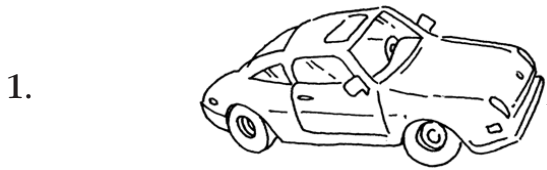

curb

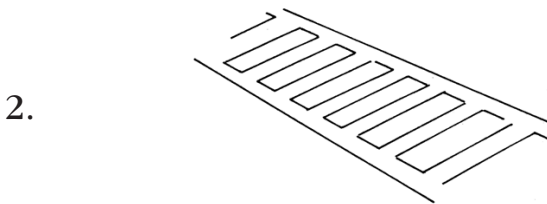

intersection

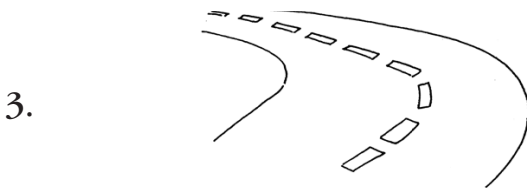

car

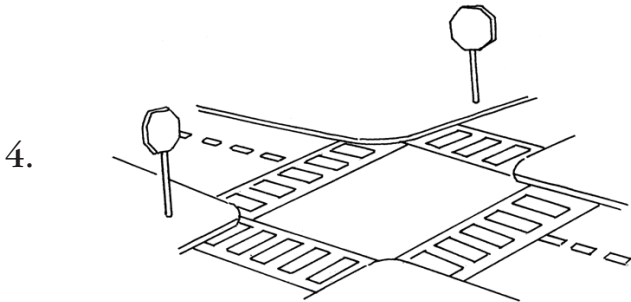

sidewalk

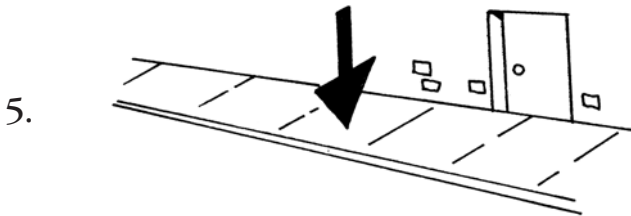

crosswalk

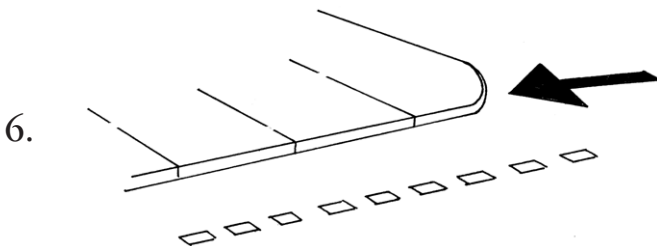

road



Activity 1c

Instructions: Look at the pictures. Listen as your teacher reads the story.



Story:

1. Carmen is crossing the road.
2. The driver doesn't see her.

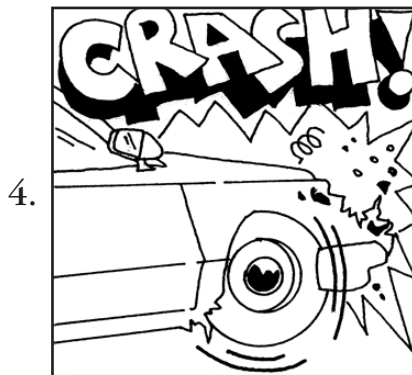

3. Oh no! A car!
4. The car hits Carmen.



5. Carmen goes to the hospital.
6. She is hurt.



Activity 1d

Instructions: Listen to the conversation. Then, based on the drawings, have new conversations with a partner.

1.



A: Hey, be careful! You're in the road. Don't talk on the cell phone!

B: Why?

A: Because it's dangerous.

2.



A: Hey, be careful! You're in the road.

Don't _____!

B: Why?

A: Because it's dangerous.



3.

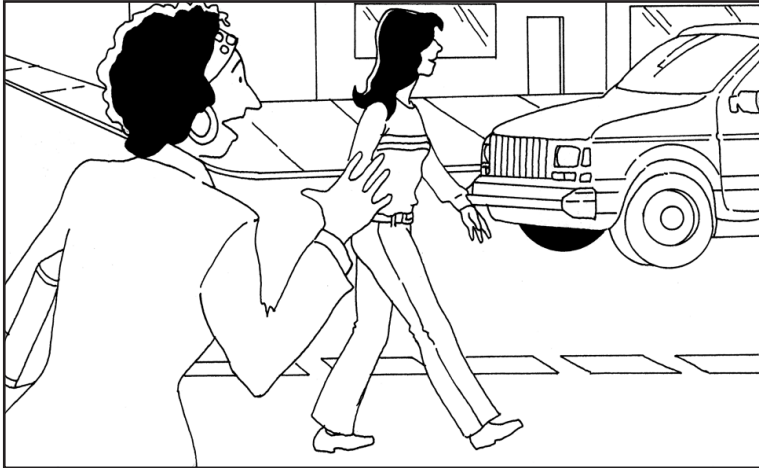

A: Hey, be careful! You're in the road.

Don't _____ !

B: Why?

A: Because it's dangerous.

4.

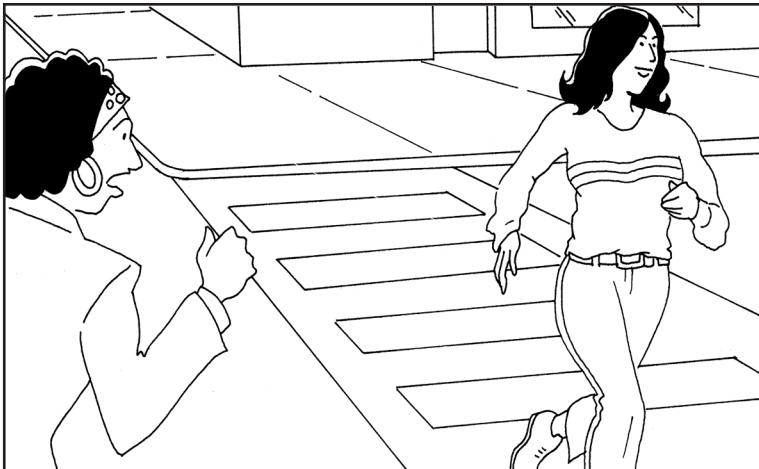

A: Hey, be careful! You're in the road.

Don't _____ !

B: Why?

A: Because it's dangerous.



5.

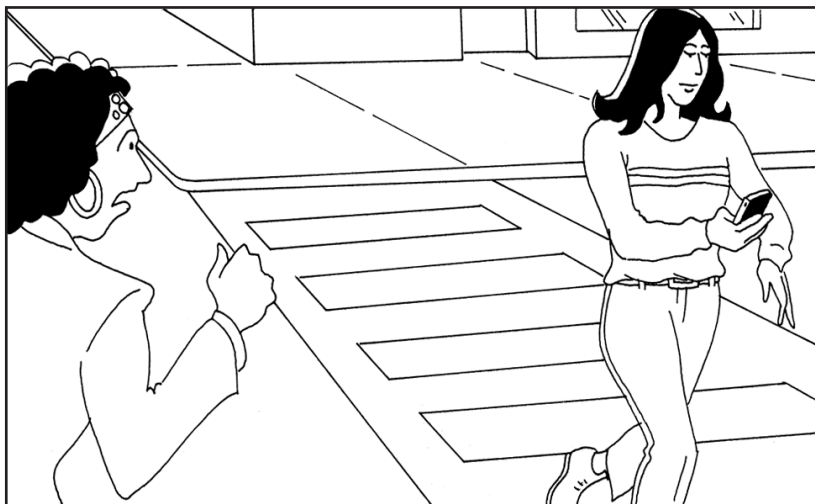

A: Hey, be careful! You're in the road.

Don't _____!

B: Why?

A: Because it's dangerous.



Activity 1e

This activity reviews what we have learned in
Lesson 1: Walk *Safely* – Be Careful.

Instructions: Fill in the blanks with words from the box.
Complete the safety rules.

cell phone	look	
sidewalk	crosswalk	traffic

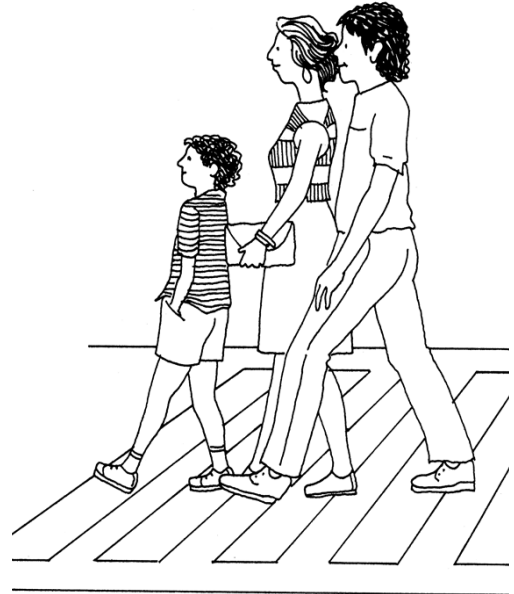

1. Be careful around _____.
2. Walk on the _____.
3. Cross the road in the _____.
4. When you cross the road, _____ left, right, and left for traffic.
5. When you cross the road, do not talk on the _____.



Lesson 2

Walk *Safely* – Watch Children Near Roads





Activity 2a

Instructions: Look at the pictures. Answer the questions.

1.

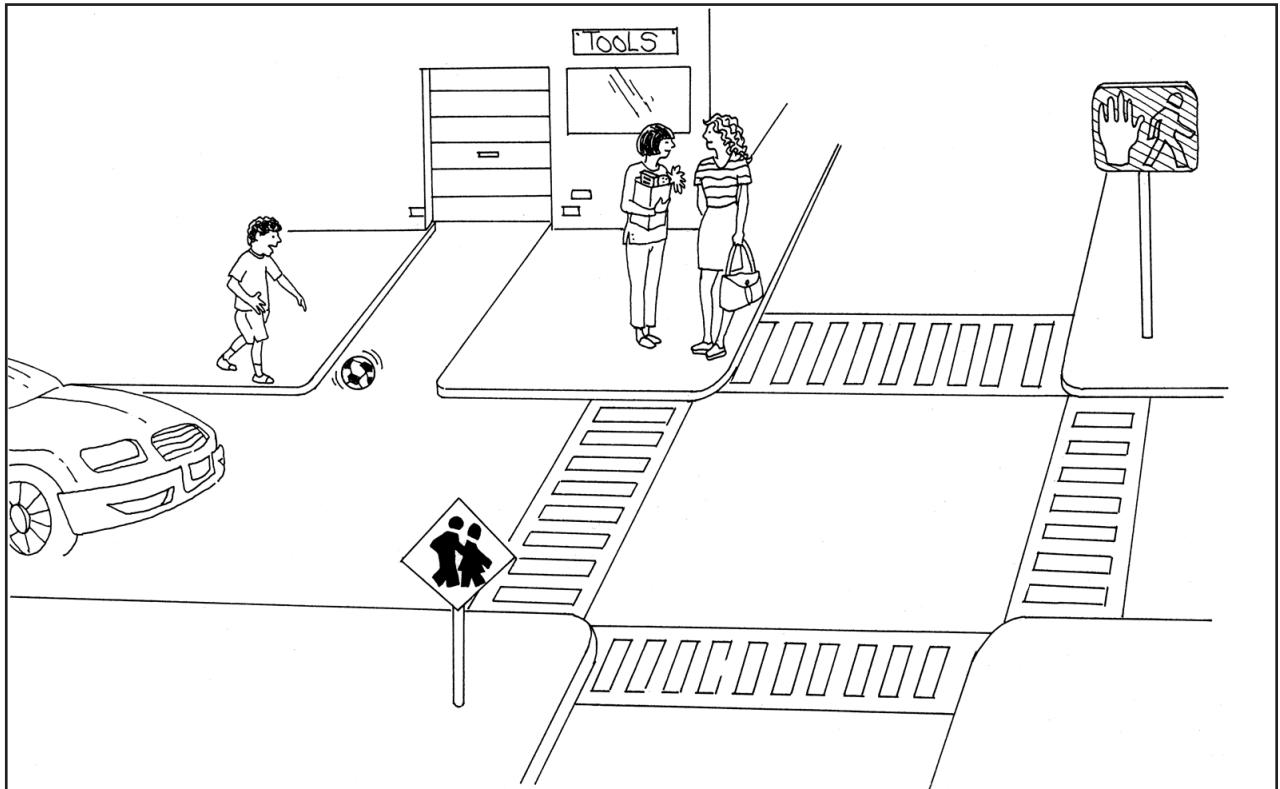

1. What do you see?

2. What is dangerous in the picture?

3. What do the signs and signals mean?



2.



3.

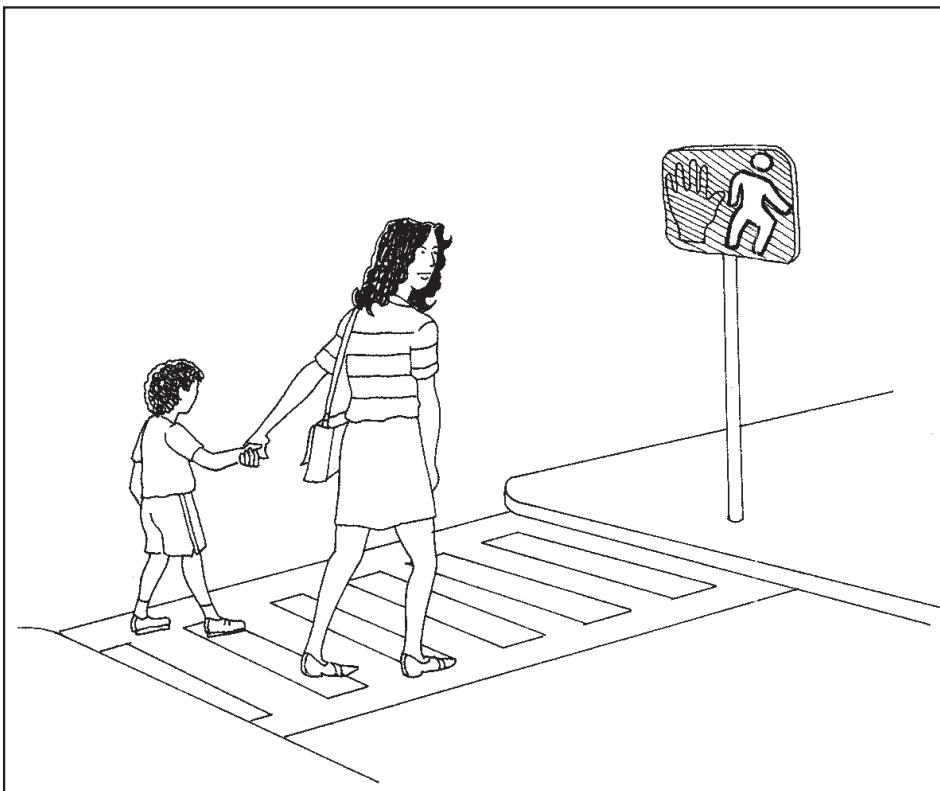



Activity 2b

Instructions: Draw a line to match the picture with the word.



walk

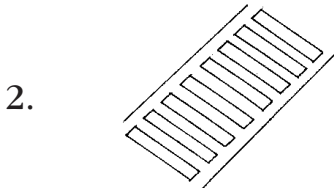

child

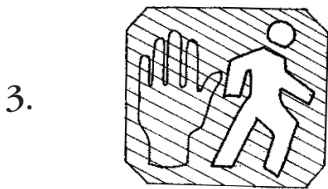

stop sign

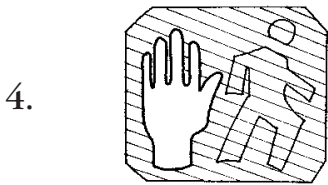

driveway

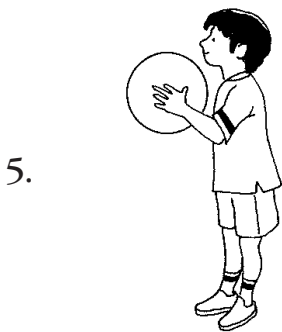

crosswalk

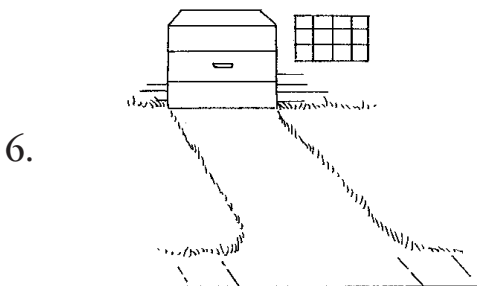

don't walk



Activity 2c

Instructions: Look at the pictures. Discuss the story. Then, listen to the conversation.

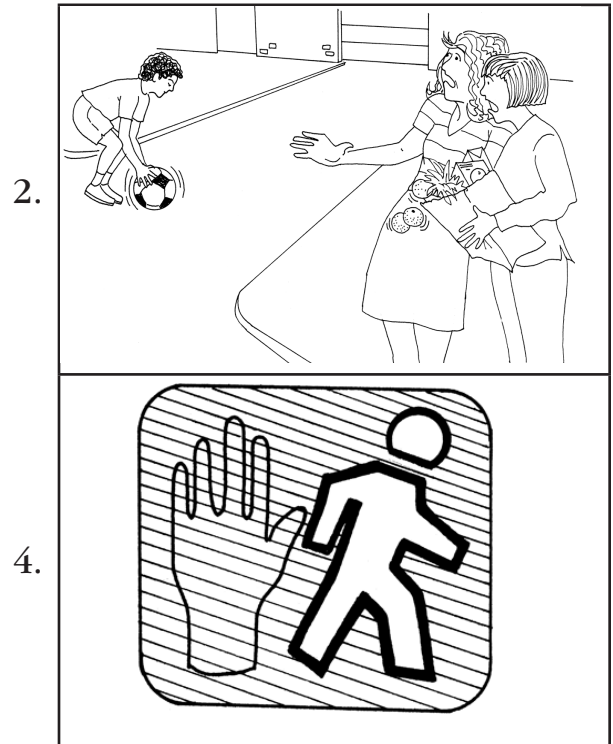
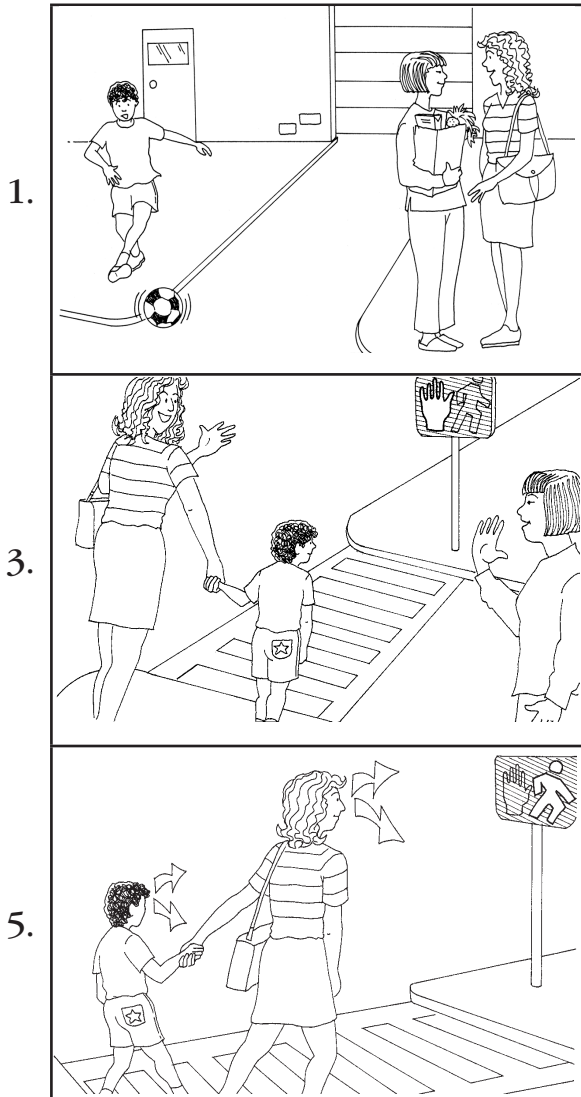

Nati: Samuel, come here! Don't play in the _____!

Samuel: I'm coming, Mom.

Nati: Hold my _____ and stop at the _____.

Let's wait for the _____ signal.



Activity 2d

Instructions: Listen to your teacher explain the rules for Bingo. Play the game!

BINGO!



Activity 2e

This activity reviews what we have learned in
Lesson 2: Walk *Safely* - Obey Signs and Signals.

Instructions: Fill in the blanks with words from the box.
Complete the safety rules.

driveways	hands
watch	signals

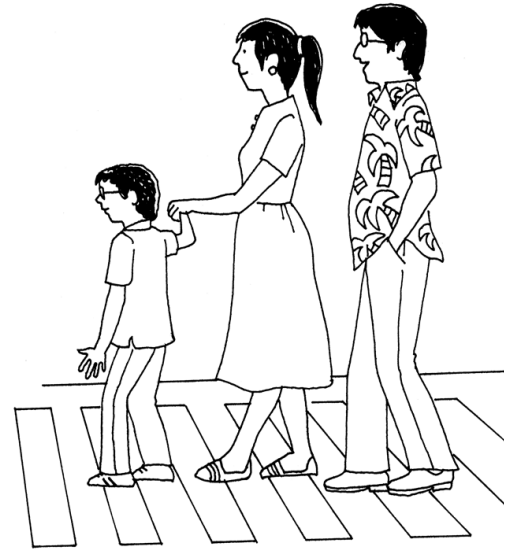

1. Obey the pedestrian signs and _____.
2. When you cross the street, hold _____ with your child.
3. Do not let your child play in _____ and roads.
4. Always _____ children around roads.



Lesson 3

Walk *Safely* - Be Visible

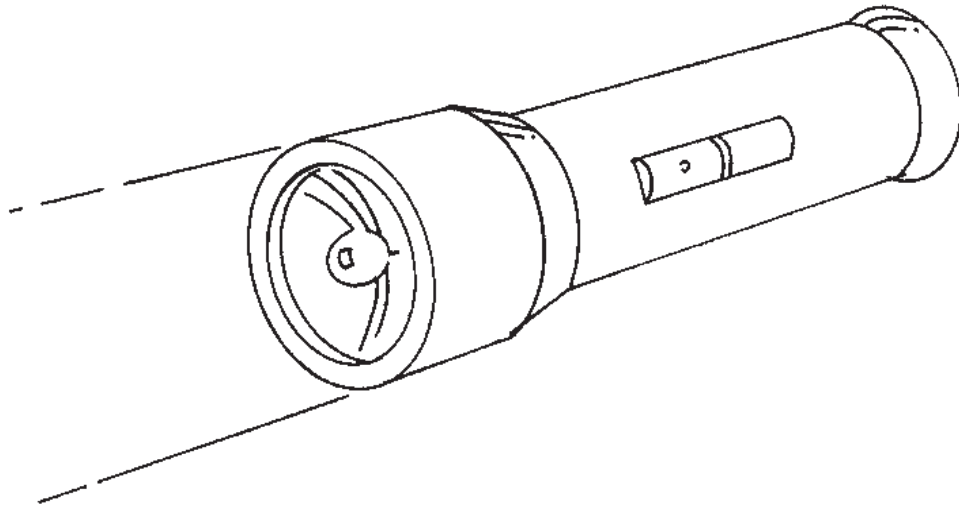



Activity 3a

Instructions: Look at the picture. Answer the questions.





1. What do you see?
2. How is the weather?
3. What is dangerous in the picture?



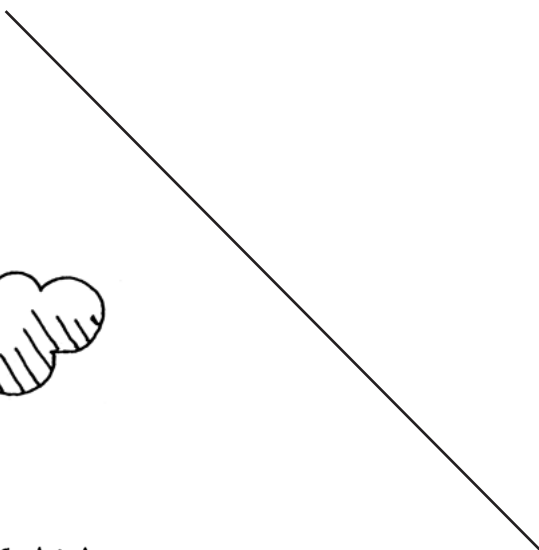

Activity 3b

Instructions: Draw a line to match the picture with the word.

1.   rainy

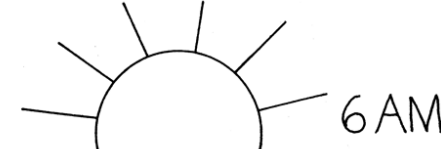
2.  cloudy

3.  6 AM morning

4.  6 PM evening

5.  night



Activity 3c

Instructions: Interview three other students. Check (✓) YES or NO.

Partner's Name	Yes	No
Do you have bright clothing?	_____	_____
Do you have a flashlight?	_____	_____
Do you have reflective tape?	_____	_____

Partner's Name	Yes	No
Do you have bright clothing?	_____	_____
Do you have a flashlight?	_____	_____
Do you have reflective tape?	_____	_____

Partner's Name	Yes	No
Do you have bright clothing?	_____	_____
Do you have a flashlight?	_____	_____
Do you have reflective tape?	_____	_____



Activity 3d

Instructions: Read the information on the reflective tape package.

1. Underline the words you know.
2. Write the words you know here:

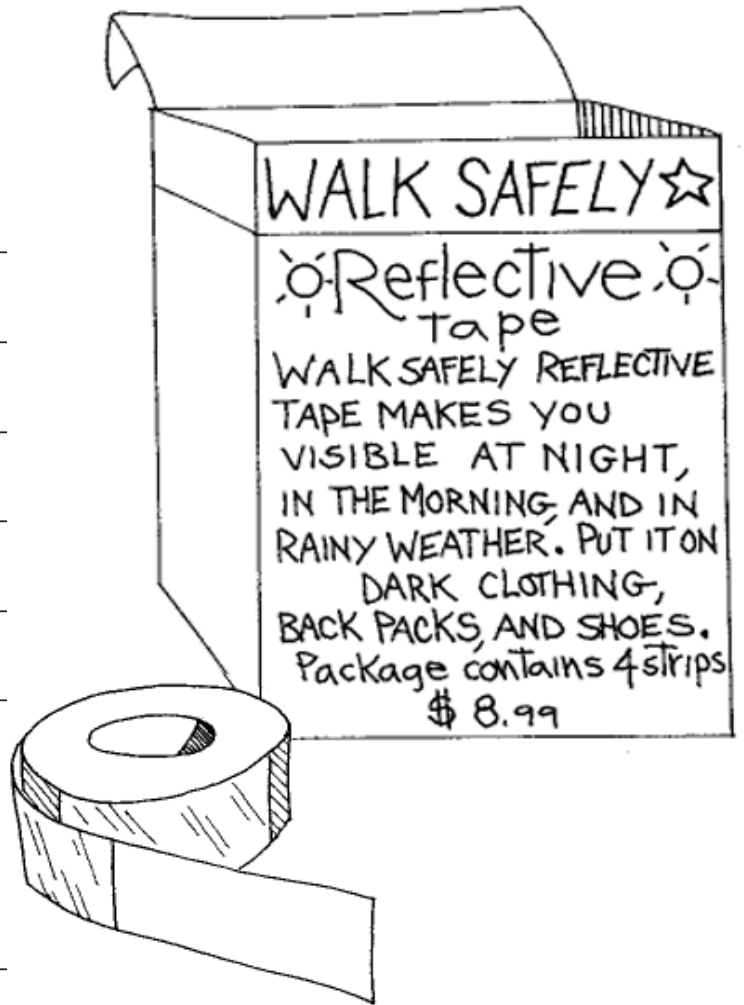

3. Circle the places you should put the tape to make yourself more visible:

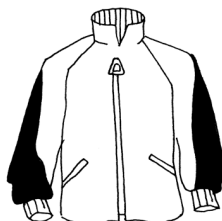
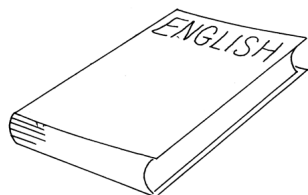



Activity 3e

This activity reviews what we have learned in
Lesson 3: Walk *Safely* - Be Visible.

Instructions: Fill in the blanks with words from the box.
Complete the safety rules.

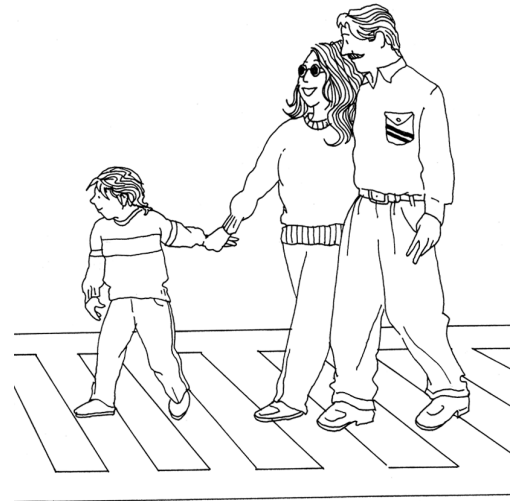

bright	rainy	
flashlight	reflective tape	drivers

1. Sometimes, _____ don't see pedestrians.
2. It is difficult to see pedestrians in _____ weather.
3. Wear _____ clothing.
4. Use a _____ at night.
5. Put _____ on clothes, shoes,
and backpacks.



Lesson 4

Bike Safely - **Use Safe Gear**





Activity 4a

Instructions: Look at the picture. Answer the questions.

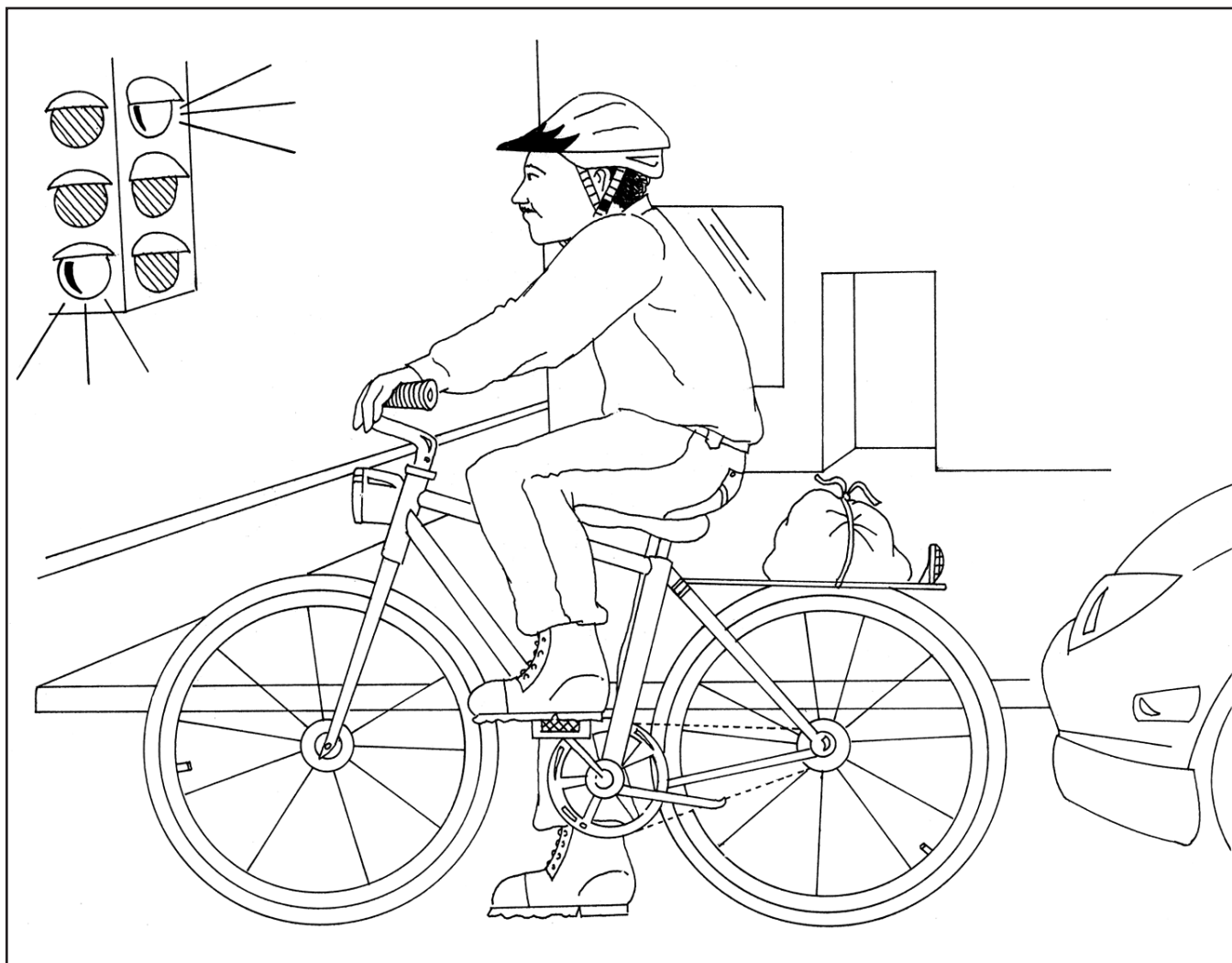

1. What do you see?

2. What is he doing?



Activity 4b

Instructions: Draw a line to match the picture with the word.

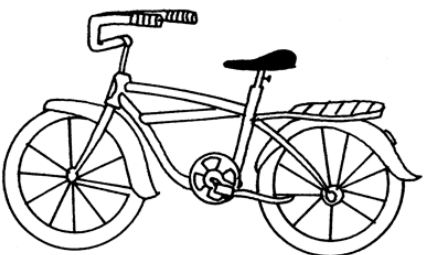
1.  helmet

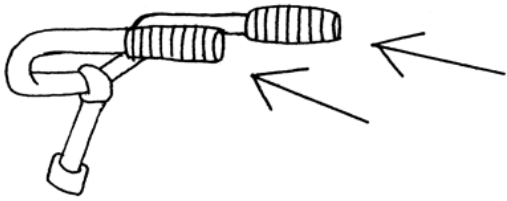
2.  headlight

3.  bicycle

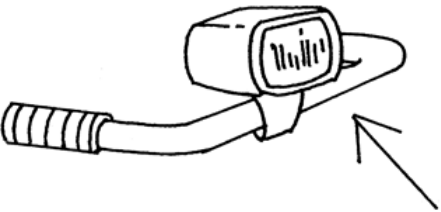
4.  handlebars

5.  reflector



Activity 4c

Instructions: Read the directions below. Then, tell or show your partner how to make sure a helmet and bike fit.

1. How do you put on your helmet?

Cover the forehead.



Make a V under the ears.



Fasten the buckle.



2. Does his bike fit?



His feet touch the ground. The bike fits!



Activity 4d

Instructions: Look at the picture. Listen to the conversation. Fill in the blanks.



Officer Oveda: Make sure the helmet _____.

Nati: How?

Officer Oveda: Put only two fingers between his eyebrows and the _____ . Then, buckle the helmet.

Nati: Okay. Like this?

Officer Oveda: Yes. Make sure it isn't too _____.



Activity 4e

This activity reviews what we have learned in **Lesson 4: Bike Safely – Use Safe Gear.**

Instructions: Fill in the blanks with words from the box. Complete the safety rules.

reflector	fit	
handlebars	helmet	headlight

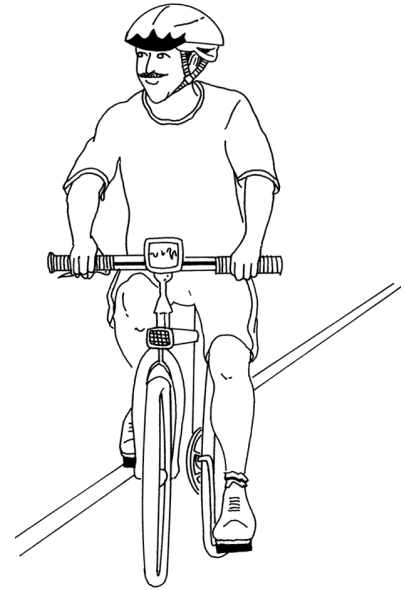

1. When you ride a bicycle, wear a _____.
2. Make sure your helmet and your bicycle _____.
3. Use a _____ on the front of the bicycle at night.
4. Look for a red _____ on the back of the bicycle.
5. Keep two hands on the _____.



Lesson 5

Bike Safely - Follow Traffic Rules

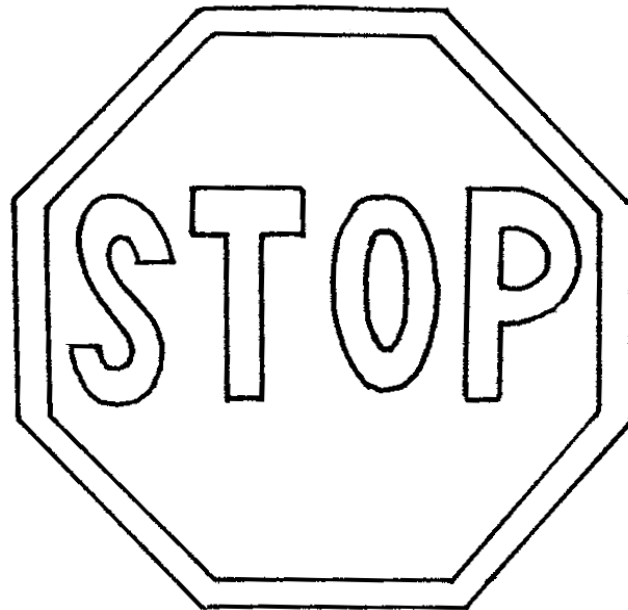



Activity 5a

Instructions: Look at the pictures of traffic signs and signals. Answer the question.

1.



Stop

2.



Traffic goes one way only
in the direction of arrow

3.



Pedestrians cross here

4.

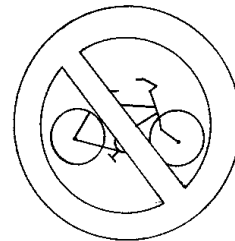

No bicycles

5.

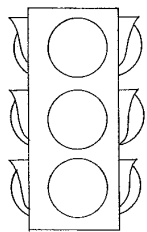

Traffic signal

1. What signs and signals do you see in your neighborhood?



Activity 5b

Instructions: Draw a line to match the picture with the word.

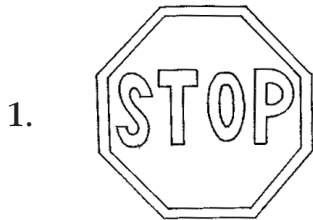

Pedestrians cross here

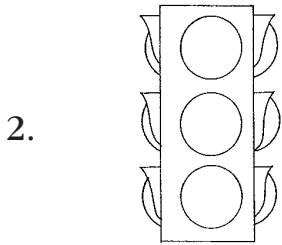

Stop sign

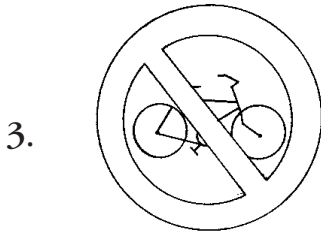

Traffic signal

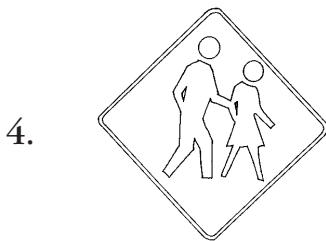

No bicycles

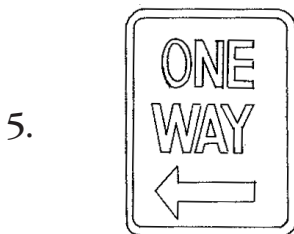

Traffic goes one way only



Activity 5c

Instructions: Look at the pictures. Listen to your teacher read the story.

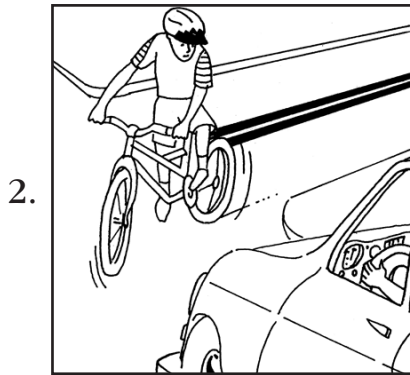
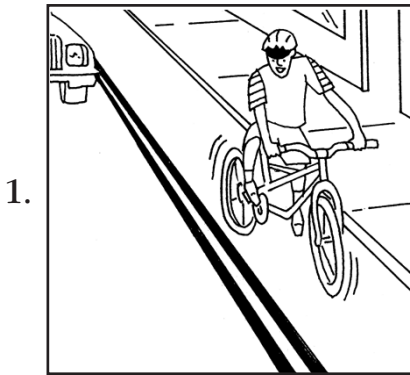

Story:

1. David is riding his bicycle.
2. David is riding on the left side of the road.

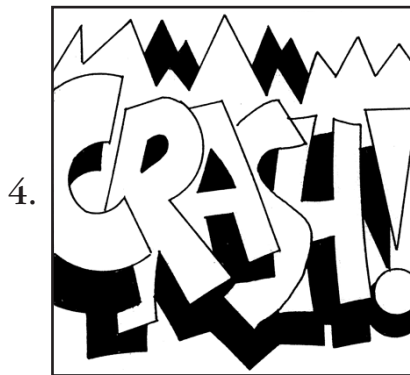

3. The driver sees David, but it is too late.
4. Crash!



5. Officer Oveda talks to David.



Activity 5d

Instructions: Listen to your teacher read the conversation. Look at the new pictures. Have new conversations with a partner.

1.



Who is the police officer?

Who is the boy?

What are they talking about?

2.

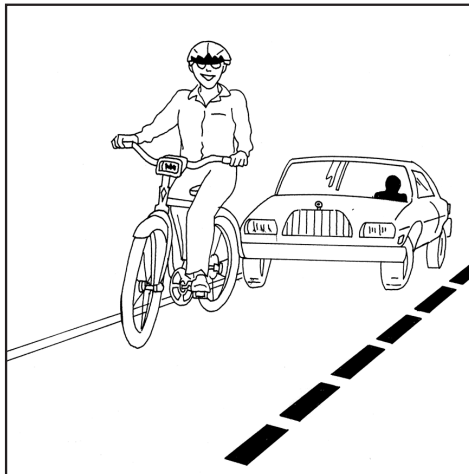

Officer Oveda: David, bicyclists must obey traffic laws, just like drivers.

David: Oh. I didn't know that.

Officer Oveda: Ride on the right side of the road. And be careful!

David: I will. I'm sorry.



3.

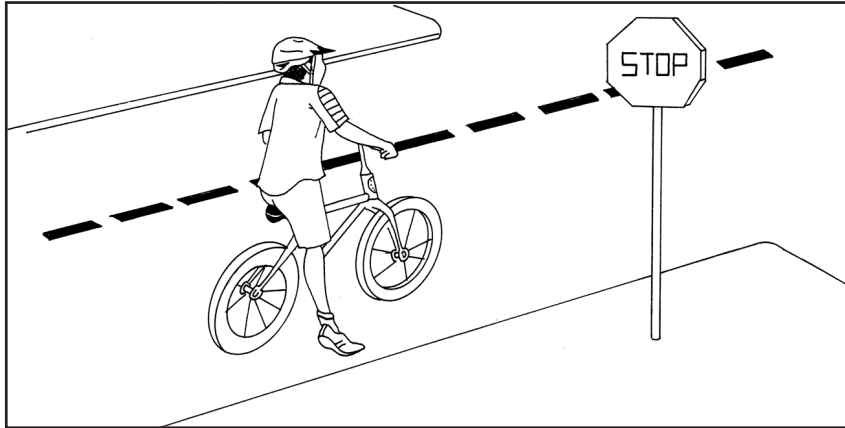

Officer Oveda: David, bicyclists must obey traffic laws, just like drivers.

David: Oh. I didn't know that.

Officer Oveda: _____ . And be careful!

David: I will. I'm sorry.

4.

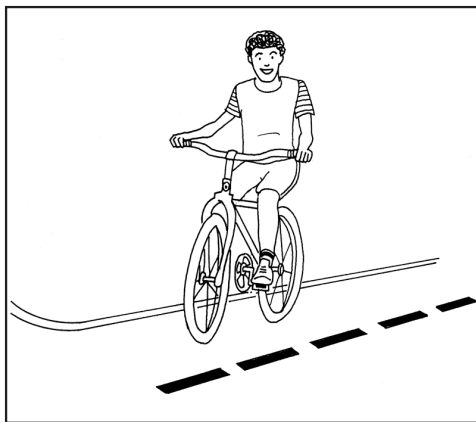

Officer Oveda: David, bicyclists must obey safety rules.

David: Oh. I didn't know that.

Officer Oveda: _____ .
And be careful!



5.

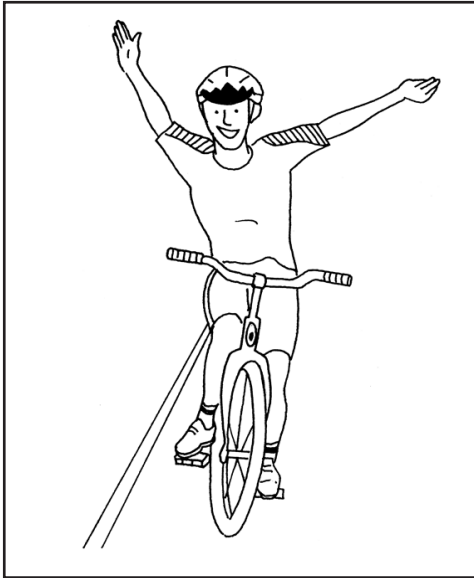

Officer Oveda: David, bicyclists must obey safety rules.

David: Oh. I didn't know that.

Officer Oveda: _____
And be careful!



Activity 5e

This activity reviews what we have learned in **Lesson 5: Bike Safely - Follow Traffic Rules.**

Instructions: Fill in the blanks with words from the box. Complete the rules for bicycling safely.

helmet	stop
right	traffic obey

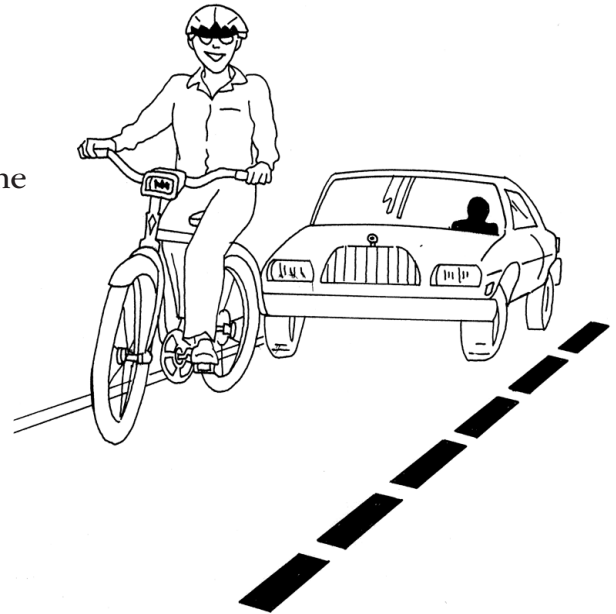

1. Ride your bicycle on the _____ side of the road.
2. _____ traffic signs and signals.
3. _____ for pedestrians in the crosswalk.
4. When you bike, watch for _____.
5. Every time you ride a bicycle, wear a _____.



Lesson 6

Walk and Bike *Safely* - Pay Attention





Activity 6a

This lesson reviews what we have learned in **Lesson 6: Walk and Bike Safely – Pay Attention.**

Instructions: Look at the picture. Answer the questions.

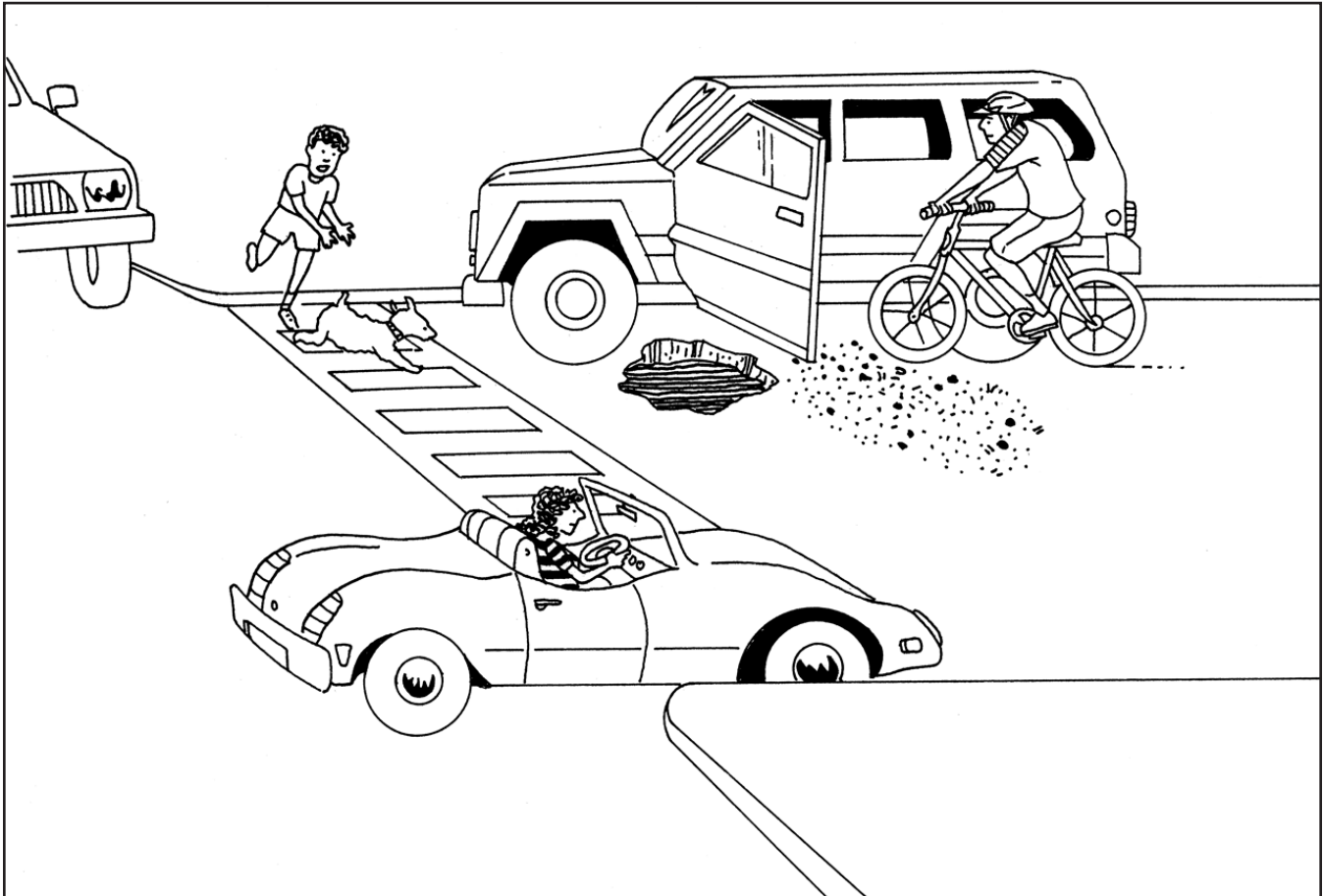

1. What do you see?

2. What are the dangers? Circle them.



Activity 6b

Instructions: Draw a line to match the picture with the word.

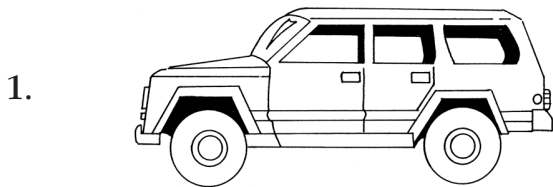

pothole

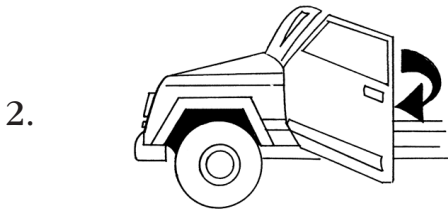

child



car



open car door

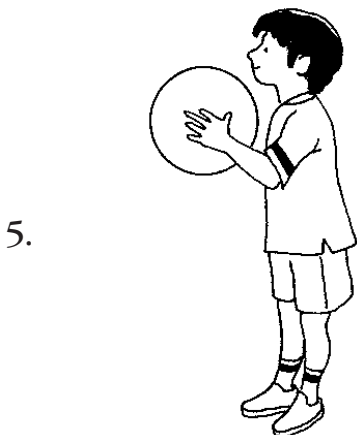

gravel



Activity 6c

Instructions: Listen as your teacher explains the rules for Bingo. Play the game!

BINGO!



Activity 6d

Instructions: Write the safety rule for each picture.

1.

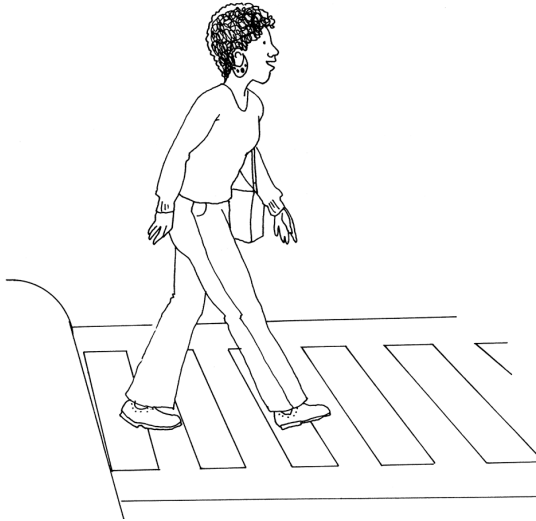

Cross _____.

2.



Wear _____.



3.



Walk _____.

4.

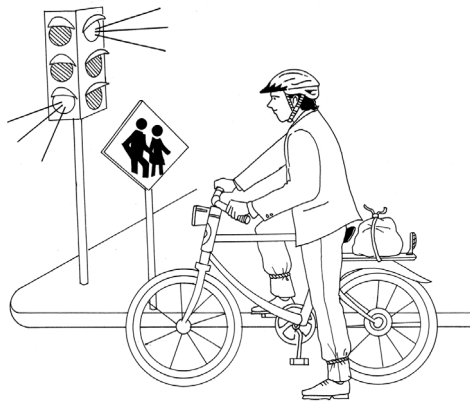

Obey _____.

5.

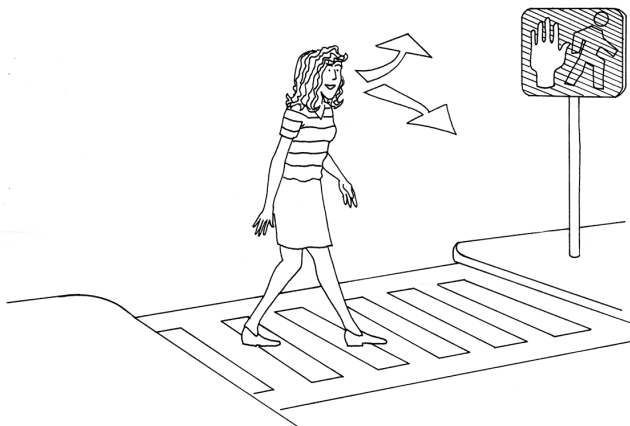

Look _____.

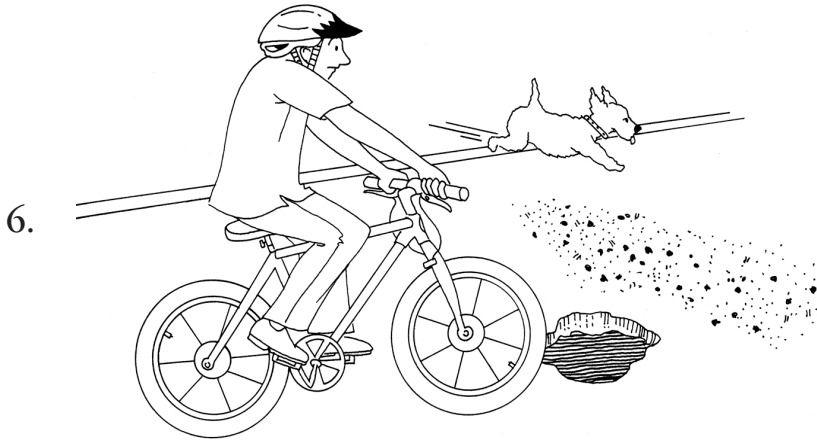

Watch _____.

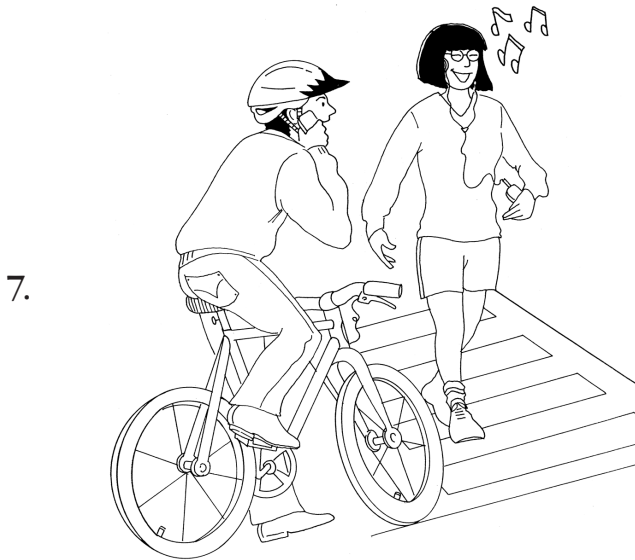

Don't _____.

Don't _____.