

**APPENDIX A**

**PART 572E (50<sup>th</sup> Male) DUMMY PERFORMANCE CALIBRATION TEST PROCEDURE**

**APPENDIX A**  
**PART 572 SUBPART E DUMMY PERFORMANCE CALIBRATION TEST PROCEDURE**

**TABLE OF CONTENTS**

	<b>PAGE</b>
1. PURPOSE AND APPLICATION .....	A-1
2. GENERAL REQUIREMENTS .....	A-1
3. SECURITY .....	A-3
4. GOOD HOUSEKEEPING .....	A-3
5. TEST SCHEDULING AND MONITORING.....	A-3
6. TEST DATA DISPOSITION .....	A-3
7. GOVERNMENT FURNISHED PROPERTY (GFP).....	A-4
8. CALIBRATION AND TEST INSTRUMENTATION.....	A-4
9. PHOTOGRAPHY .....	A-5
10. DEFINITIONS .....	A-5
11. PRETEST REQUIREMENTS.....	A-6
11.1    TRANSDUCER REQUIREMENTS.....	A-6
11.2    OTHER TRANSDUCER CONDITIONS.....	A-7
11.3    THORAX IMPACTOR PROBE .....	A-8
11.4    KNEE IMPACTOR PROBE .....	A-8
11.5    GENERAL TEST CONDITIONS.....	A-11
12. CALIBRATION TEST EXECUTION .....	A-11
13. POST TEST REQUIREMENTS .....	A-11
14. REPORTS .....	A-11
14.1    APPARENT TEST FAILURE .....	A-11
14.2    FINAL PERFORMANCE CALIBRATION REPORTS .....	A-12
15. DATA SHEETS .....	A-15
A1      DUMMY DAMAGE CHECKLIST .....	A-15
A2      EXTERNAL MEASUREMENTS .....	A-17
A3      HEAD DROP TEST .....	A-24
A4      NECK FLEXION TEST .....	A-28
A5      NECK EXTENSION TEST .....	A-31
A6      THORAX IMPACT TEST .....	A-38
A7      LEFT KNEE IMPACT TEST .....	A-43
A8      RIGHT KNEE IMPACT TEST .....	A-45
A9      HIP JOINT-FEMUR FLEXION TEST.....	A-48
A10    INSTRUMENTATION CALIBRATION INFORMATION .....	A-54

**ILLUSTRATIONS**

	<b>PAGE</b>
1A. PART 572E TEST DUMMY.....	A-2
2A. SIGN CONVENTION.....	A-9
3A. EXTERNAL DIMENSIONS SPECIFICATIONS.....	A-21
4A. EXTERNAL DIMENSIONS TEST SETUP -- FRONT VIEW .....	A-22
5A. EXTERNAL DIMENSIONS TEST SETUP -- SIDE VIEW .....	A-23
6A. HEAD DROP TEST SPECIFICATION .....	A-26
7A. HEAD DROP TEST SETUP .....	A-27
8A. NECK PENDULUM SPECIFICATIONS .....	A-34
9A. NECK FLEXION TESTSETUP SPECIFICATIONS.....	A-35
10A. NECK EXTENSION TEST SETUP SPECIFICATIONS .....	A-36
11A. ROTATION TRANSDUCER ASSEMBLY .....	A-37
12A. THORAX IMPACT TEST SPECIFICATIONS.....	A-41
13A. THORAX HYSTERESIS.....	A-42
14A. KNEE IMPACT SETUP TEST SPECIFICATIONS.....	A-47
15A. PELVIC BONE STABILIZER INSERT .....	A-50
16A. PELVIS UPPER SUPPORT DEVICE.....	A-50
17A. HIP JOINT TEST FIXTURE ASSEMBLY .....	A-51
18A. HIP JOINT TEST FIXTURE AND TORSO ASSEMBLY, FRONT VIEW .....	A-52
19A. HIP JOINT TEST FIXTURE AND TORSO ASSEMBLY, SIDE VIEW .....	A-53

**TABLES**

1A. SIGN CONVENTION FOR HYBRID III TRANSDUCER OUTPUTS .....	A-10
---	------

## 1. PURPOSE AND APPLICATION

The purpose of this laboratory procedure is to provide dummy users (independent testing laboratories under contract with the Office of Vehicle Safety Compliance) with standard test procedures for performing receiving-inspection and performance calibration tests on the Part 572, Subpart E dummy so that repetitive and correlative test results can be obtained. The following tests have been developed to establish a uniform calibration procedure for all users as the means of verifying the performance of the dummy.

- A. EXTERNAL DIMENSIONS
- B. HEAD DROP TEST (572.32)
- C. NECK FLEXION TEST (572.33)
- D. NECK EXTENSION TEST (572.33)
- E. THORAX IMPACT TEST (572.34)
- F. FEMUR IMPACT TESTS (572.35)
- G. HIP JOINT-FEMUR FLEXION (572.35)

This laboratory procedure for the calibration of Part 572, Subpart E dummies must be used by National Highway Traffic Safety Administration (NHTSA) contract laboratories performing FMVSS 208 testing for the Office of Vehicle Safety Compliance (OVSC).

## 2. GENERAL REQUIREMENTS

The Code of Federal Regulations (49CFR), Parts 571 and 572, was amended to adopt the Hybrid III, 50th Percentile Dummy as the means of determining a vehicle's conformance to the performance requirements of FMVSS 208. Each Part 572, Subpart E dummy used in a compliance test must meet the specifications and performance criteria of Part 572 before and after each vehicle test in order to be an acceptable compliance test tool.

The Part 572, Subpart E Hybrid III 50th Percentile Dummy consists of components and assemblies specified in the drawing and specifications package which is available from Reprographics Technologies, 9000 Virginia Manor, Beltsville, MD 20705, telephone - (301) 419-5069.

# PART 572E TEST DUMMY

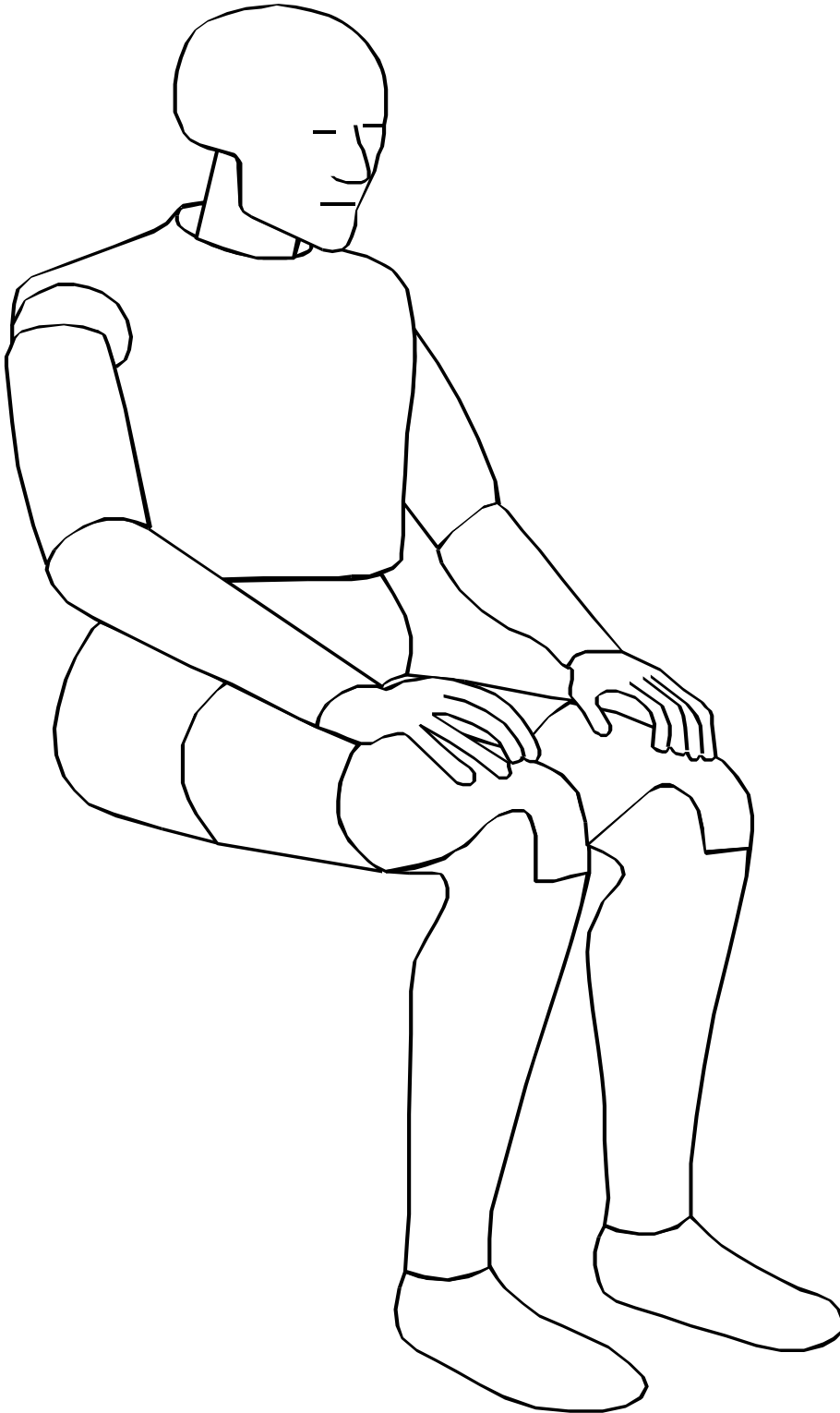

FIGURE 1A

### 3. SECURITY

All NHTSA Part 572, Subpart E test dummies delivered to the contract laboratory as Government Furnished Property (GFP) will be stored in a safe and secure area such as the dummy calibration laboratory. The contractor is financially responsible for any acts of theft and/or vandalism which occur during the storage of GFP. Any security problems shall be reported by telephone to the Industrial Property Manager (IPM), Office of Contracts and Procurement, within two working days after the incident. A letter containing specific details of the security problem will be sent to the IPM (with copy to the COTR) within 48 hours.

The contractor is responsible for maintaining the NHTSA test dummies in good working order, and shall protect and segregate the data that evolves from conducting Part 572, Subpart E dummy calibration tests before and after each vehicle crash usage.

No Information concerning the Part 572E dummy calibration data shall be released to anyone except the COTR, unless specifically authorized by the COTR or the COTR's Branch or Division Chief.

**NOTE:** No Individuals, other than contractor personnel directly involved in the dummy calibration test program, shall be allowed to witness dummy calibration tests unless specifically authorized by the COTR.

### 4. GOOD HOUSEKEEPING

Contractors shall maintain the entire dummy calibration laboratory, test fixtures, and instrumentation in a neat, clean, and painted condition with test instruments arranged in an orderly manner consistent with good test laboratory housekeeping practices.

### 5. TEST SCHEDULING AND MONITORING

The Part 572, Subpart E dummies are being calibrated as test tools to be used in a vehicle test to determine compliance with the requirements of FMVSS 208. The schedule for these performance calibration tests must be correlated with that of the vehicle tests. All testing shall be coordinated to allow monitoring by the COTR.

### 6. TEST DATA DISPOSITION

The contractor shall make all dummy calibration data available to the COTR for review and analysis as required. All calibration test data for each particular Part 572, Subpart E dummy will be sent to the COTR with each test report.

All backup data sheets, strip charts, recordings, plots, technicians notes, etc. shall be either sent to the COTR or destroyed at the conclusion of each delivery order, purchase order, etc.

## **7. GOVERNMENT FURNISHED PROPERTY (GFP)**

P572 test dummies will be furnished to the contract laboratory by the OVSC. The dummies shall be stored in an upright sitting position with the weight supported by the internal structure of the pelvis. The dummies head shall be held upright without supporting the weight of the dummy by using an eyebolt that can be secured in the top of the head. These dummies shall be stored in a secured room that is kept between 55°F and 85°F. The contractor will check dummy components for damage after each crash test and complete a dummy damage checklist (Section 15, Data Sheets) that will be included with the posttest dummy calibration. The COTR will be kept informed of the dummies condition in order that replacement parts can be provided. The contractor shall calibrate the dummies before and verify the calibration after every crash test.

## **8. CALIBRATION AND TEST INSTRUMENTATION**

Before the contractor initiates the dummy performance calibration test program, a test instrumentation calibration system must be implemented and maintained in accordance with established calibration practices. The calibration system shall be set up and maintained as follows:

- A. Standards for calibrating the measuring and test equipment shall be stored and used under appropriate environmental conditions to assure their accuracy and stability.
- B. All measuring instruments and standards shall be calibrated by the contractor, or a commercial facility, against a higher order standard at periodic intervals not exceeding 12 months for instruments and 12 months for calibration standards. Records, showing the calibration traceability to the National Institute of Standards and Technology (NIST), shall be maintained for all measuring and test equipment.
- C. All measuring and test equipment and measuring standards shall be labeled with the following information:
  - (1) Date of calibration
  - (2) Date of next scheduled calibration

- (3) Name of the technician who calibrated the equipment
- D. The contractor shall provide a written calibration procedure that includes, as a minimum, the following information for all measurement and test equipment.
- (1) Type of equipment, manufacturer, model number, etc.
  - (2) Measurement range
  - (3) Accuracy
  - (4) Calibration interval
  - (5) Type of standard used to calibrate the equipment (calibration traceability of the standard must be evident)
  - (6) The actual procedures and forms used to perform calibrations.
- E. The contractor shall keep records of calibrations for all test instrumentation in a manner that assures the maintenance of established calibration schedules. All such records shall be readily available for inspection when requested by the COTR. The calibration system will need the written acceptance of the COTR before testing begins.
- F. Test equipment shall receive a calibration check immediately prior to and after each test. This check shall be recorded by the test technician(s) and submitted with the final report.
- G. Anthropomorphic test devices shall be calibrated before and after each test. These calibrations shall be submitted with the final report.

## **9. PHOTOGRAPHIC DOCUMENTATION**

Provide still photographs (8 x 10 inch glossy color prints properly focused for clear images) of posttest calibration damage resulting from the vehicle crash test.

## **10. DEFINITIONS**

NONE

## 11. PRETEST REQUIREMENTS

### 11.1 TRANSDUCER REQUIREMENTS

The contractor shall provide and install the following instrumentation to the GFP dummies (excluding chest displacement transducer).

- A. HEAD – The head accelerometers shall have dimensions, response characteristics and sensitive mass locations specified in drawing 78051-136, revision A and be mounted in the head as shown in drawing 78051-61X, March 28, 1997, and in the assembly shown in drawing 78051-218, revision T. (572.36(c))

Three Endevco 7231C-750 accelerometers with 1% Transverse Sensitivity shall be mounted in the head cavity to measure orthogonal accelerations ( $A_x$ ,  $A_y$ ,  $A_z$ ) at the center of gravity (CG) of the head assembly.

- B. NECK – The neck transducer shall have the dimensions, response characteristics, and sensitive axis locations specified in drawing 83-5001-008 or C-1709 and be mounted for testing as shown in drawing 79051-63, revision W, and in the assembly shown in drawing 78051-218, revision T. (572.36(d))

- C. CHEST – The chest accelerometers shall have the dimensions, response characteristics, and sensitive mass locations specified in drawing 78051-136, revision A and be mounted as shown with adaptor assembly 78051-116, revision D for assembly into 78051-218, revision T. The chest accelerometers are not required for dummy calibration testing but are required for FMVSS 208 testing. Three Endevco 7231C-750 accelerometers with 1% Transverse Sensitivity shall be mounted in the chest cavity to measure orthogonal accelerations ( $A_x$ ,  $A_y$ ,  $A_z$ ) at the CG of the chest assembly. (572.36(e))

The chest deflection transducer shall have the dimensions and response characteristics specified in drawing 78051-342, revision A (Bourns Potentiometer Model 6638S-432-102, or alternate Vernitech Potentiometer Model 81422A) and be mounted in the chest deflection transducer assembly 78051-317, revision A for assembly into 78051-218, revision T. (572.36(f))

- D. LEGS -- The single axis femur force transducer shall have the dimensions, response characteristics, and sensitive axis locations specified in drawing 78051-265 (GSE Model 2430) and be mounted in assemblies 78051-46 and -47 for assembly into 78051-218,

revision T. The femur transducers are not required for calibration of the dummy but are required for FMVSS 208 testing. (572.36(h))

- E. TEST FIXTURE – The neck pendulum, thorax and knee probe accelerometers shall have the dimensions and characteristics of Endevco Model 7231C. (572.36(g))

## 11.2 OTHER TRANSDUCER CONDITIONS

### A. TRANSDUCER MOUNTS

The mountings for sensing devices shall have no resonance frequency within range of 3 times the frequency range of the applicable channel class. (572.36(k))

- B. The sign convention for outputs of transducers mounted within the Hybrid III that measure head and chest accelerations, chest deflection and femur loads are located in Figure 2A. For other transducers see SAE J1733DEC94 (Appendix F). (572.36(j) & (572.31(a)(5))

### C. TRANSDUCER OUTPUT FILTERING

The outputs of acceleration and force-sensing devices installed in the dummy and in the test apparatus specified by this part are recorded with individual data channels. Each data channel will be comprised of a sensor, signal conditioner, data acquisition device, and all interconnecting cables, and must conform to the requirements of SAE Recommended Practice J211/1 MAR95, "Instrumentation for Impact Test," with channel classes as follows: (572.36(i))

- (1) Head acceleration – Class 1000 (572.36(i)(1))
- (2) Neck force – Class 1000 (572.36(i)(2)) (For calculation of the moment about the occipital condyle, use filter class 600 for the neck force)
- (3) Neck moments – Class 600 (572.36(i)(3))
- (4) Neck pendulum acceleration – Class 60 (572.36(i)(4))
- (5) Neck rotation transducers - Class 60
- (6) Thorax and thorax pendulum acceleration – Class 180 (572.36(i)(5))
- (7) Thorax deflection - Class 180 (572.36(i)(6))
- (8) Knee pendulum acceleration – Class 600(572.36(i)(7))
- (9) Femur force – Class 600 (572.36(i)(8))
- (10) Hip flexion – Class 60

All filter classes should be of the "phaseless" type to be compatible with the "time" dependent test parameters.

### 11.3 THORAX IMPACTOR PROBE (572.36(a))

- A. The test probe for thoracic impacts is a 6 inch diameter cylinder weighing 51.5 pounds. (572.36(a))
- B. The impacting end of the probe is perpendicular to and concentric with the longitudinal axis. It has an edge radius of 0.5 inches. (572.36(a))
- C. The probe's end opposite to the impact face must have provisions for mounting of an accelerometer with its sensitive axis collinear with the longitudinal centerline of the cylinder. (572.36(a))

### 11.4 KNEE IMPACTOR PROBE

- A. The test probe for thoracic impacts is a 3- inch diameter cylinder weighing 11 pounds including instrumentation. (572.36(b))
- B. The impacting end of the probe is perpendicular to and concentric with the longitudinal axis. It has an edge radius of 0.02 inches. (572.36(b))
- C. The probe's end opposite to the impact face must have provisions for mounting of an accelerometer with its sensitive axis collinear with the longitudinal centerline of the cylinder. (572.36(b))

**TABLE 1A**  
**SIGN CONVENTIONS FOR**  
**PART 572 SUBPART E TEST DUMMIES**

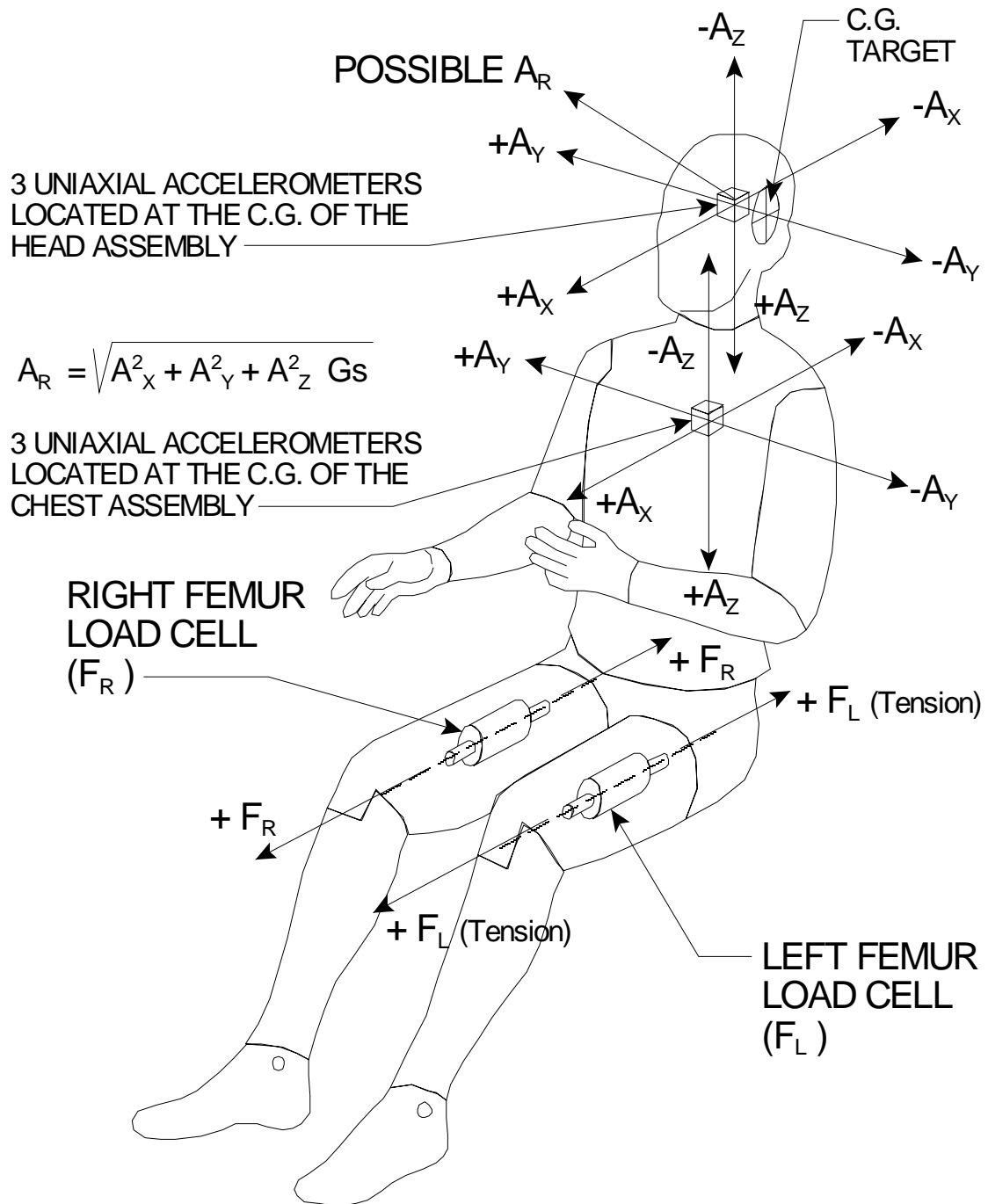

**FIGURE 2A**

<b>SIGN CONVENTION FOR HYBRID III TRANSDUCER OUTPUTS</b>	
<b>BODY SEGMENT — MEASURED FORCE</b>	<b>POSITIVE OUTPUT DIRECTION</b>
NECK FX SHEAR FY SHEAR FZ AXIAL  MX MOMENT (ROLL) MY MOMENT (PITCH) MZ MOMENT (YAW)	HEAD REARWARD OR CHEST FORWARD HEAD LEFTWARD, CHEST RIGHTWARD HEAD UPWARD, CHEST DOWNWARD  LEFT EAR TOWARD LEFT SHOULDER CHIN TOWARD STERNUM CHIN TOWARD LEFT SHOULDER
FEMUR FX SHEAR FY SHEAR FZ AXIAL  MX MOMENT (ROLL) MY MOMENT (PITCH) MZ MOMENT (YAW)	KNEE UPWARD, UPPER FEMUR DOWNWARD KNEE RIGHTWARD, UPPER FEMUR LEFTWARD KNEE FORWARD (TENSION), PELVIS REARWARD  KNEE LEFTWARD, HOLD UPPER FEMUR IN PLACE KNEE UPWARD, HOLD UPPER FEMUR IN PLACE KNEE ROTATED CCW WHEN FACING FRONT OF DUMMY
KNEE CLEVIS - FZ AXIAL	TIBIA DOWNWARD (TENSION), FEMUR UPWARD
UPPER TIBIA MX MOMENT MY MOMENT	ANKLE LEFTWARD, HOLD KNEE IN PLACE ANKLE FORWARD, BOTTOM OF KNEE CLEVIS REARWARD
LOWER TIBIA FX SHEAR FY SHEAR FZ AXIAL  MX MOMENT MY MOMENT	ANKLE FORWARD, KNEE REARWARD ANKLE RIGHTWARD, KNEE LEFTWARD ANKLE DOWNWARD (TENSION), KNEE UPWARD  ANKLE LEFTWARD, HOLD KNEE IN PLACE ANKLE FORWARD, BOTTOM OF KNEE CLEVIS REARWARD
CHEST DISPLACEMENT	CHEST COMPRESSED - NEGATIVE
KNEE SHEAR DISPLACEMENT	PUSH ON FRONT OF TIBIA - NEGATIVE

**NOTE:** DIRECTIONS ARE DEFINED IN RELATION TO A SEATED DUMMY

## **11. PRETEST REQUIREMENTS....Continued**

### **11.5 GENERAL TEST CONDITIONS**

- A. Surfaces of dummy components are not painted unless otherwise specified. (572.36(n))
- B. Dummy performance tests of the same component, segment, assembly, or fully assembled dummy are separated in time by a period of not less than 30 minutes unless otherwise specified. (572.36(m))
- C. Dummy performance tests are conducted at any temperature from 69°F to 72°F unless otherwise specified and at any relative humidity from 10% to 70% after exposure of the dummy to these conditions for a period of not less than 4 hours.
- D. Dummy limb joints are set at 1 g, barely restraining the weight of the limb when it is extended horizontally. The force required to move a limb segment does not exceed 2 gs throughout the range of limb motion. (572.36(l))
- E. Dummies will be clothed for the thorax calibration tests with the exception of the shoes being removed.

## **12. CALIBRATION TEST EXECUTION**

Complete the Data Sheets in section 15.

## **13. POST TEST REQUIREMENTS**

The contractor shall verify all instrumentation and check data sheets and photographs. Make sure data is recorded in all data blocks on every performance calibration test data sheet.

## **14. REPORTS**

### **14.1 APPARENT NONCONFORMANCE**

During the post test calibration, any indication of apparent nonconformance to the requirements of Regulation P572 shall be communicated by telephone to the COTR within 24 hours with written notification mailed within 48 hours (Saturdays and Sundays excluded). Written notification shall be submitted with a copy of the particular test data sheet(s) and preliminary data plot(s).

In the event of an apparent nonconformance, a post test calibration check of some critically sensitive test equipment and instrumentation may be required for verification of accuracy. The necessity for the calibration shall be at the COTR's discretion and shall be performed without additional costs to the OVSC.

## 14.2 FINAL PERFORMANCE CALIBRATION REPORTS

### 14.2.1 COPIES

A report containing the pre-test calibration and post test calibration verification data for each Part 572, Subpart E dummy used in the vehicle compliance test shall be submitted with the FMVSS 208 final test report for the vehicle tested.

Contractors are required to PROOF READ all Final Test Reports before submittal to the COTR. The OVSC will not act as a report quality control office for contractors. Reports containing a significant number of errors will be returned to the contractor for correction, and a "hold" will be placed on invoice payment for the particular test.

### 14.2.2 REQUIREMENTS

Performance calibration report Table of Contents shall include the following:

- A. Section 1 — Purpose of Calibration Test
- B. Section 2 — Calibration Data Summary
- C. Section 3 — Test Data
- D. Section 4 — Test Equipment List and Calibration Information
- E. Section 5 — Photographs (if applicable)

The test data for each dummy will be presented in separate sections. Each section shall contain a title page, test results summary and the test data. The title page shall include the dummy's serial number and the manufacturer's name. It will also indicate whether the calibration data is pre or post test. The test results sheets will provide a summary of each test and describe any damage, failures and/or corrective action taken. The test data shall include the pass/fail data sheets, the time histories for each data channel used to determine the pass or fail status, and instrumentation calibration data sheets.

## 14.2.3 FIRST PAGE

## FRONT COVER

A heavy paperback cover (or transparency) shall be provided for the protection of the final report. The information required on the cover is as follows:

- A. Final Report Title And Subtitle such as

DUMMY PERFORMANCE CALIBRATION  
IN SUPPORT OF  
VEHICLE SAFETY COMPLIANCE TESTING  
FOR OCCUPANT CRASH PROTECTION

- B. Contractor's Name and Address such as



ABC TESTING LABORATORIES, INC.  
405 Main Street  
Detroit, Michigan 48070

**NOTE:** DOT SYMBOL WILL BE PLACED BETWEEN ITEMS B AND C

- C. Date of Final Performance Calibration Report completion

- D. The sponsoring agency's name and address as follows

U. S. DEPARTMENT OF TRANSPORTATION  
National Highway Traffic Safety Administration  
Enforcement  
Office of Vehicle Safety Compliance  
400 Seventh Street, SW  
Room 6111 (NVS-220)  
Washington, DC 20590

**15. Data Sheets**

**DATA SHEET A1**  
**DUMMY DAMAGE CHECKLIST (50<sup>th</sup> Male)**

Dummy Serial Number \_\_\_\_\_ Test Date \_\_\_\_\_

Technician \_\_\_\_\_

This check sheet is completed as part of the post test calibration verification.

Perform general cleaning.

Dummy Item	Inspect for	Comments	Damaged	OK
Outer skin	Gashes, rips, cracks			
Head	Ballast secure			
	General appearance			
Neck	Broken or cracked rubber			
	Upper neck bracket firmly attached to the lower neck bracket			
	Looseness at the condyle joint			
	Nodding blocks cracked or out of position			
Spine	Broken or cracks in rubber.			
Ribs	Broken or bent ribs			
	Broken or bent rib supports			
	Damping material separated or cracked			
	Rubber bumpers in place			
Chest Displacement Assembly	Bent shaft			
	Slider arm riding in track			
Transducer leads	Torn cables			

Dummy Item	Inspect for	Comments	Damaged	OK
Accelerometer Mountings	Head mounting secure			
	Chest mounting secure			
Knees	Skin condition			
	Insert (do not remove)			
	Casting			
Limbs	Normal movement and adjustment			
Knee Sliders	Wires intact			
	Rubber returned to "at rest" position			
Pelvis	Broken			
Other				

If upon visual examination, damage is apparent in any of these areas, the appropriate engineer or engineering technician is to be consulted for a decision on repair or replacement of parts.  
 Repair or Replacement approved by:

\_\_\_\_\_  
 Signature

\_\_\_\_\_  
 Date

Describe the repair or replacement of parts:

Checked by

\_\_\_\_\_  
 Signature

\_\_\_\_\_  
 Date

**DATA SHEET A2**  
EXTERNAL MEASUREMENTS (50<sup>th</sup> Male)  
(Procedures for Disassembly, Inspection  
and Assembly of the Hybrid III Dummy, Appendix A)

Dummy Serial Number \_\_\_\_\_ Test Date \_\_\_\_\_

Technician \_\_\_\_\_

Pretest calibration

Post test calibration verification

1. Remove the dummy's chest jacket and the abdominal insert.
2. Seat the dummy on a flat, rigid, smooth, clean, dry, horizontal surface as shown in Figure 3A. The seating surface is at least 406 mm (16 in) wide and 406 mm (16 in) in depth with a vertical section at least 406 mm (16 in) wide and 914 mm (36 in) high attached to the rear of the seating fixture. The dummy's midsagittal plane is vertical and centered on the test surface.
3. Remove the four socket head cap screws that attach the lumbar spine to the thoracic spine. Lift the upper torso off of the lower torso. Check the torque on the two spine cables. The torque should be 1.2 – 1.4 NM (11 – 12 in-lbs).

**NOTE:** At this point the thorax is to be inspected for damage. The thorax displacement transducer may be removed for calibration if required (pretest calibration only). Extreme caution to be used so as not to damage the instrumentation cables.

4. Reassemble the upper torso to the lower torso.
5. Secure the dummy to the test fixture so that the rear surfaces of the upper thorax and buttock are tangent or as near tangent as possible to the rear vertical surface of the fixture and the dummy's midsagittal plane is vertical.
6. Position the dummy's H-point so it is  $3.4 \pm 0.1$  in above the horizontal seating surface and  $5.4 \pm 0.1$  in forward of the rear vertical surface of the fixture. (Note: the H-point is located 1.83 in. forward and 2.57 in. downward from the center of the pelvic angle reference hole in the lumbar-pelvic adaptor.)
7. Extend the dummy's neck so that the base of the skull is level both fore-and-aft and side-to-side, within 0.5 degrees. The rear surface of the skull cap should be  $1.7 \pm 0.1$  in. from the vertical surface of the test fixture. A strap or bungee cord may be placed around the forehead of the dummy to stabilize the head in this position.
8. Position the upper and lower legs parallel to the midsagittal plane so the centerline between the knee pivot and the ankle pivot is vertical.

- \_\_\_9. Position the feet parallel to the dummy's midsagittal plane with the bottoms horizontal and parallel to the seating surface.
- \_\_\_10. Position the upper arms downward vertically so the centerline between the shoulders and elbow pivots is parallel to the rear vertical surface of the fixture.
- \_\_\_11. Position the lower arms horizontally so the centerline between the elbow and wrist pivots is parallel to the seat surface.
- \_\_\_12. Record the dimensions listed in the following table, except for dimension Y and Z (reference figure 3A).
- \_\_\_13. Install the abdominal insert and chest jacket. Reposition the dummy on the test fixture. The head need not be level as previously specified.
- \_\_\_14. Mark the locations AA and BB, and record the dimensions Y and Z, as specified in the table and figure 3A.

---

Signature

---

Date

## EXTERNAL DIMENSIONS

HYBRID III, PART 572, SUBPART E EXTERNAL DIMENSIONS				
DIMENSION	DESCRIPTION	DETAILS	ASSEMBLY DIMENSION (inches)	ACTUAL MEASUREMENT
A	TOTAL SITTING HEIGHT	Seat surface to highest point on top of the head.	34.6–35.0	
B	SHOULDER PIVOT HEIGHT	Centerline of shoulder pivot bolt to the seat surface.	19.9-20.5	
C	H-POINT HEIGHT	Reference	3.3-3.5	
D	H-POINT LOCATION FROM BACKLINE	Reference	5.3-5.5	
E	SHOULDER PIVOT FROM BACKLINE	Center of the shoulder clevis to the rear vertical surface of the fixture.	3.3-3.7	
F	THIGH CLEARANCE	Measured at the highest point on the upper femur segment.	5.5-6.1	
G	BACK OF ELBOW TO WRIST PIVOT	back of the elbow flesh to the wrist pivot in line with the elbow and wrist pivots	11.4-12.0	
H	HEAD BACK TO BACKLINE	Back of Skull cap skin to seat rear vertical surface (Reference)	1.6-1.8	
I	SHOULDER TO- ELBOW LENGTH	Measure from the highest point on top of the shoulder clevis to the lowest part of the flesh on the elbow in line with the elbow pivot bolt.	13.0-13.6	
J	ELBOW REST HEIGHT	Measure from the flesh below the elbow pivot bolt to the seat surface.	7.5-8.3	
K	BUTTOCK TO KNEE LENGTH	The forward most part of the knee flesh to the rear vertical surface of the fixture.	22.8-23.8	
L	POPLITEAL HEIGHT	Seat surface to the plane of the horizontal plane of the bottom of the feet.	16.9-17.9	
M	KNEE PIVOT HEIGHT	Centerline of knee pivot bolt to the horizontal plane of the bottom of the feet.	19.1-19.7	
N	BUTTOCK POPLITEAL LENGTH	The rearmost surface of the lower leg to the same point on the rear surface of the buttocks used for dim. "K".	17.8-18.8	

HYBRID III, SUBPART E EXTERIOR DIMENSIONS, continued				
DIMENSION	DESCRIPTION	DETAILS		ACTUAL MEASUREMENT
O	CHEST DEPTH WITHOUT JACKET	Measured 16.9-17.1 in. above seat surface	8.4-9.0	
P	FOOT LENGTH	Tip of toe to rear of heel	9.9-10.5	
V	SHOULDER BREADTH	Outside edges of right and left shoulder clevises	16.3-17.2	
W	FOOT BREADTH	The widest part of the foot	3.6-4.2	
Y	CHEST CIRCUMFERENCE (WITH CHEST JACKET)	Measured 16.9-17.1 in. above seat surface	38.2-39.4	
Z	WAIST CIRCUMFERENCE	Measured 8.9-9.1 in. above seat surface	32.9-34.1	
AA	REFERENCE LOCATION FOR MEASUREMENT OF CHEST CIRCUMFERENCE	Reference	16.9-17.1	
BB	REFERENCE LOCATION FOR MEASUREMENT OF WAIST CIRCUMFERENCE	Reference	8.9-9.1	

**NOTE:** THE H-POINT IS LOCATED 1.83 INCHES FORWARD AND 2.57 INCHES DOWN FROM THE CENTER OF THE PELVIS ANGLE REFERENCE HOLE.

# EXTERNAL DIMENSIONS SPECIFICATIONS

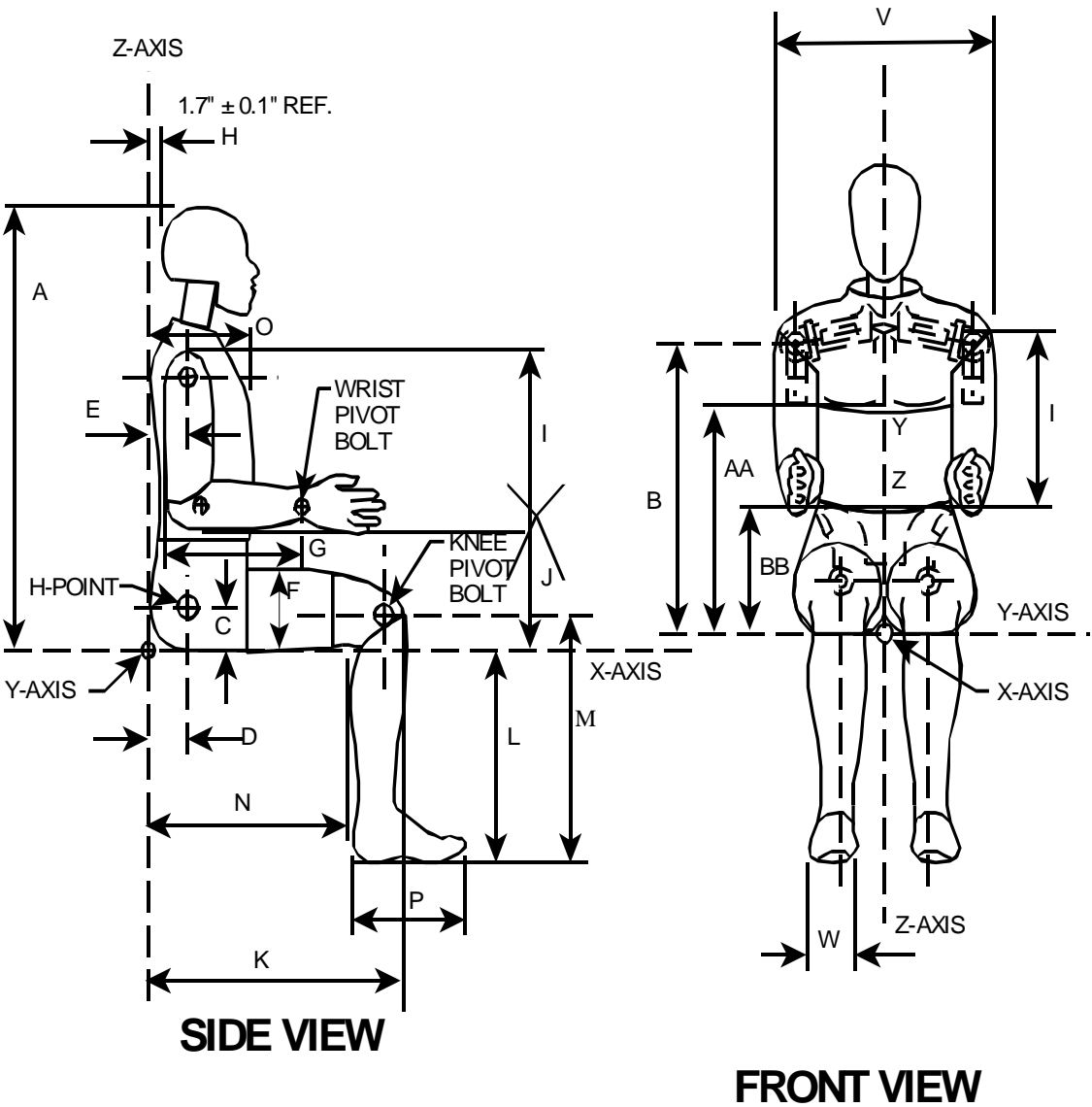

**NOTE:** Figure is referenced to the erect seated position. The curved lumbar does not allow the Hybrid III to be positioned in a perfect erect attitude. (REF: S572.31(A)(6))

# EXTERNAL DIMENSIONS TEST SETUP

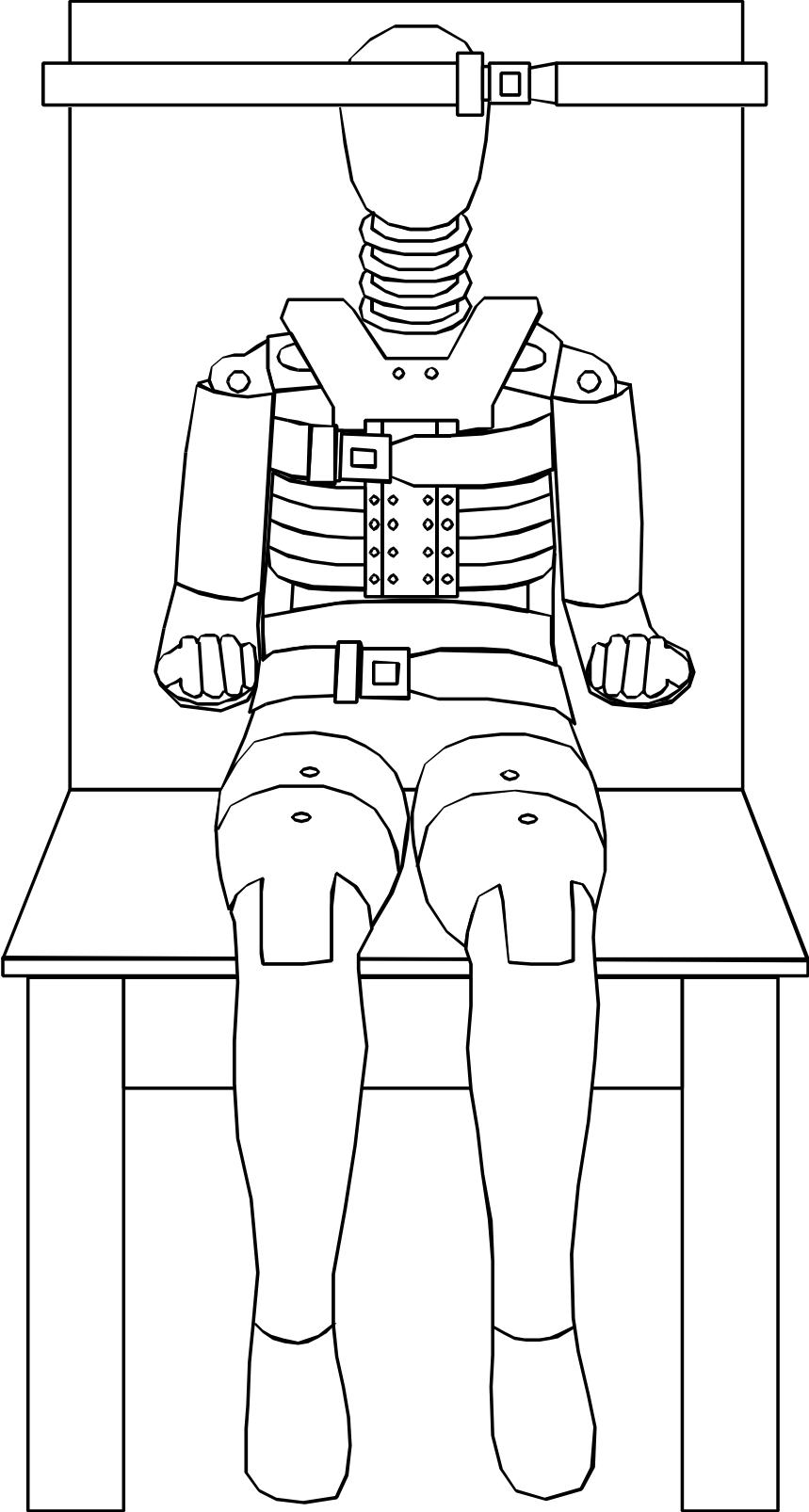

FIGURE 4A

# EXTERNAL DIMENSIONS TEST SETUP

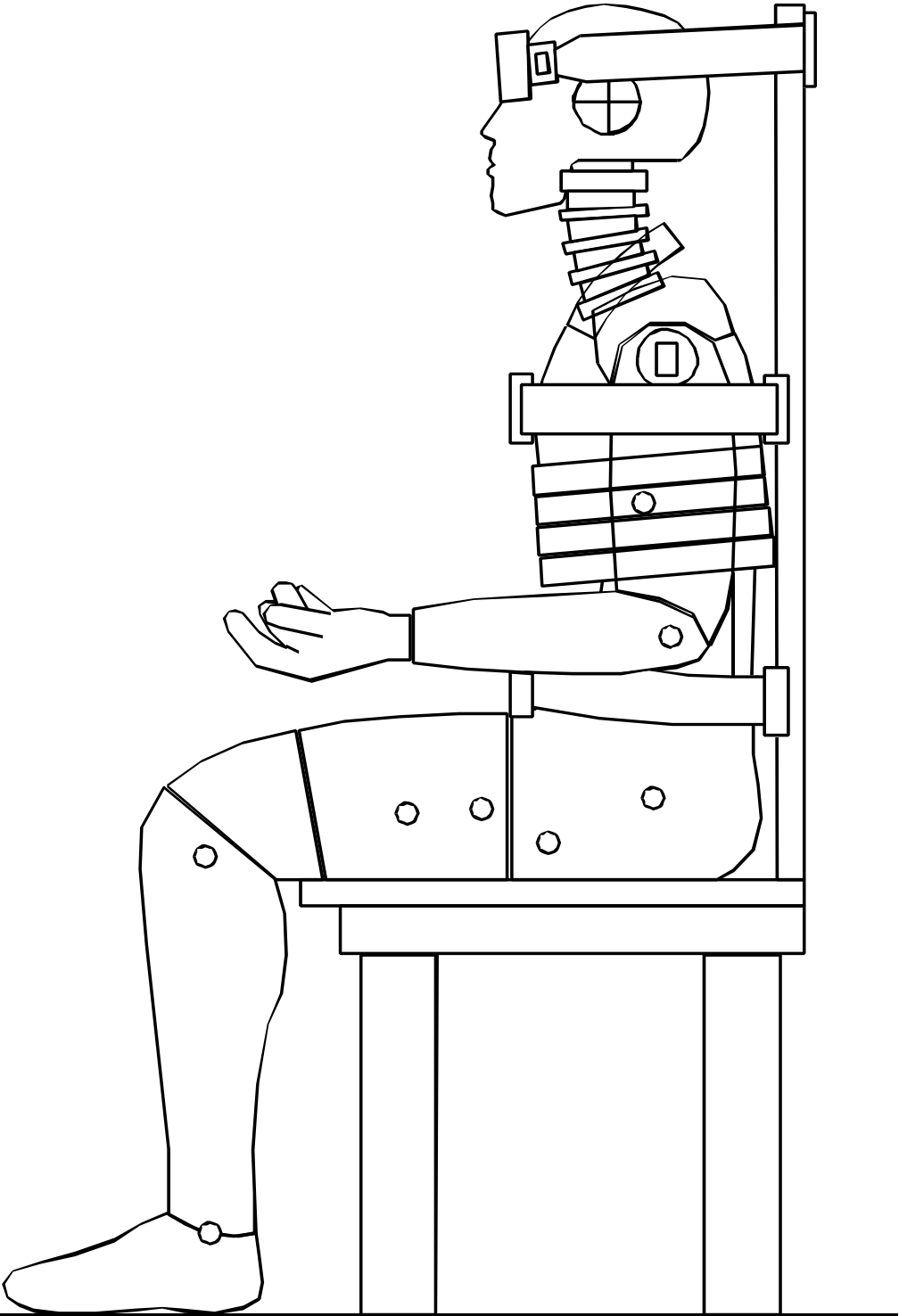

FIGURE 5A

**DATA SHEET A3**  
**HEAD DROP TEST (572.32) (50<sup>th</sup> Male)**

Dummy Serial Number \_\_\_\_\_ Test Date \_\_\_\_\_

Technician \_\_\_\_\_

- Pretest calibration
- Post test calibration verification

Test attempt no. \_\_\_\_\_ (when successive head drops are necessary)

- 1. It has been at least 3 hours since the last head drop. (572.32(c)(5))  
 N/A, ONLY one head drop performed
- 2. The head assembly consists of the complete head (78051-61X), the neck transducer structural replacement (78051-383X), and three (3) accelerometers. (572.32(b))
- 3. Torque the skull cap screws to 160 lbf-in.
- 4. Accelerometers and their respective mounts are smooth and clean.
- 6. The data acquisition system, including transducers, conforms to the requirements of SAE Recommended Practice J211/1 MAR95. (572.35(i))
- 7. The head assembly soaked at a temperature between 18.9°C (66°F) and 25.6°C (78°F) and at a relative humidity from 10% to 70% for a period of at least four (4) hours prior to a test. (572.32(c)(1))  
 Record the maximum temperature \_\_\_\_\_  
 Record the minimum temperature \_\_\_\_\_  
 Record the maximum humidity \_\_\_\_\_  
 Record the minimum humidity \_\_\_\_\_
- 8. Visually inspect the head skin for cracks, cuts, abrasions, etc. Repair or replace the head skin if the damaged area is more than superficial. Note: If the damage resulted from the vehicle crash test in which the dummy was an occupant, the damaged area is to be documented with photography and the post test calibration verification testing completed before any replacement or repairs are made.  
 Record findings and actions: \_\_\_\_\_  
 \_\_\_\_\_  
 \_\_\_\_\_  
 \_\_\_\_\_
- 9. Clean the impact surface of the skin and the impact surface of the fixture with isopropyl alcohol, 1,1,1 trichloroethane or equivalent prior to the test. (572.32(c)(2))

\_\_10. Suspend and orient the head assembly as shown in Figure 6A. The lowest point on the forehead is 0.5 in. below the lowest point on the dummy's nose when the midsagittal plane is vertical. (572.32(c)(3))

Record the actual distance \_\_\_\_\_

**NOTE:** The masses of the suspension device and the accelerometer cables are to be kept as lightweight as possible to minimize their effect on the test results.

\_\_11. The 1.6 mm (0.062 inch) diameter holes located on either side of the dummy's head are equidistance within 2 mm from the impact surface. A typical test setup is shown in Figure 7A.

Record the right side distance \_\_\_\_\_

Record the left side distance \_\_\_\_\_

\_\_12. The impact surface is clean and dry and has a micro finish in the range of  $203.2 \times 10^{-6}$  mm (8 micro inches) to  $2032.0 \times 10^{-6}$  mm (80 micro inches) (RMS). (572.32(c)(4))

Record actual micro finish \_\_\_\_\_

\_\_13. The impact surface is rigidly supported. (572.32(c)(4))

\_\_14. The impact surface is a flat horizontal steel plate 50.8 mm (2 inches) thick and 610 mm (24 inches) square. (Figure 6A)

Record thickness \_\_\_\_\_

Record width \_\_\_\_\_

Record length \_\_\_\_\_

\_\_15. Drop the head assembly from a height of  $376.0 \pm 1.0$  mm (14.8 inches  $\pm$  0.04 inches) by a means that ensures a smooth, instant release onto the impact surface. (572.32(b) & (572.32(c)(4))

\_\_16. Complete the following table using channel class 1000 data. (572.36(i)):

Parameter	Specification	Result
Peak resultant acceleration	$225 \text{ g} \leq x \leq 275 \text{ g}$	
Resultant versus time history curve	Unimodal	
Oscillations after the main pulse	Less than 10% of the peak resultant acceleration	
Lateral acceleration	y-axis acceleration $\leq 15 \text{ g}$	

\_\_17. Plots of the x, y, z, and resultant acceleration data follow this sheet.

\_\_\_\_\_  
Signature

\_\_\_\_\_  
Date

**TEST SET-UP SPECIFICATIONS**

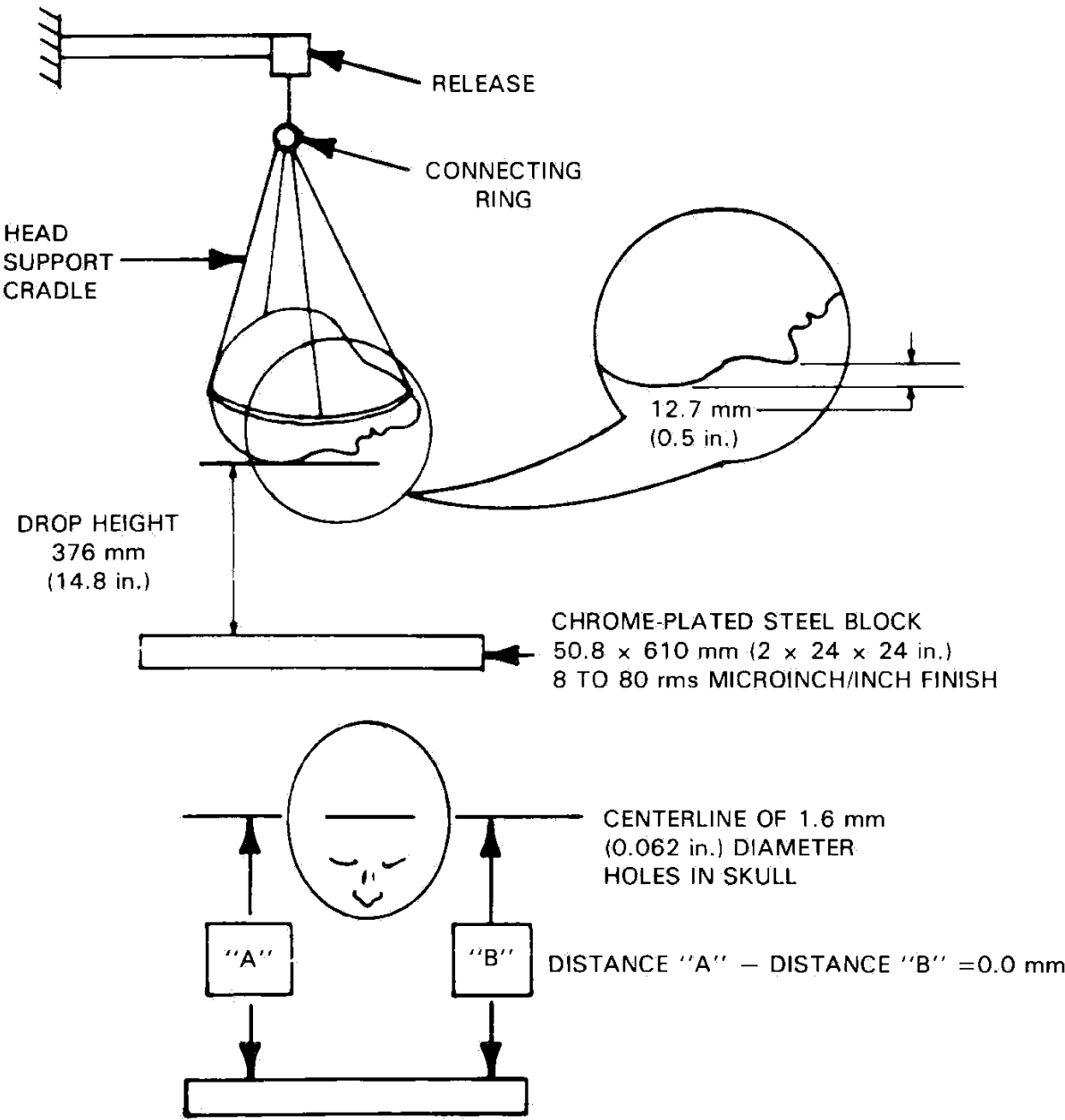

NOTE: TOLERANCE ON TEST SETUP DIMENSIONS  $\pm 1$  mm (0.04 in.)

FIGURE 6A

# HEAD DROP TEST SETUP

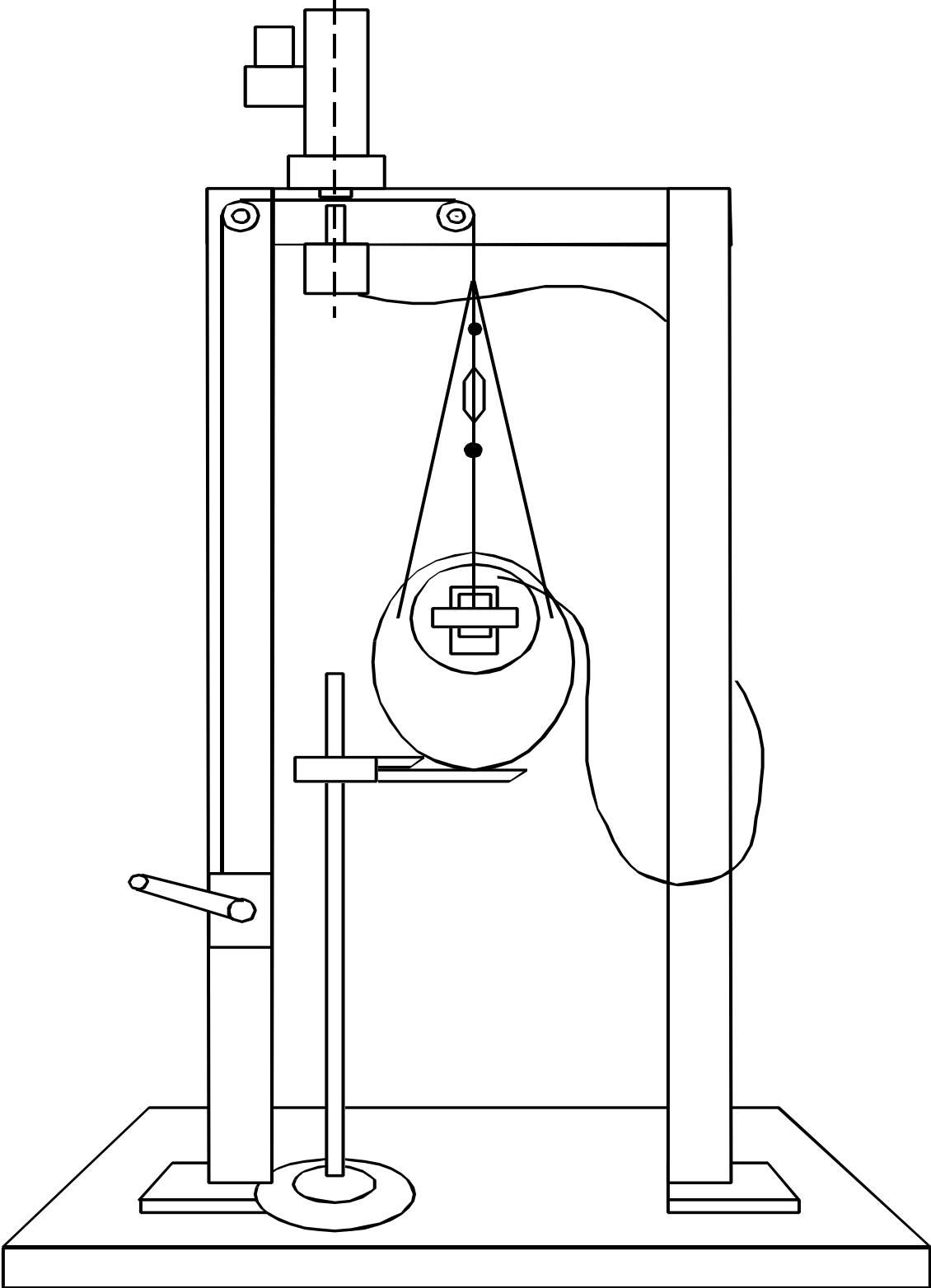

FIGURE 7A

DATA SHEET A4

**DATA SHEET A4**  
**NECK FLEXION TEST (572.33) (50<sup>th</sup> Male)**

Dummy Serial Number \_\_\_\_\_ Test Date \_\_\_\_\_

Technician \_\_\_\_\_

- Pretest calibration
- Post test calibration verification

Test attempt no. \_\_\_\_\_ (when successive flexion tests are necessary)

- 1. It has been at least 30 minutes since the last flexion test. (572.36(m))  
 N/A, ONLY one neck test performed
- 2. The components required for the neck tests include the head assembly (78051-61X), neck assembly (78051-90), bib simulator (78051-84), upper neck adjusting bracket (78051-307), lower neck adjusting bracket (78051-303), six axis neck transducer (C-1709) and either three accelerometers or their mass equivalent installed in the head assembly. Data from the accelerometers are not required. (572.33(b))
- 3. The assembly soaked at a temperature between 20.6°C (69°F) and 22.2°C (72°F) and at a relative humidity from 10% to 70% for a period of at least four (4) hours prior to a test. (572.33(c)(1))  
 Record the maximum temperature \_\_\_\_\_  
 Record the minimum temperature \_\_\_\_\_  
 Record the maximum humidity \_\_\_\_\_  
 Record the minimum humidity \_\_\_\_\_
- 4. Visually inspect neck assembly for cracks, cuts and separation of the rubber from the metal segments. Note: If the damage resulted from the vehicle crash test in which the dummy was an occupant, the damaged area is to be documented with photography and the post test calibration verification testing completed before any replacement or repairs are made.  
 Record findings and actions: \_\_\_\_\_  
 \_\_\_\_\_  
 \_\_\_\_\_  
 \_\_\_\_\_
- 5. Inspect the nodding blocks (78051-351) for any deterioration, but when replacement is necessary, ONLY replace during pre-test calibration. Using a Shore "A" type Durometer, verify the hardness of the nodding blocks is between 80 and 90. Ensure the nodding blocks are installed correctly. (78051-90).  
 Record findings and actions: \_\_\_\_\_  
 \_\_\_\_\_  
 \_\_\_\_\_  
 \_\_\_\_\_

- \_\_6. Pre-test calibration Neck cable torque: Torque the jam nut (78051-64) on the neck cable (78051-301) to  $1.0 \pm 0.2$  lb-ft by loosening the jam nut and relaxing the neck cable before torquing. (572.33(c)(2))
- \_\_7. The data acquisition system, including transducers, conforms to the requirements of SAE Recommended Practice J211/1 MAR95. (572.36(i))
- \_\_8. The test fixture pendulum conforms to the specifications in Figure 8A. (572.33(c)(3))
- \_\_9. The head-neck assembly is mounted on the pendulum so the midsagittal plane of the head is vertical and coincides with the plane of motion of the pendulum longitudinal centerline as shown in Figure 9A for the flexion test. (572.33(c)(3))
- \_\_10. Install the transducers or other devices for measuring the "D" plane rotation with respect to the pendulum longitudinal centerline. Note: Plane "D" is the bottom horizontal surface of the skull. These measurement devices should be designed to minimize their influence upon the performance of the head-neck assembly. An example of a measurement device is shown in Figure 11A.
- \_\_11. With the pendulum resting against the honeycomb material, the neck bracket was adjusted until the longitudinal centerline of the pendulum was perpendicular  $\pm 1$  degree to plane "D" on the dummy's head.
- \_\_12. Release the pendulum and allow it to fall freely from a height to achieve an impact speed of 22.6 to 23.4 ft/sec as measured at the center of the pendulum accelerometer. (572.33(c)(4))

\_\_13. Complete the following table:

Neck Flexion Test Results (572.33(b)(1) & (572.33(c)(4))

Parameter	Specification	Result
Pendulum impact speed	22.6 ft/sec ≤ speed ≤ 23.4 ft/sec	
Pendulum Deceleration Versus Time Pulse	@ 10ms	22.5 ≤ g ≤ 27.5
	@ 20 ms	17.6 ≤ g ≤ 22.6
	@30ms	12.5 ≤ g ≤ 18.5
	Above 30 ms	29 g maximum
First Pendulum Decay to 5g	34 ms ≤ time ≤ 42 ms	
Plane D Rotation	64° ≤ max. rotation ≤ 78°	
	57 ms ≤ time of max. rotation ≤ 64 ms	
Time for Plane D Rotation to Cross 0° During First Rebound	113 ms ≤ time ≤ 128 ms	
Maximum Moment	65 lbf-ft ≤ moment ≤ 80 lbf-ft	
	47 ms ≤ time of max. moment ≤ 58 ms	
Time of first decay to 0 lbf-ft Positive Moment Decay** (Flexion)	97 ms ≤ time ≤ 107ms	

\*Moment about the occipital condyle =  $M_y - (0.058 \text{ ft} \times F_x)$  (572.33(b)(1)(ii))

$M_y$  = Moment in lbf-ft measured by the transducer

$F_x$  = Force, in lbf measured by the transducer

\*\*Time zero is defined as the time of initial contact between the pendulum striker plate and the honeycomb material. (572.133(b)(3))

\_\_14. Plots of pendulum acceleration, y-axis moment, x-axis force, y-axis moment about the occipital condyle, and D plane rotation follows this sheet.

\_\_\_\_\_  
Signature

\_\_\_\_\_  
Date

**DATA SHEET A5**  
**NECK EXTENSION TEST (572.33) (50<sup>th</sup> Male)**

Dummy Serial Number \_\_\_\_\_ Test Date \_\_\_\_\_

Technician \_\_\_\_\_

- Pretest calibration
- Post test calibration verification

Test attempt no. \_\_\_\_\_ (when successive extension tests are necessary)

- 1. It has been at least 30 minutes since the last extension test. (572.36(m))  
 N/A, ONLY one neck test performed
- 2. The components required for the neck tests include the head assembly (880105-100X), neck (880105-250), bib simulator (880105-371), upper neck adjusting bracket (880105-207), lower neck adjusting bracket (880105-208), six axis neck transducer (SA572-S11) and either three accelerometers (SA572-S4) or their mass equivalent installed in the head assembly as specified in drawing 880105-100X. Data from the accelerometers are not required. (572.33(b))
- 3. The assembly soaked at a temperature between 20.6°C (69°F) and 22.2°C (72°F) and at a relative humidity from 10% to 70% for a period of at least four (4) hours prior to a test. (572.33(c)(1))  
 Record the maximum temperature \_\_\_\_\_  
 Record the minimum temperature \_\_\_\_\_  
 Record the maximum humidity \_\_\_\_\_  
 Record the minimum humidity \_\_\_\_\_
- 4. Visually inspect neck assembly for cracks, cuts and separation of the rubber from the metal segments. Note: If the damage resulted from the vehicle crash test in which the dummy was an occupant, the damaged area is to be documented with photography and the post test calibration verification testing completed before any replacement or repairs are made.  
 Record findings and actions: \_\_\_\_\_  
 \_\_\_\_\_  
 \_\_\_\_\_  
 \_\_\_\_\_
- 5. Inspect the nodding blocks (78051-351) for any deterioration, but when replacement is necessary, ONLY replace during pre-test calibration. Using a Shore "A" type Durometer, verify the hardness of the nodding blocks is between 80 and 90. Ensure the nodding blocks are installed correctly. (880105-250 and PADI page17).  
 Record findings and actions: \_\_\_\_\_  
 \_\_\_\_\_  
 \_\_\_\_\_

- \_\_\_6. Pre-test calibration Neck cable torque: Torque the jam nut (78051-64) on the neck cable (78051-301) to  $1.0 \pm 0.2$  lb-ft by loosening the jam nut and relaxing the neck cable before torquing. (572.33(c)(2))
- \_\_\_7. The data acquisition system, including transducers, conforms to the requirements of SAE Recommended Practice J211/1 MAR95. (572.36(i))
- \_\_\_8. The test fixture pendulum conforms to the specifications in Figure 8A. (572.33(c)(3))
- \_\_\_9. The head-neck assembly is mounted on the pendulum so the midsagittal plane of the head is vertical and coincides with the plane of motion of the pendulum longitudinal centerline as shown in Figure 10A for the extension test. (572.33(c)(3))
- \_\_\_10. Install the transducers or other devices for measuring the "D" plane rotation with respect to the pendulum longitudinal centerline. Note: Plane "D" is the bottom horizontal surface of the skull. These measurement devices should be designed to minimize their influence upon the performance of the head-neck assembly. An example of a measurement device is shown in Figure 11A.
- \_\_\_11. With the pendulum resting against the honeycomb material, the neck bracket was adjusted until the longitudinal centerline of the pendulum was perpendicular  $\pm 1$  degree to plane "D" on the dummy's head.
- \_\_\_12. Release the pendulum and allow it to fall freely from a height to achieve an impact speed of 19.5 ft/s to 20.3 ft/s as measured at the center of the pendulum accelerometer. (572.33(c)(4))

\_\_13. Complete the following table:

Neck Extension Test Results (572.33(b)(2) & (572.33(c)(4))

Parameter	Specification	Result
Pendulum impact speed	19.5 ft/sec ≤ speed ≤ 20.3 ft/sec	
Pendulum Deceleration versus time pulse	@ 10ms	17.2 ≤ g ≤ 21.2
	@ 20 ms	14 ≤ g ≤ 19
	@30ms	11.0 ≤ g ≤ 16.0
	Above 30 ms	22 g maximum
First Pendulum Decay to 5g	38 ms ≤ time ≤ 46 ms	
Plane D Rotation	81° ≤ max. rotation ≤ 106°	
	72 ms ≤ time of max. rotation ≤ 82 ms	
Time for Plane D Rotation to Cross 0° During First Rebound	147 ms ≤ time ≤ 174 ms	
Maximum Moment	-59 lbf-ft ≤ moment ≤ -39 lbf-ft	
	65 ms ≤ time ≤ 79 ms	
Time of first decay to 0 lbf-ft Negative Moment Decay** (Extension)	120 ms ≤ time ≤ 148 ms	

\*Moment about the occipital condyle =  $M_y - (0.01778 \text{ m} \times F_x)$  (572.133(b)(1)(ii))

$M_y$  = Moment in Nm measured by the transducer

$F_x$  = Force, in N measured by the transducer

\*\*Time zero is defined as the time of initial contact between the pendulum striker plate and the honeycomb material. (572.133(b)(3))

\_\_14. Plots of pendulum acceleration, y-axis moment, x-axis force, y-axis moment about the occipital condyle, and D plane rotation follows this sheet.

\_\_\_\_\_  
Signature

\_\_\_\_\_  
Date

**PENDULUM SPECIFICATIONS**

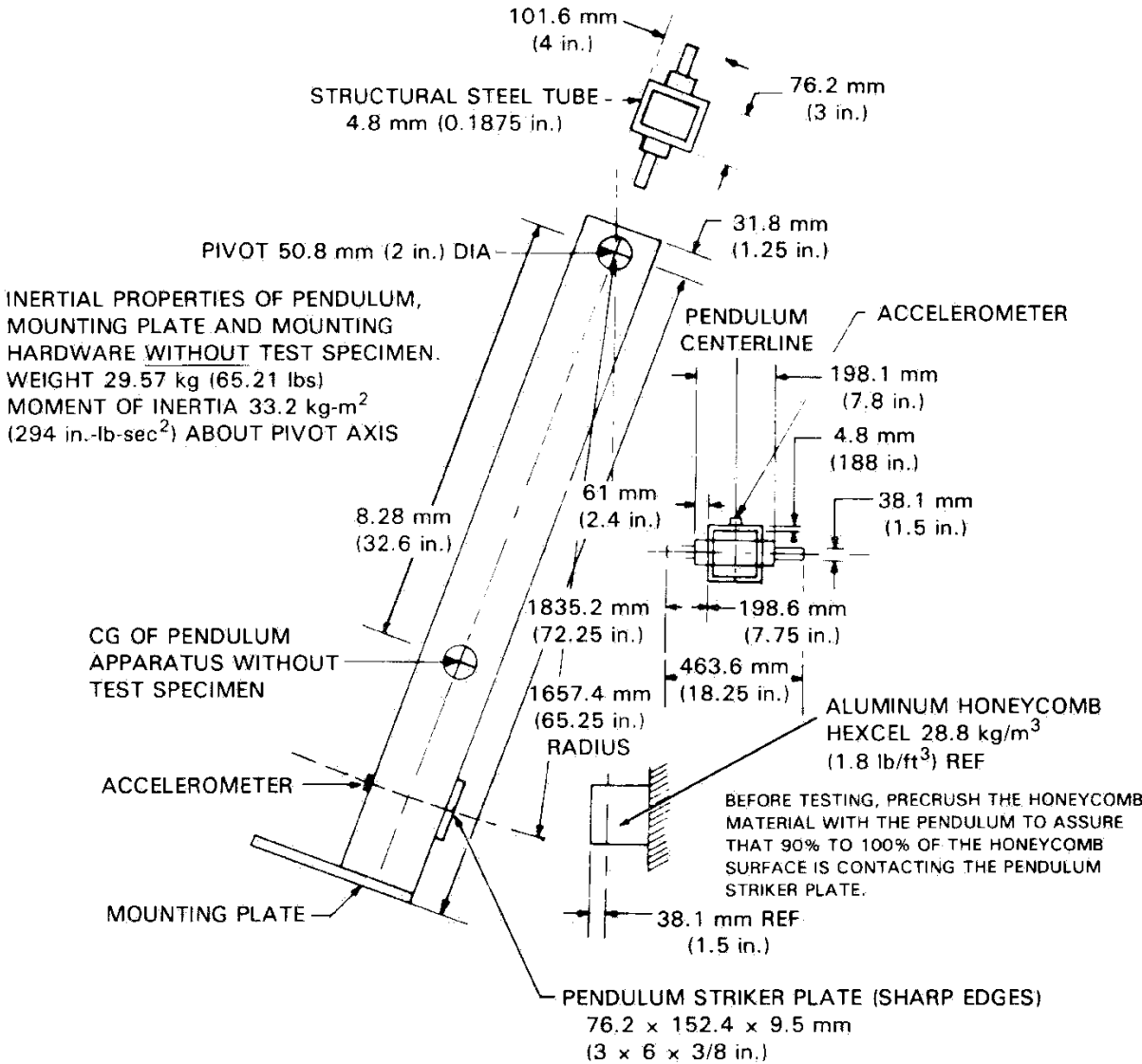

**FIGURE 8A**

# FLEXION - TEST SET-UP SPECIFICATIONS

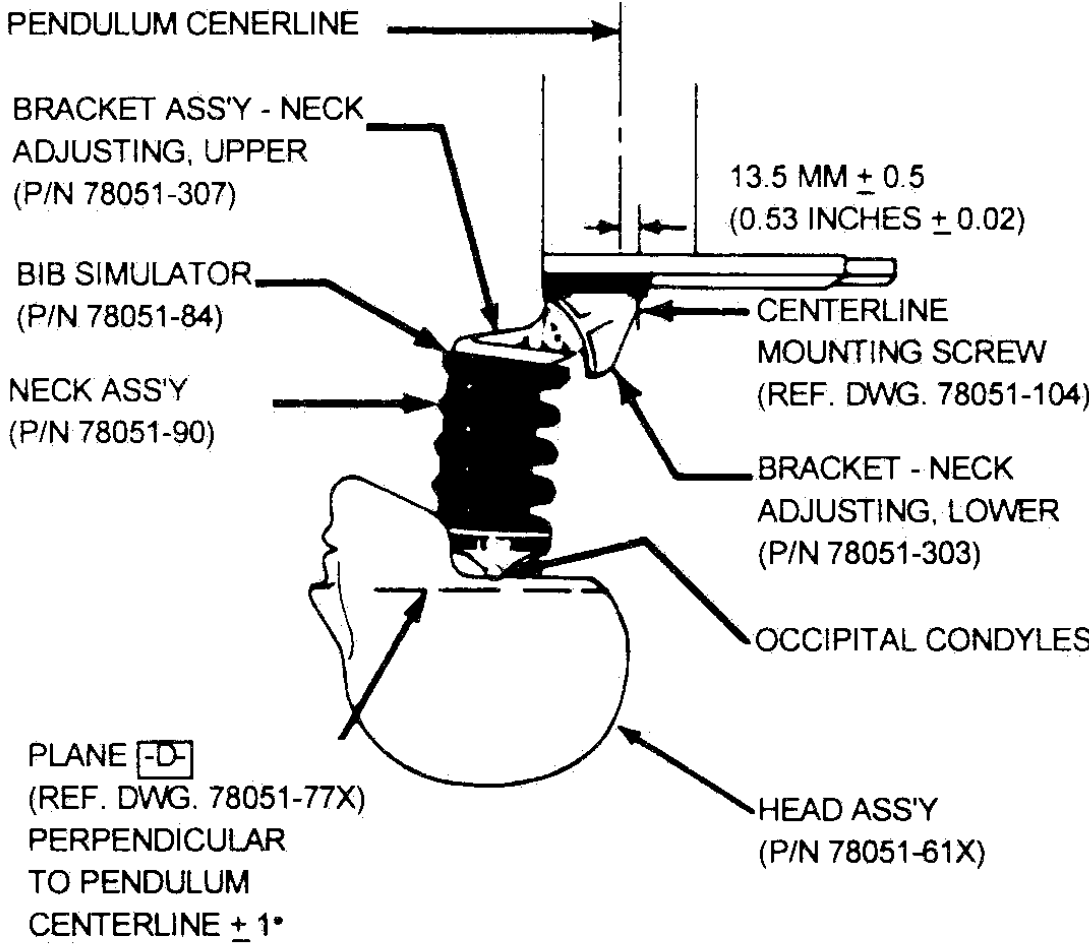

NOTE: PENDULUM SHOWN AT TIME ZERO POSITION

FIGURE 9A

# EXTENSION - TEST SET-UP SPECIFICATIONS

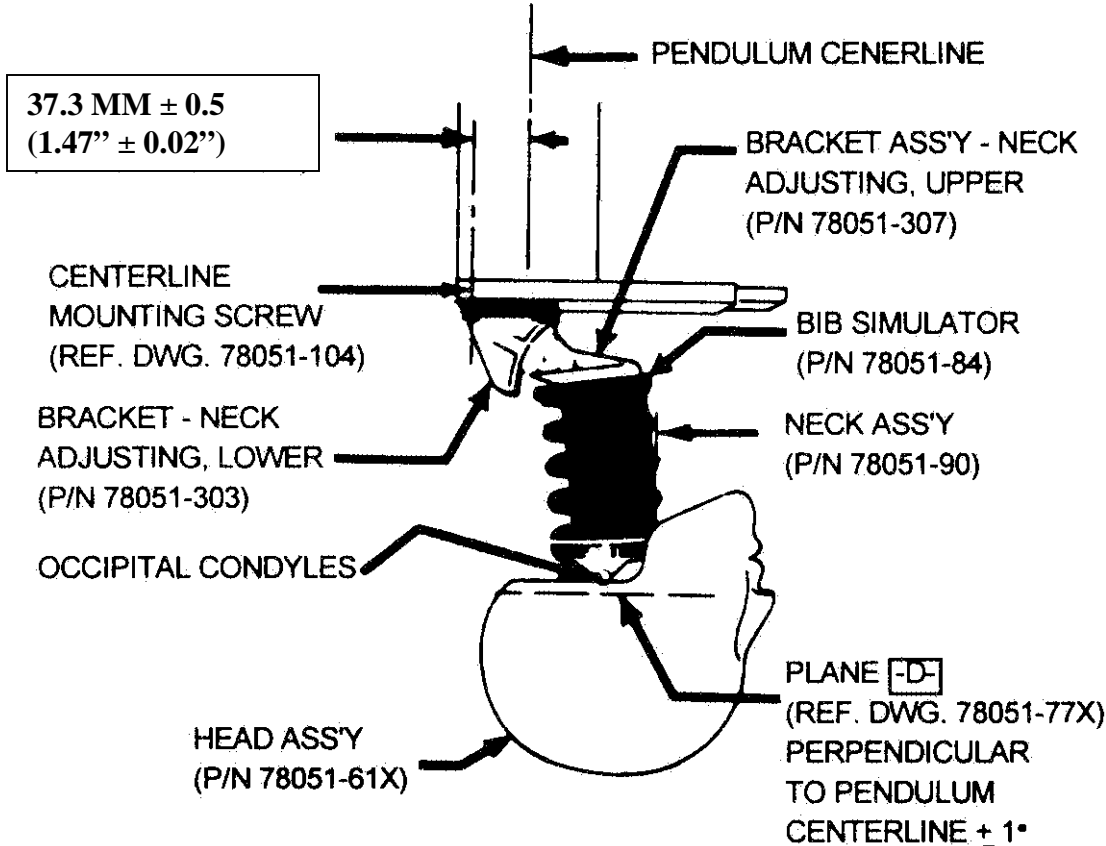

NOTE: PENDULUM SHOWN AT TIME ZERO POSITION

FIGURE 10A

# ROTATION TRANSDUCER ASSEMBLY

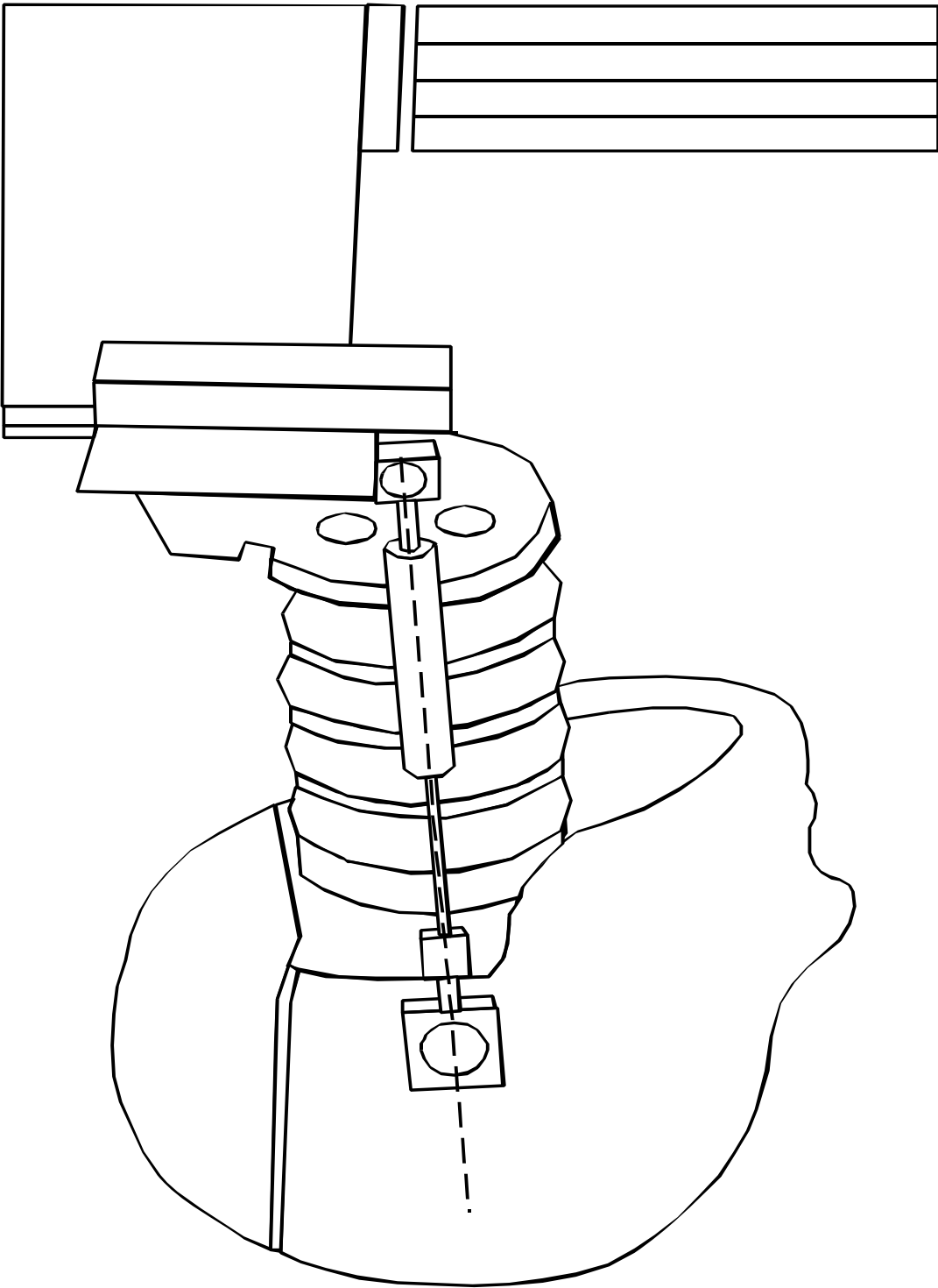

**FIGURE 11A**

**DATA SHEET A6**  
**THORAX IMPACT TEST (572.34) (50<sup>th</sup> Male)**

Dummy Serial Number \_\_\_\_\_ Test Date \_\_\_\_\_

Technician \_\_\_\_\_

- Pretest calibration
- Post test calibration verification

Test attempt no. \_\_\_\_ (when successive thorax impact tests are necessary)

- 1. It has been at least 30 minutes since the last thorax impact test. (572.137(q))  
 N/A, ONLY one thorax impact test performed
- 2. The test fixture conforms to the specifications in Figure 12A.
- 3. The complete assembled dummy (78051-218) is used (572.34(b)) and is dressed in a form fitting cotton stretch above-the-elbow sleeved shirt and above-the-knee pants. No shoes are worn. (572.34(b))
- 4. The dummy assembly soaked at a temperature between 20.6°C (69°F) and 22.2°C (72°F) and at a relative humidity from 10% to 70% for a period of at least four (4) hours prior to this test. (572.34(c)(1))  
 Record the maximum temperature \_\_\_\_\_  
 Record the minimum temperature \_\_\_\_\_  
 Record the maximum humidity \_\_\_\_\_  
 Record the minimum humidity \_\_\_\_\_
- 5. Remove the chest skin and visually inspect the thorax assembly for cracks, cuts, abrasions, etc. Particular attention should be given to the rib damping material (78051-17 thru 78051-22), chest displacement transducer assembly (78051-317) and the rear rib supports (78051-304). Inspect for rib deformation using the chest depth gage (83-5006-007). If any damage is noted repair and/or replace the damaged components unless the damage resulted from the vehicle crash test in which the dummy was an occupant in which case the damage must be documented and post test calibration verification testing completed before any repairs or replacements are made.  
 - No damage  
 - Damage from crash test, no repairs or replacement because this is a post test calibration verification. Record damage \_\_\_\_\_  
 \_\_\_\_\_  
 - The following repairs or replacement was performed. Record  
 \_\_\_\_\_  
 \_\_\_\_\_
- 6. Seat the dummy, (chest skin still removed) without back and arm supports on the test fixture surface as shown in Figure 12A. The surface must be long enough to support the pelvis and outstretched legs. (572. 34(c)(2))
- 7. Level the ribs both longitudinally and laterally  $\pm 0.5^\circ$  and adjust the pelvis angle to  $13^\circ \pm 2^\circ$ . The angle may be measured using the special H-point tool (78051-532)

- that inserts into the pelvic structure and extends outward beyond the pelvic skin surface or by using the surface of the pelvic adaptor block. (572.34(c)(2))
- \_\_8. The midsagittal plane of the dummy is vertical within  $\pm 1^\circ$ . (572.134(c)(3))
  - \_\_9. The longitudinal centerline of the test probe is centered within  $\pm 2.5$  mm of the midsagittal plane of the dummy and is  $12.7 \text{ mm} \pm 1 \text{ mm}$  below the horizontal peripheral centerline of the No. 3 rib and is within  $0.5^\circ$  of a horizontal line in the dummy's midsagittal plane. (572.34(c)(4))
  - \_\_10. Align the adjustable neck bracket index marks to the "zero" position. (Figure 12A)
  - \_\_11. Record locations such as the rear surfaces of the thoracic spine and the lower neck bracket reference with respect to locations such as the rear surfaces of the thoracic spine and the lower neck bracket. These reference measurements are necessary to ensure the dummy is in the same position after the chest skin is installed. The reference locations must be accessible after installation of the chest skin. It may be necessary to leave the chest skin zipper unfastened until the references are checked and fasten it just prior to the test.
  - \_\_12. Install the chest skin and reposition the dummy as described in the preceding paragraph using the reference measurements recorded.
  - \_\_13. Place the arm assemblies horizontal  $\pm 2^\circ$  and parallel to the midsagittal plane. The arms are held in place by tightening the adjustment nut that holds the arm yoke to the clavicle assembly.
  - \_\_14. The data acquisition system, including transducers, must conform to the requirements of SAE Recommended Practice J211/1 MAR95 Class 180.
  - \_\_15. Impact the anterior surface of the thorax with the test probe so the longitudinal centerline of the probe is within  $2^\circ$  of a horizontal line in the dummy's midsagittal plane at the moment of impact. (572.34(c)(5)) The velocity of the test probe at the time of impact is  $22 \text{ f/s} \pm 0.4 \text{ f/s}$ . (572.34(b)) The probe is guided so there is no significant lateral, vertical or rotational movement during the impact. (572.34(c)(6))

\_\_16. Complete the following table:

Thorax Impact Results (572.34(b))

Parameter*	Specification	Result
Test Probe Speed	21.6 f/s ≤ speed ≤ 22.4 f/s	
Chest Compression	2.5 in. ≤ compression ≤ 2.86 in.	
Peak resistance force**	1160 lb ≤ peak force ≤ 1325 lb	
Internal Hysteresis***	69% ≤ hysteresis ≤ 85%	

\*Time zero is defined as the time of initial contact between the test probe and the chest skin.

\*\*Force = impactor mass x acceleration (572.34(b))

\*\*\*Area under loading curve minus the area under the unloading curve divided by the area under the loading curve.

\_\_17. Plots of chest compression, pendulum acceleration, pendulum speed, and force, follow this sheet.

\_\_\_\_\_  
Signature

\_\_\_\_\_  
Date

**TEST SET-UP SPECIFICATIONS**

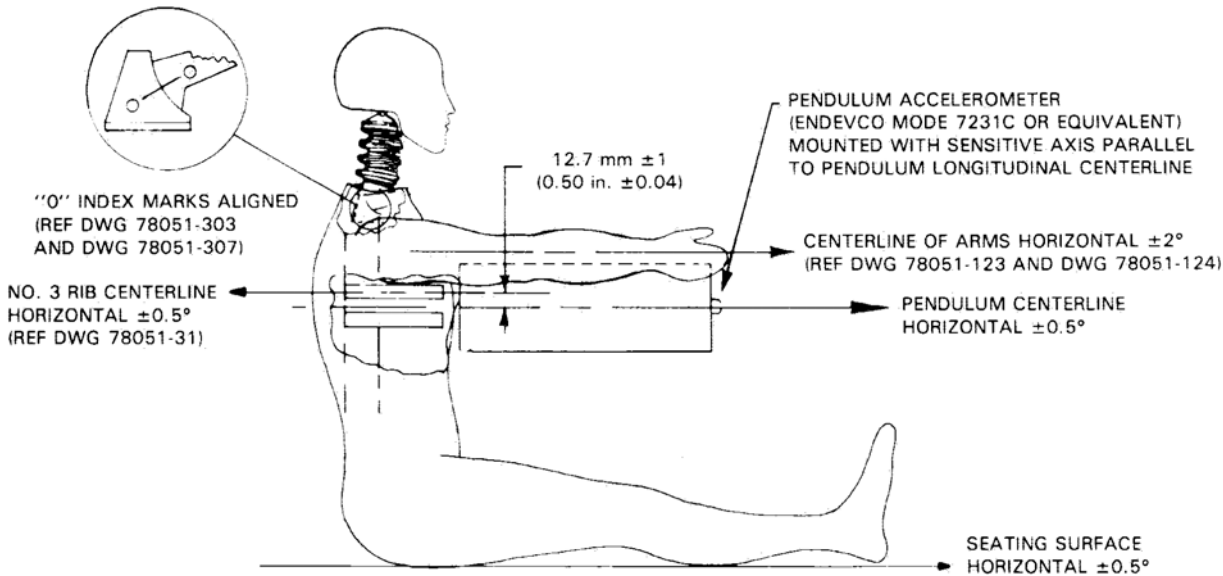

NOTE: A) NO EXTERNAL SUPPORT IS REQUIRED ON THE DUMMY TO MEET SETUP SPECIFICATIONS

B) THE MIDSAGITTAL PLANE OF THE DUMMY IS VERTICAL ( $\pm 1^\circ$ ) AND WITHIN  $2^\circ$  OF THE CENTERLINE OF THE PENDULUM

C) THE MIDSAGITTAL PLANE OF THE DUMMY IS CENTERED ON THE CENTERLINE OF THE PENDULUM WITHIN 3 mm (0.12 in.)

**FIGURE 12A**

PART 572E HYBRID III THORAX CALIBRATION - HYSTERESIS

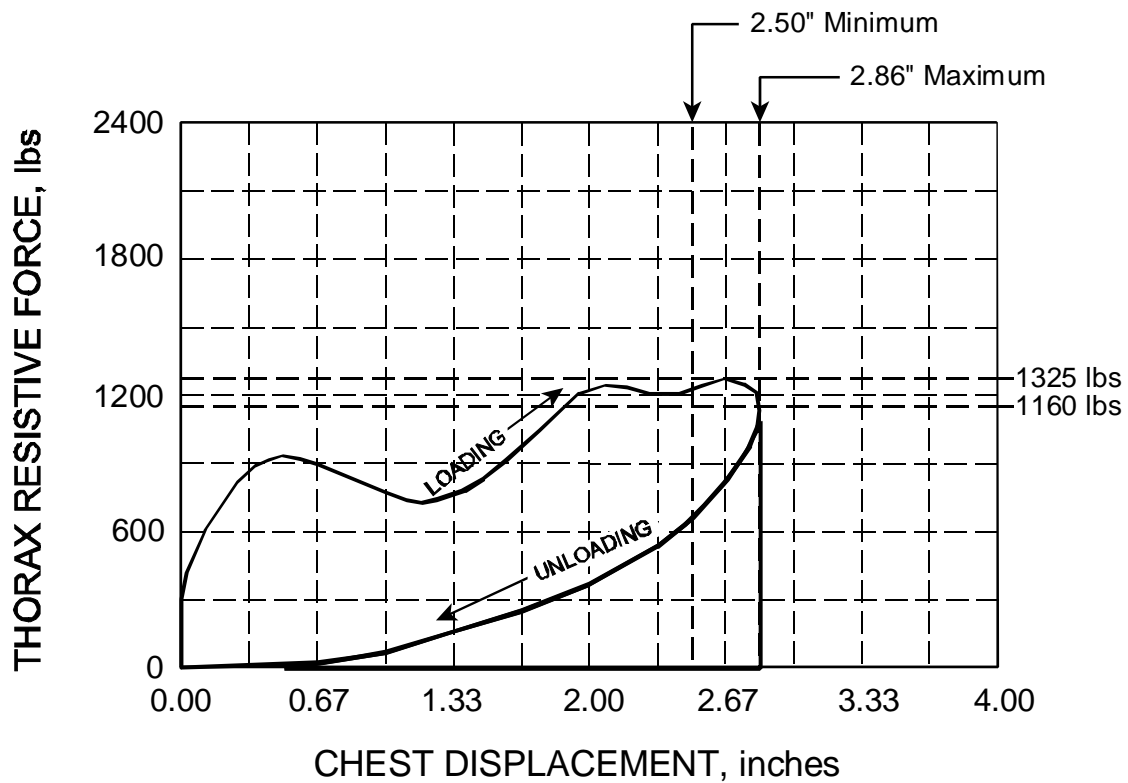

FIGURE 13A

**DATA SHEET A7**  
LEFT KNEE IMPACT TEST (572.35) (50<sup>th</sup> Male)

Dummy Serial Number \_\_\_\_\_ Test Date \_\_\_\_\_

Technician \_\_\_\_\_

- Pretest calibration
- Post test calibration verification

Test attempt no. \_\_\_\_\_ (when successive knee impact tests are necessary)

- 1. It has been at least 30 minutes since the last knee impact test. (572.36(m))  
 N/A, ONLY one knee impact test performed
- 2. The test fixture conforms to the specifications in Figure 14A.
- 3. The leg assembly (86-5001-001) with the upper leg assembly (78051-46) removed, and the load cell simulator (78051-319) is used. (572.35(b)(2))
- 4. The knee assembly soaked at a temperature between 18.9°C (66°F) and 25.6°C (78°F) and at a relative humidity from 10% to 70% for a period of at least four (4) hours prior to this test. (572.35(b)(2)(ii))  
 Record the maximum temperature \_\_\_\_\_  
 Record the minimum temperature \_\_\_\_\_  
 Record the maximum humidity \_\_\_\_\_  
 Record the minimum humidity \_\_\_\_\_
- 5. Mount the test specimen and secure it to the rigid test fixture. (572.35(b)(2)(iii)) (Figure 14A)
- 6. No parts of the foot or tibia contact any exterior surface. (572.35(b)(2)(iii))
- 7. Align the test probe so that at contact the longitudinal centerline of the probe is collinear within 2 degrees with the longitudinal centerline of the femur load cell simulator except it is within 0.5 degrees horizontally. (572.35(b)(2)(iv)&(vi))
- 8. The probe is guided so there is no significant lateral, vertical or rotational movement during the impact with the knee. (572.35(b)(2)(v))
- 9. The data acquisition system, including transducers, must conform to the requirements of SAE Recommended Practice J211/1 MAR95 (572.136(m)) Class 600.
- 10. Contact the knee with the test probe at a speed between 6.8 ft/s and 7.0 ft/s. (572.35(b))
- 11. Complete the following table:

Knee Impact Results (572.35(b)(1))

Parameter	Specification	Result
Probe speed	6.8 ft/s ≤ speed ≤ 7.0 ft/s	
Peak resistance force*	1060 lb ≤ force ≤ 1300 lb	

\*Force = impactor mass x deceleration (572.35(b)(1))

- \_\_12. Plots of pendulum acceleration, pendulum speed, and force, follow this sheet.  
Time zero is defined as the time of contact between the test probe and the knee.  
(572.3(b)(2)(vii))

---

Signature

---

Date

**DATA SHEET A8**  
**RIGHT KNEE IMPACT TEST (572.35) (50<sup>th</sup> Male)**

Dummy Serial Number \_\_\_\_\_ Test Date \_\_\_\_\_

Technician \_\_\_\_\_

Pretest calibration

Post test calibration verification

Test attempt no. \_\_\_\_\_ (when successive knee impact tests are necessary)

1. It has been at least 30 minutes since the last knee impact test. (572.36(m))  
 N/A, ONLY one knee impact test performed
2. The test fixture conforms to the specifications in Figure 14A.
3. The leg assembly (86-5001-002) with the upper leg assembly (78051-47) removed, and the load cell simulator (78051-319) is used. (572.35(b)(2))
4. The knee assembly soaked at a temperature between 18.9°C (66°F) and 25.6°C (78°F) and at a relative humidity from 10% to 70% for a period of at least four (4) hours prior to this test. (572.35(b)(2)(ii))  
 Record the maximum temperature \_\_\_\_\_  
 Record the minimum temperature \_\_\_\_\_  
 Record the maximum humidity \_\_\_\_\_  
 Record the minimum humidity \_\_\_\_\_
5. Mount the test specimen and secure it to the rigid test fixture. (572.35(b)(2)(iii)) (Figure 14A)
6. No parts of the foot or tibia contact any exterior surface. (572.35(b)(2)(iii))
7. Align the test probe so that at contact the longitudinal centerline of the probe is collinear within 2 degrees with the longitudinal centerline of the femur load cell simulator except it is within 0.5 degrees horizontally. (572.35(b)(2)(iv)&(vi))
8. The probe is guided so there is no significant lateral, vertical or rotational movement during the impact with the knee. (572.35(b)(2)(v))
9. The data acquisition system, including transducers, must conform to the requirements of SAE Recommended Practice J211/1 MAR95 (572.136(m)) Class 600.
10. Contact the knee with the test probe at a speed between 6.8 ft/s and 7.0 ft/s. (572.35(b))
11. Complete the following table:

Knee Impact Results (572.35(b)(1))

Parameter	Specification	Result
Probe speed	6.8 ft/s ≤ speed ≤ 7.0 ft/s	
Peak resistance force*	1060 lb ≤ force ≤ 1300 lb	

\*Force = impactor mass x deceleration (572.35(b)(1))

- \_\_12. Plots of pendulum acceleration, pendulum speed, and force, follow this sheet.  
Time zero is defined as the time of contact between the test probe and the knee.  
(572.3(b)(2)(vii))

---

Signature

---

Date

**TEST SET-UP SPECIFICATIONS**

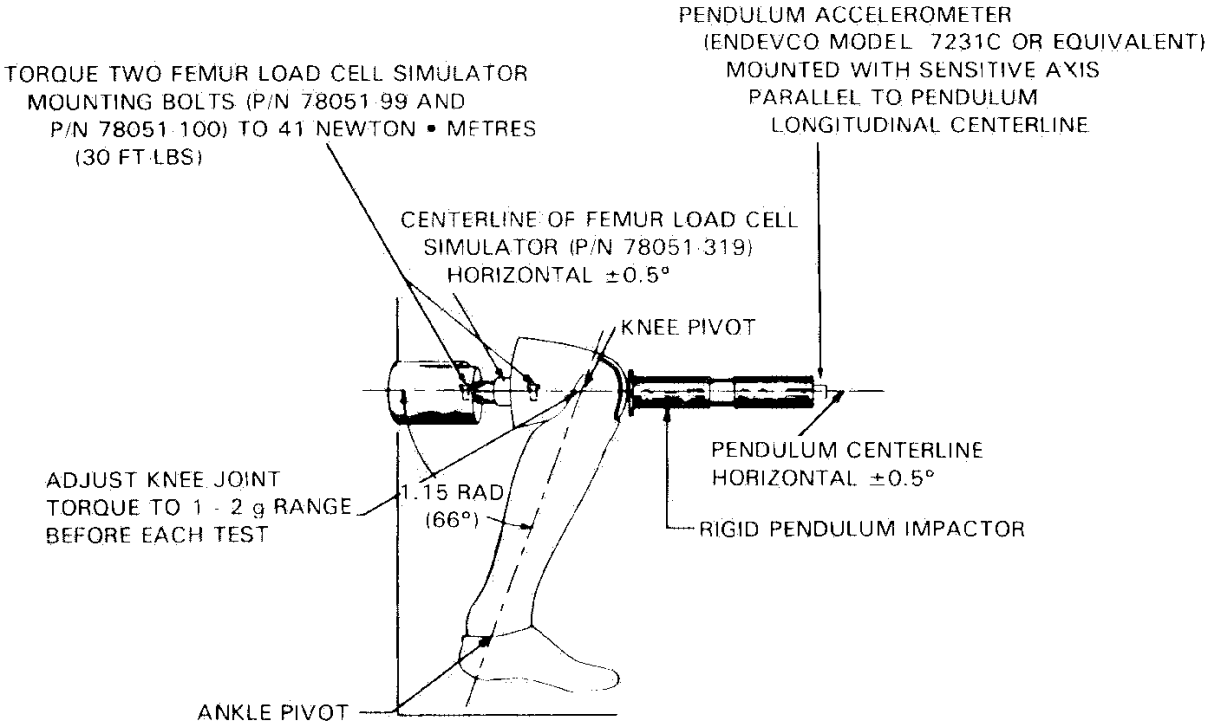

**FIGURE14A**

**DATA SHEET A9**  
**HIP JOINT-FEMUR FLEXION (572.35(c)) (50<sup>th</sup> Male)**

Dummy Serial Number \_\_\_\_\_ Test Date \_\_\_\_\_

Technician \_\_\_\_\_

Pretest calibration

Post test calibration verification

Test attempt no. \_\_\_\_ (when successive hip joint-femur flexion tests are necessary)

1. It has been at least 30 minutes since the last hip joint-femur flexion test. (572.36(m))  
 N/A, ONLY one hip joint-femur flexion test performed
2. The test fixture conforms to the specifications in Figure 17A.
3. Use the assembled dummy (78051-218) except (572.35(c)(2)):  
 3.1 remove the leg assemblies (86-5001-001 & 002) by removing 3/8-16 Socket Head Cap Screw and retaining the structural assembly of the upper legs (78051-43 & 44)  
 3.2 remove the abdominal insert (78051-52)  
 3.3 replace the instrument cover plate (78051-13) in the pelvic bone with a rigid pelvic bone stabilizer insert (Figure 15A) and attach the pelvis upper support device (Figure 16A).
4. The assembly soaked at a temperature between 18.9°C (66°F) and 25.6°C (78°F) and at a relative humidity from 10% to 70% for a period of at least four (4) hours prior to this test. (572.35(c)(v))  
Record the maximum temperature \_\_\_\_\_  
Record the minimum temperature \_\_\_\_\_  
Record the maximum humidity \_\_\_\_\_  
Record the minimum humidity \_\_\_\_\_
5. Seat the dummy on the rigid seat fixture. (572.35(c)(2)(ii))
6. Secure the dummy by bolting the stabilizer insert and the pelvis upper support device to the seat back of the test fixture as shown in Figures 17A, 18A, and 19A. (572.35(c)(2)(ii))
7. Adjust the threaded rods until plane B is horizontal.
8. Secure the lever arm into the left femur shaft opening of the upper leg structure assembly (78051-43) and firmly secure it using the 3/8-16 socket head cap screws (Figure 19A). (572.35(c)(2)(iii))
9. Lift the lever arm parallel to the midsagittal plane at a rotation rate between 5 and 10 degrees per second while maintaining the ½ in. shoulder bolt longitudinal centerline horizontal throughout the range of motion until the 150 ft-lbf torque level is reached (Figures 18A and 19A). (572.35(c)(2)(iv))

\_\_10. Complete the following table:

Left Hip Joint-Femur Flexion Results (572.35(c)(1) & (c)(2)(iv))

Parameter	Specification	Result
Rotation Rate	$5^{\circ} \leq \text{rotation rate} \leq 10^{\circ}$	
Femur Torque at $30^{\circ}$	torque $\leq 70$ ft-lbf	
Rotation at 150 lbf-ft	$40^{\circ} \leq \text{rotation} \leq 50^{\circ}$	

\_\_11. Secure the lever arm into the right femur shaft opening of the upper leg structure assembly (78051-44) and firmly secure it using the 3/8-16 socket head cap screws (Figure 19A). (572.35(c)(2)(iii))

\_\_12. Lift the lever arm parallel to the midsagittal plane at a rotation rate between 5 and 10 degrees per second while maintaining the 1/2 in. shoulder bolt longitudinal centerline horizontal throughout the range of motion until the 150 ft-lbf torque level is reached (Figures 18A and 19). (572.35(c)(2)(iv))

\_\_13. Complete the following table:

Right Hip Joint-Femur Flexion Results (572.35(c)(1) & (c)(2)(iv))

Parameter	Specification	Result
Rotation Rate	$5^{\circ} \leq \text{rotation rate} \leq 10^{\circ}$	
Femur Torque at $30^{\circ}$	torque $\leq 70$ ft-lbf	
Rotation at 15 lbf-ft	$40^{\circ} \leq \text{rotation} \leq 50^{\circ}$	

\_\_\_\_\_  
Signature

\_\_\_\_\_  
Date

### PELVIC BONE STABLIZER INSERT

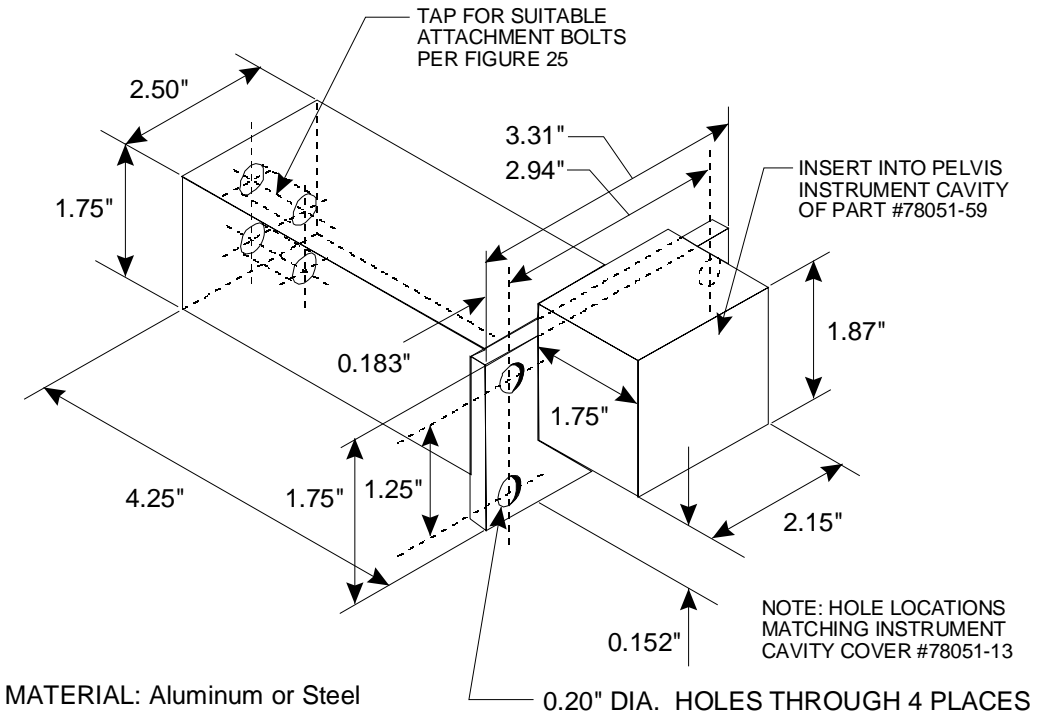

**FIGURE 15A**

### PELVIS UPPER SUPPORT DEVICE

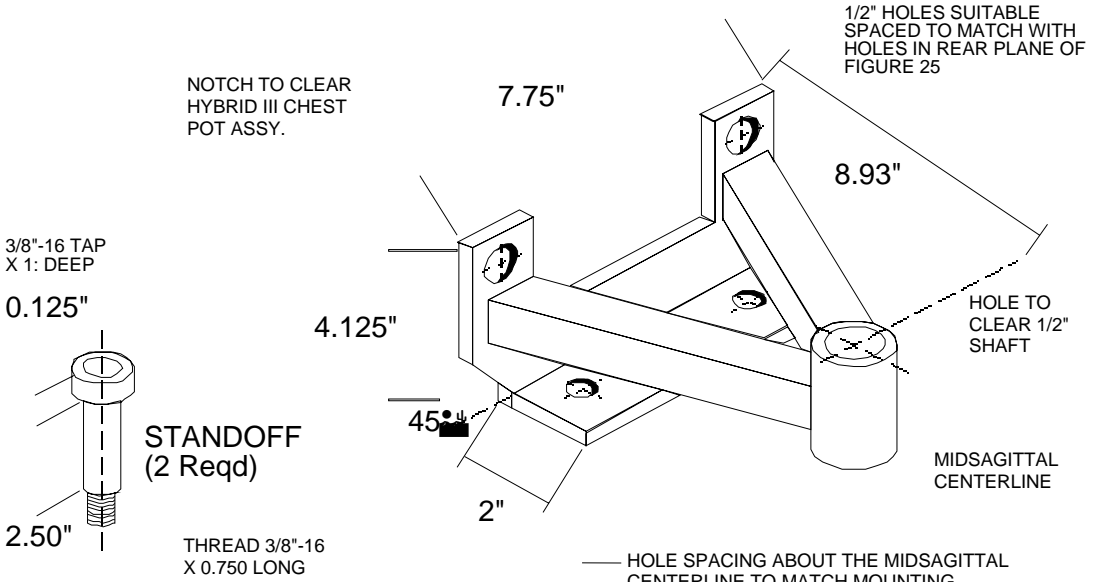

MATERIAL: CRS Steel

**FIGURE 16A**

### HIP-JOINT TEST FIXTURE ASSEMBLY

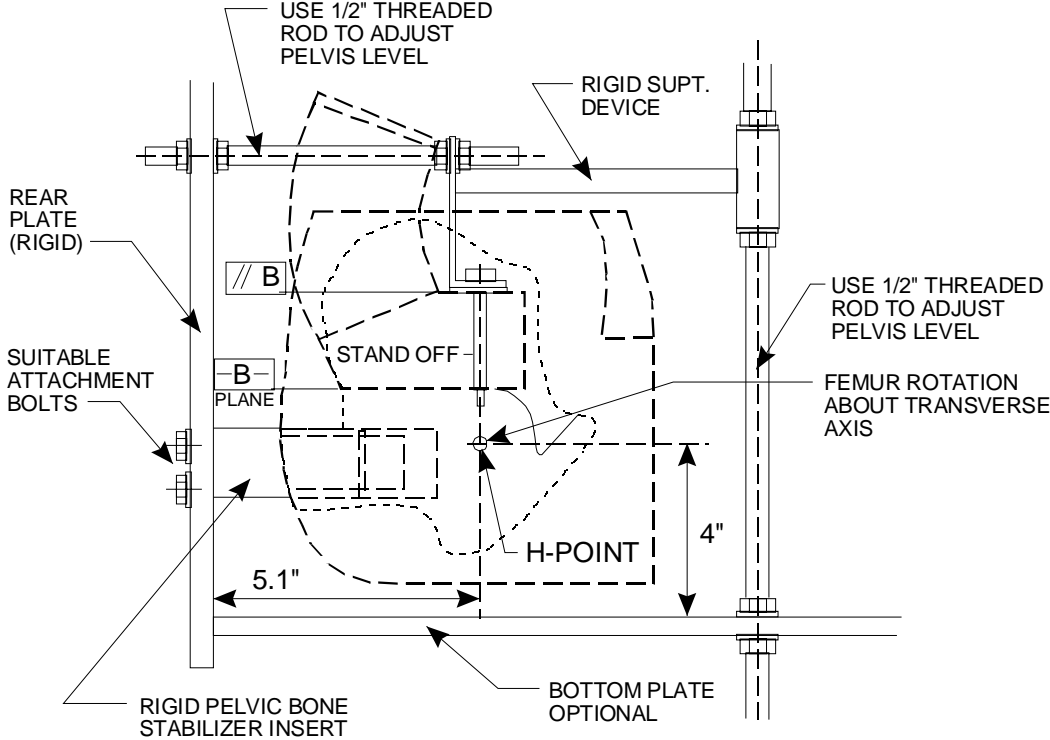

FIGURE 17A

# HIP JOINT TEST FIXTURE AND TORSO ASSEMBLY

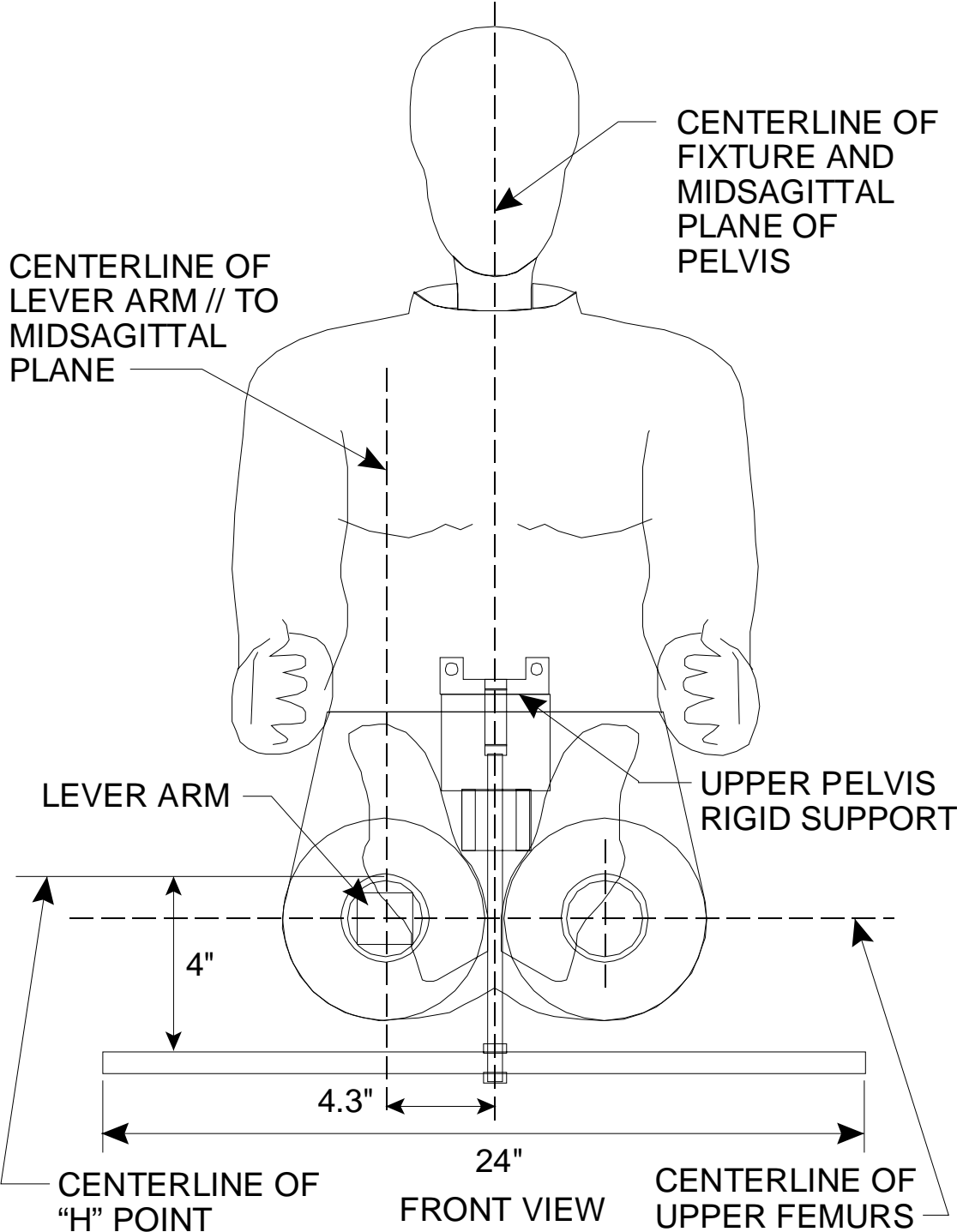
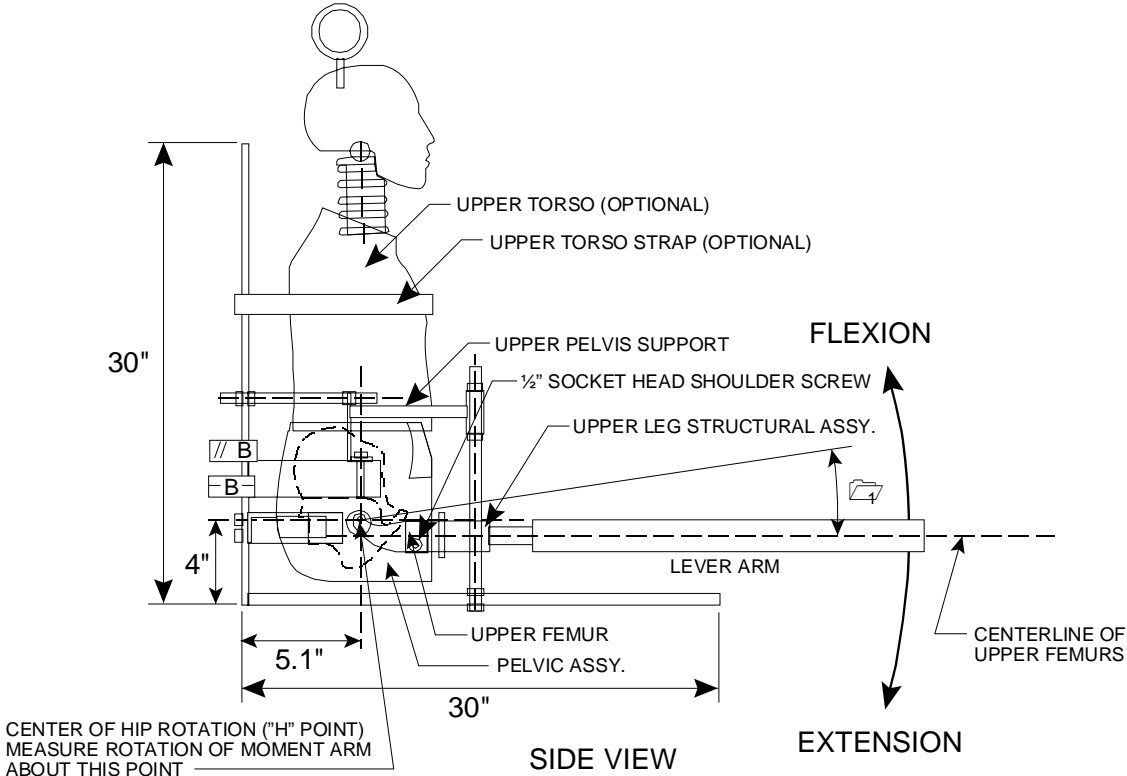

FIGURE 18A

### HIP JOINT TEST FIXTURE AND TORSO ASSEMBLY



**FIGURE 19A**

**DATA SHEET A10**  
**PART 572 INSTRUMENTATION CALIBRATION INFORMATION**

I.D. NO.	MANUFACTURER	MODEL NO.	SERIAL NO.	DATE OF LAST CALIBRATION	DATE OF NEXT CALIBRATION
<b>DUMMY INSTRUMENTATION</b>					
<b>HEAD ACCELEROMETERS</b>					
(1) LONGITUDINAL					
(2) LATERAL					
(3) VERTICAL					
NECK TRANSDUCER					
<b>CHEST ACCELEROMETERS</b>					
(1) LONGITUDINAL					
(2) LATERAL					
(3) VERTICAL					
CHEST POTENTIOMETER					
<b>FEMUR LOAD CELLS</b>					
(1) RIGHT FEMUR					
(2) LEFT FEMUR					
<b>LABORATORY INSTRUMENTATION</b>					
NECK PENDULUM ACCELEROMETER					
THORAX PENDULUM ACCELEROMETER					
KNEE PENDULUM ACCELEROMETER					
NECK ROTATION TRANSDUCER 1 (OPTIONAL)					
NECK ROTATION TRANSDUCER 2 (OPTIONAL)					

LABORATORY TECHNICIAN: \_\_\_\_\_