



U.S. Department
of Transportation

**National Highway
Traffic Safety
Administration**

400 Seventh Street, S.W.
Washington, D.C. 20590

Dear Crash Data Researchers/Users:

Thank you for choosing crash data from the National Highway Traffic Safety Administration (NHTSA) for your research or other use. The information contained in this motor vehicle crash report is collected, maintained and distributed in accordance with Public Law 89-564. In accordance with this Public Law, NHTSA is required not to release any case information until completion of quality control procedures. These procedures include a review of the case material to extract all names, licenses and registration numbers, non-coded interview material, non-research related researcher comments in the margins, non-factual data, and the production number portion of the vehicle identification number (VIN).

If you requested NHTSA to query its database files in order to identify a specific crash, then that query was made using non-personal descriptors you provided for use in our search. This motor vehicle crash may have been identified from a data search and matches the general, non-personal descriptors you provided, but we cannot confirm that this is the specific crash report you requested.

If you have any questions with regard to the above procedures, please contact the Field Operations Branch, Crash Investigation Division, National Center for Statistics and Analysis at 202-366-4820. Again, please be advised that we cannot confirm that this is the case that you have specifically requested nor can we certify the information to be correct.

*** **



AUTO SAFETY HOTLINE
(800) 424-9393
Wash. D.C. Area 366-0123



(BN) PEDESTRIAN CASE SUMMARY

PSU 410 CASE NO. G08P TYPE OF ACCIDENT CAR/PEDESTRIAN/Crossing Road straight

A. DESCRIPTION OF THE ACCIDENT SEQUENCE AND ACCIDENT PECULIARITIES

(Provide a summary of the accident sequence as well as any particular event of the accident that is noteworthy. Pedestrian injury mechanism and vehicle interaction is the focus, not pedestrian or driver culpability. Do not include any personal identifiers.)

DRIVER OF VEHICLE 1 WAS ATTEMPTING TO MAKE A LEFT TURN FROM A ONE WAY STREET TO A ONE way street. DRIVER WAS ORIGINALLY TRAVELING IN AN EAST DIRECTION, TURNING LEFT FOR A NORTH heading. VEHICLE DID STRIKE PEDESTRIAN AT CROSS WALK IN INTERSECTION. PEDESTRIAN WAS WALKING IN A SOUTH DIRECTION.

B. PEDESTRIAN PROFILE

| Pedestrian No. | Age | Sex | Treatment/Mortality | Most Severe Injury (TO BE COMPLETED BY ZONE CENTER) | | | |
|----------------|-----|--------|----------------------|--|-------------|-----|------------------------------|
| | | | | Body Region | Ana. Struc. | AIS | Injury Source |
| 01 | 22 | FEMALE | Transported/Released | Lower extremity | SKIN-OTHER | 1 | FRONT FENDER SIDE-SURFACE... |

| Body Region | Type of Anatomic Structure | Abbreviated Injury Scale |
|-----------------|----------------------------|-------------------------------|
| Head | Whole Area | (1) Minor injury |
| Face | Vessels | (2) Moderate injury |
| Throat | Nerves | (3) Serious injury |
| Chest | Organs | (4) Severe injury |
| Abdomen/Pelvis | Skeletal | (5) Critical injury |
| Spine | Head-LOC | (6) Maximum (untreatable) |
| Upper Extremity | Skin-Burn | (7) Injured, unknown severity |
| Lower Extremity | Skin-Other | |
| External | | |

C. VEHICLE PROFILE

| Vehicle No. | Class of Vehicle | Year/Make/Model | Most Severe Damage Based on Vehicle Inspection | |
|-------------|------------------|-----------------------|---|-------------------------|
| | | | Damage Plane | Damage Description |
| 01 | Compact | 90 Honda Prelude 2.0S | Left Side | Surface scratching only |

DO NOT SANITIZE THIS FORM



ACCIDENT COLLISION DIAGRAM

(BN)

PSU No. 40

Case Number-Stratum 608P

Indicate
North

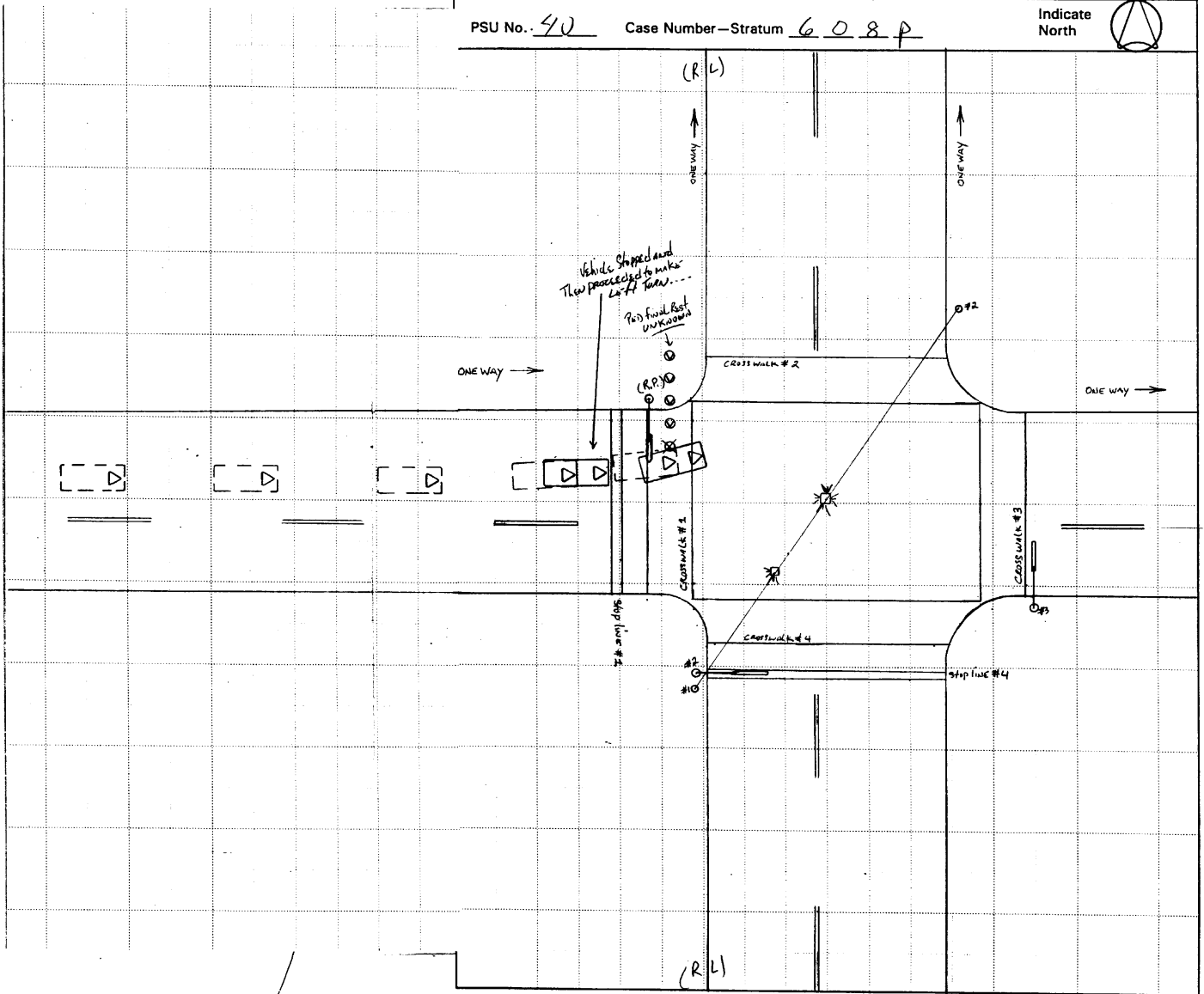



ACCIDENT COLLISION DIAGRAM

(BN)

PSU No. 40

Case Number—Stratum 608P

Indicate North

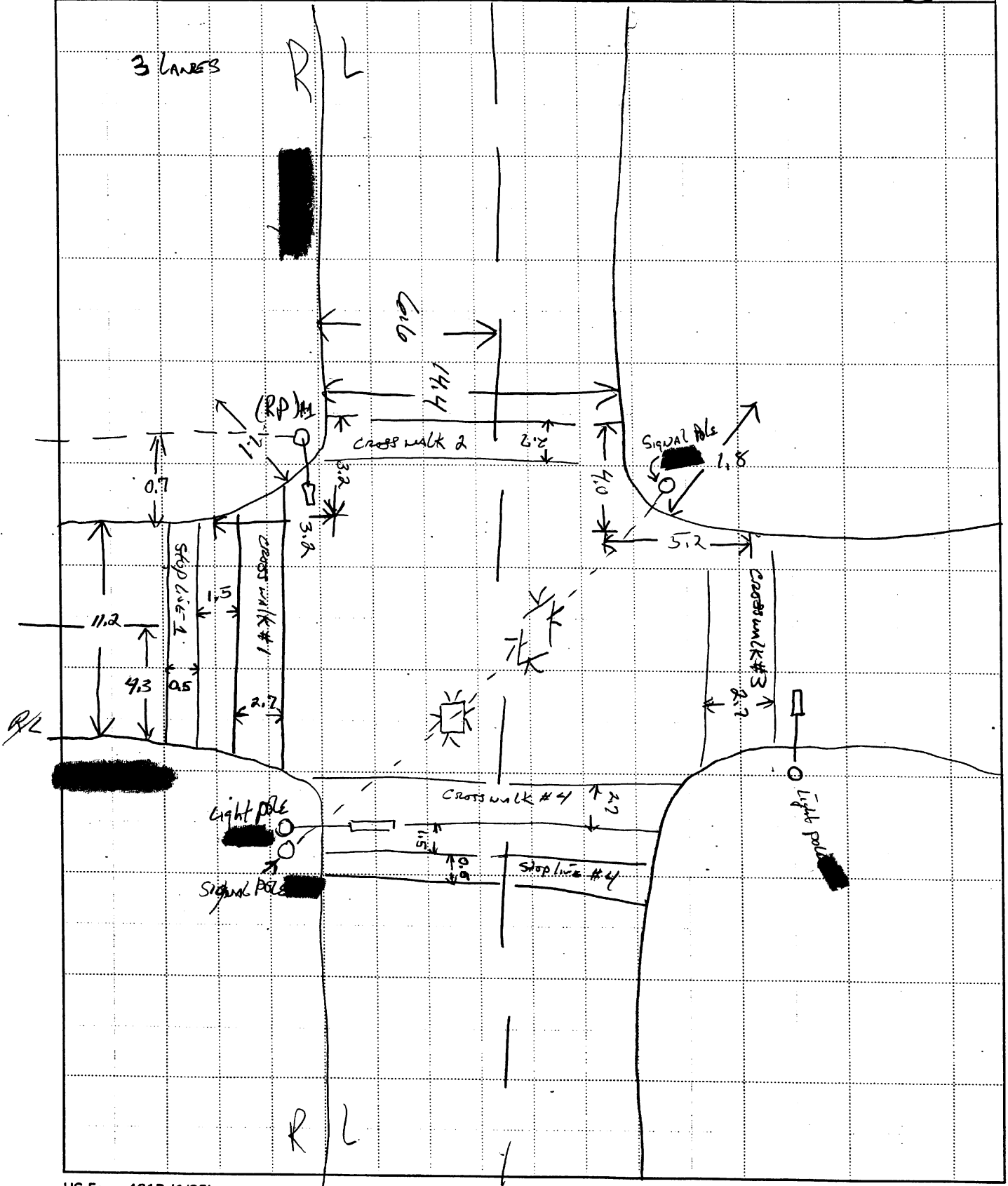



PEDESTRIAN ACCIDENT COLLISION MEASUREMENT TABLE

Primary Sampling Unit Number 40

Case Number-Stratum 6 0 5 P
B J

| PEDESTRIAN ACCIDENT COLLISION DATA COLLECTION | | SCALED DIAGRAM |
|---|--|--|
| <ul style="list-style-type: none"> document reference point and reference line relative to physical features | Surface Type <u>Asphalt</u> | <ul style="list-style-type: none"> north arrow placed on diagram |
| <ul style="list-style-type: none"> documentation of all accident induced physical evidence including (if applicable): <ul style="list-style-type: none"> a) vehicle skid marks b) pedestrian contacts with ground or object c) vehicle/pedestrian point of impact (POI) d) location of pedestrian separation point from vehicle f) final resting points (FRP) for pedestrian and vehicle | Surface Condition <u>DRY</u> Coefficient of Friction _____ Grade (v/h) Measurement a) at impact <u>0.0</u> b) between impact and final rest <u>0.0</u> | <ul style="list-style-type: none"> grade measurements for all applicable roadways scaled representations of the physical plant including: <ul style="list-style-type: none"> a) all road/roadway delineation (e.g., crosswalks, curb/edge lines, lane markings, medians, pavement markings, parked vehicles, poles, signs, etc.) b) all traffic controls (e.g., lights, signs) scaled representations of the vehicle and pedestrian at pre-impact, impact, and final rest based upon either: <ul style="list-style-type: none"> a) physical evidence, or b) reconstructed accident dynamics |
| <ul style="list-style-type: none"> documentation of the physical plant including: <ul style="list-style-type: none"> a) all road/roadway delineation (e.g., crosswalks, curb/edge lines, lane markings, medians, pavement markings, parked vehicles, poles, signs, etc.) b) all traffic controls (e.g., lights, signs) | Pedestrian Travel Direction <u>South?</u> Vehicle Travel Direction <u>MAKING LEFT TURN EAST TO NORTH</u> Number of Travel Lanes <u>2 PLUS 1 PARKING LANE</u> | |

Reference Point: RP = Light pole at NW corner
3.5' WEST of R.L. 0.7' NORTH of NORTH Road Edge

Reference Line: WEST ROAD EDGE

| Item | Distance and Direction from Reference Point | Distance and Direction from Reference Line |
|----------------------------------|---|--|
| RP Light pole NW corner ✓ | 0.0 | 3.5 WEST |
| Crosswalk #1 (EAST LINE ONLY) ✓ | 2.6 EAST | 0.8 WEST |
| Stopline #1 ✓ | 1.6 WEST | 5.2 WEST |
| Crosswalk #2 (WEST LINE ONLY) ✓ | 2.4 NORTH | — |
| Light pole SW corner ✓ | 16.7 SOUTH | 0.6 WEST |
| Signal pole SW corner ✓ | 17.6 SOUTH | 0.7 WEST |
| Signal pole N/E corner ✓ | 5.5 NORTH | 15.1 EAST |
| Crosswalk #3 (WEST LINE ONLY) ✓ | — | 16.4 WEST |
| Light pole S/E corner ✓ | 12.6 SOUTH | 19.6 EAST |
| Crosswalk #4 (NORTH LINE ONLY) ✓ | 12.2 SOUTH | — |
| Stopline #4 | 16.4 SOUTH | — |

11.2
0.7
11.9



PEDESTRIAN ACCIDENT FORM

1. Primary Sampling Unit Number 40
 2. Case Number - Stratum 608P
BN

IDENTIFICATION

3. Number of General Vehicle Forms Submitted 01
 4. Date of Accident (Month, Day, Year) / / 96
 5. Time of Accident 1540
 Code reported military time of accident.
 NOTE: Midnight = 2400
 Unknown = 9999

SPECIAL STUDIES - INDICATORS

Check (✓) each special study (SS15-SS19 below) that has been completed; code 1 for the checked special studies and 0 for the special studies not checked.

6. SS15 Administrative Use 0
 7. ✓ SS16 Pedestrian Crash Data Study 1
 8. SS17 Impact Fires 0
 9. SS18 0
 10. SS19 0

NUMBER OF EVENTS

11. Number of Recorded Events in This Accident 01

PEDESTRIAN STUDY CRITERIA

Pedestrian Definition:

Any person who is on a trafficway or on a sidewalk or path contiguous with a trafficway, or on private property (e.g., parking lot). Note: Pedestrians include persons who are in contact with the ground, roadway, etc. and are pushing carts, wagons, etc. or holding on to a vehicle.

Persons in or on a nonmotorist conveyance are not pedestrians and are excluded from this study. A nonmotorist conveyance is defined as any human powered device by which a nonmotorist may move, or by which a pedestrian or nonmotorist may move another nonmotorist. A nonmotorist conveyance for purposes of this study includes the following: bicycles, baby carriages, roller skates/blades, push carts, scooters, wheelchairs, animals, etc. For example, persons on a bicycle/scooter, roller skating/blading, in a baby carriage/push cart/wheelchair or on a horse are excluded.

Case Selection Criteria:

A forward moving, late model year (VEH04 equals 90 to 95) CDS applicable vehicle (VEH07 equals 01 to 49) must strike a pedestrian.

The striking portion of the vehicle structure must be original equipment manufacturer (OEM) without previous damage and or parts removed in the impact area. For example, vehicles equipped with deer guards, winches, snow plows, etc. or previously damaged in the impact area are excluded.

The pedestrian may not be lying or sitting.

The pedestrian impact(s) are the vehicle's only impact(s). If multiple pedestrians are impacted, each pedestrian shall be a separate case.

The first point of contact between the late model year, CDS applicable vehicle and the pedestrian must be forward of the top of the A pillar.

PEDESTRIAN ACCIDENT EVENTS

| Accident Event Sequence Number | Vehicle Number | Class Of Vehicle | General Area of Damage | Vehicle Number or Object Contacted | Class Of Vehicle | General Area of Damage |
|--------------------------------|----------------|------------------|------------------------|------------------------------------|------------------|------------------------|
| 12. <u>01</u> | 13. <u>01</u> | 14. <u>02</u> | 15. <u>L</u> | 16. <u>72</u> | 17. <u>00</u> | 18. <u>0</u> |

**CODES FOR
CLASS OF VEHICLE**

- (00) Not a motor vehicle
- (01) Subcompact/mini (wheelbase < 254 cm)
- (02) Compact (wheelbase ≥ 254 but < 265 cm)
- (03) Intermediate (wheelbase ≥ 265 but < 278 cm)
- (04) Full size (wheelbase ≥ 278 but < 291 cm)
- (05) Largest (wheelbase ≥ 291 cm)
- (09) Unknown passenger car size
- (11) Compact utility vehicle
- (12) Large utility vehicle (≤ 4,500 kgs GVWR)
- (13) Passenger van (≤ 4,500 kgs GVWR)
- (14) Other van (≤ 4,500 kgs GVWR)
- (15) Pickup truck (≤ 4,500 kgs GVWR)
- (18) Other truck (≤ 4,500 kgs GVWR)
- (19) Unknown light truck type

**CODES FOR GENERAL AREA
OF DAMAGE (GAD)**

**CDS APPLICABLE
VEHICLES**

- (F) Front
- (R) Right side
- (L) Left side
- (U) Undercarriage
- (9) Unknown

CODES FOR VEHICLE NUMBER OR OBJECT CONTACTED

Collision with Nonfixed Object

- (72) Pedestrian

PEDESTRIAN ASSESSMENT FORM

1. Primary Sampling Unit Number 40
 2. Case Number - Stratum 608P
 (BN)
 3. Pedestrian Number 01

10. Pedestrian's Weight 999
 Code actual weight to the nearest
 kilogram.
 (999) Unknown
 _____ pounds X .4536 = _____ kilograms

PEDESTRIAN'S CHARACTERISTICS

4. Pedestrian's Age 22
 Code actual age at time of accident.
 (00) Less than one year old (specify by month): _____
 (97) 97 years and older
 (99) Unknown

5. Pedestrian's Sex 2
 (1) Male
 (2) Female - not reported pregnant
 (3) Female - pregnant-1st trimester (1st-3rd month)
 (4) Female - pregnant-2nd trimester (4th-6th month)
 (5) Female - pregnant-3rd trimester (7th-9th month)
 (6) Female - pregnant-term unknown
 (9) Unknown

6. Pedestrian's Overall Height 999
 Code actual height to the nearest
 centimeter.
 (999) Unknown
 _____ inches X 2.54 = _____ centimeters

7. Pedestrian's Height - Ground to Knee 99
 Code to the nearest
 centimeter.
 (999) Unknown
 _____ inches X 2.54 = _____ centimeters

8. Pedestrian's Height - Ground to Hip 999
 Code to the nearest
 centimeter.
 (999) Unknown
 _____ inches X 2.54 = _____ centimeters

9. Pedestrian's Height - Ground to Shoulder 999
 Code to the nearest
 centimeter.
 (999) Unknown
 _____ inches X 2.54 = _____ centimeters

PEDESTRIAN'S PRE-AVOIDANCE ACTIONS

11. Pedestrian Attitude 1
 (1) Standing
 (2) Crouching
 (3) Kneeling
 (4) Bending at waist
 (8) Other (specify): _____
 (9) Unknown

12. Pedestrian Motion 9
 (0) Not moving
 (1) Walking slowly
 (2) Walking rapidly
 (3) Running or jogging
 (4) Hopping
 (5) Skipping
 (6) Jumping
 (7) Falling/stumbling or rising
 (8) Other (specify): _____
 (9) Unknown

13. Pedestrian's Action Relative to Vehicle 01
 (00) Stopped
 (01) Crossing road, straight *No Pedestrian*
 (02) Crossing road, diagonally *Interview...*
 (03) Moving in road, with traffic
 (04) Moving in road, against traffic
 (05) Off road, approaching road
 (06) Off road, going away from road
 (07) Off road, moving parallel
 (08) Off road, crossing driveway
 (09) Off road, moving along driveway
 (98) Other (specify): _____
 (99) Unknown

14. Pedestrian's Body (Chest) Orientation 4
 Relative to Striking Vehicle Prior to
 Avoidance Actions
 (1) Facing vehicle
 (2) Facing away
 (3) Left side to vehicle
 (4) Right side to vehicle
 (8) Other (specify): _____
 (9) Unknown

PEDESTRIAN'S AVOIDANCE ACTIONS15. Pedestrian's First Avoidance Actions 1 3*

- (00) No avoidance actions
- (01) Stopped
- (02) Accelerated pace
- (03) Ran away (along vehicle path)
- (04) Jumped
- (05) Turned toward vehicle
- (06) Turned away from vehicle
- (07) Dove or fell away

Used hand(s) to :

- (11) Vault corner of vehicle
- (12) Vault onto vehicle
- (13) Brace against vehicle
- (14) Crouched and braced hands against vehicle
- (98) Other (specify): _____
- (99) Unknown

PEDESTRIAN'S ORIENTATION AT IMPACT16. Pedestrian's Head Orientation at Initial Impact 9

- (1) To front
- (2) To left
- (3) To right
- (4) Up
- (5) Down
- (8) Other (specify): _____
- (9) Unknown

17. Pedestrian's Body (Chest) Orientation at Initial Impact 4

- (1) Facing vehicle
- (2) Facing away
- (3) Left side to vehicle
- (4) Right side to vehicle
- (8) Other (specify): _____
- (9) Unknown

18. Pedestrian's Arm Orientation at Initial Impact 9 9

- (01) At sides
- (02) Folded across chest
- (03) Hands clasped behind back
- (04) Hands on hips
- (05) Hands in pockets

One or both arms:

- (06) Extended upward
- (07) Extended to side
- (08) Extended forward bracing
- (09) Extended, holding object (briefcase, suitcase, etc.)
- (10) Holding object (young child, grocery bag, etc.) in arm(s)
- (11) Holding object (young child, grocery bag, etc.) on shoulder(s) or head
- (98) Other (specify): _____
- (99) Unknown

19. Pedestrian's Leg Orientation at Initial Impact 9 9

- (01) Together
- (02) Apart-laterally
- (03) Apart-right leg forward
- (04) Apart-left leg forward
- (05) Apart- forward leg unknown
- (06) Left foot off the ground
- (07) Right foot off the ground
- (08) Both feet off the ground
- (98) Other (specify): _____
- (99) Unknown

20. Vehicle/Pedestrian's Interaction 1 4*

- (01) Carried by vehicle, wrapped position
- (02) Carried by vehicle, slid to windshield
- (03) Carried by vehicle, position unknown
- (04) Passed over vehicle top
- (05) Thrown straight forward
- (06) Thrown forward and left of vehicle
- (07) Thrown forward and right of vehicle
- (08) Knocked to pavement, forward
- (09) Knocked to pavement, left of vehicle
- (10) Knocked to pavement, right of vehicle
- (11) Knocked to pavement, run over or dragged by vehicle
- (12) Shunted to left (corner impacts only)
- (13) Shunted to right (corner impacts only)
- (14) Bumped or pushed aside
- (15) Snagged, rotated
- (16) Snagged, dragged by vehicle
- (17) Foot or legs run over
- (98) Other (specify): _____
- (99) Unknown

* According to Driver Interview

STOP - VARIABLES 30 THROUGH 37 ARE COMPLETED BY THE ZONE CENTER

30. Glasgow Coma Scale (GCS) Score 15
(at Medical Facility)

- (00) Not injured
(01) Injured - not treated at medical facility
(02) No GCS Score at medical facility
(03-15) Code the actual value of the initial GCS Score recorded at medical facility.
(97) Injured, details unknown
(99) Unknown if injured

31. Was the Pedestrian Given Blood? 1

- (1) No - blood not given
(2) Yes - blood given
(specify units): _____
(9) Unknown if blood given

32. Arterial Blood Gases (ABG) - HCO₃ 01

- (00) Not injured
(01) Injured, ABGs not measured or reported
(02-50) Code the actual value of the HCO₃
(96) ABGs reported, HCO₃ unknown
(97) Injured, details unknown
(99) Unknown if injured

33. Time to Death 00

- Code number of hours from time of accident to time of death up through 24 hours. If time of death is greater than 24 hours, code number of days. (Note: 1 day = 31, 2 days = 32, ... n days = 30 + n up through 30 days = 60)
(00) Not fatal
(96) Fatal - ruled disease
(99) Unknown

34. 1st Medically Reported Cause of Death 00

35. 2nd Medically Reported Cause of Death 00

36. 3rd Medically Reported Cause of Death 00

Code the Pedestrian Injury from line number(s) for the medically reported injury(s) which reportedly contributed to this pedestrian's death

- (00) Not fatal or no additional causes
(96) Mode of death given but specific injuries are not linked to cause of death. (specify): _____
(97) Other result (includes fatal ruled disease) (specify): _____
(99) Unknown

37. Number of Recorded Injuries for This Pedestrian 02

Code the actual number of injuries recorded for this pedestrian.

- (00) No recorded injuries
(97) Injured, details unknown
(99) Unknown if injured

ARE ALL APPLICABLE MEDICAL RECORDS INCLUDED WITH INITIAL SUBMISSION?

NO [] YES

UPDATE CANDIDATE? NO YES []



PEDESTRIAN INJURY FORM

| | |
|---|--------------------------------|
| 1. Primary Sampling Unit Number <u>40</u> | 3. Pedestrian Number <u>01</u> |
| 2. Case Number - Stratum <u>608P</u> <u>3N</u> | 4. Blank <u>XX</u> |

INJURY DATA

Record below the actual injuries sustained by this pedestrian in **CHRONOLOGICAL** order that were identified from the official and unofficial data sources. Remember not to double count an injury just because it was identified from two different sources. If greater than twenty-five injuries have been documented, encode the balance on the Pedestrian Injury Supplement.

*lumbal
muscle
1st*
2nd
3rd
4th
5th
6th
7th
8th
9th
10th

| Source of Injury Data | AIS-90 | | | | | | | Injury Source | Injury Confidence Level | Direct/Indirect Injury | Striking Profile | Type Of Damage | Damage Depth |
|-----------------------|-------------|----------------------------|-----------------------------|-----------------|-----------------|--------|---------------|---------------|-------------------------|------------------------|------------------|----------------|--------------|
| | Body Region | Type of Anatomic Structure | Specific Anatomic Structure | Level of Injury | A.I.S. Severity | Aspect | Injury Source | | | | | | |
| 5th | 3 | 4 | 4 | 06 | 78 | 1 | 8 | 997 | 2 | 3 | 0 | 0 | 0 |
| 18th | 3 | 8 | 9 | 04 | 02 | 1 | 1 | 720 | 1 | 1 | 4 | 2 | 2 |
| 3rd | 31 | 32 | 33 | 34 | 35 | 36 | 37 | 38 | 39 | 40 | 41 | 42 | 43 |
| 4th | 44 | 45 | 46 | 47 | 48 | 49 | 50 | 51 | 52 | 53 | 54 | 55 | 56 |
| 5th | 57 | 58 | 59 | 60 | 61 | 62 | 63 | 64 | 65 | 66 | 67 | 68 | 69 |
| 6th | 70 | 71 | 72 | 73 | 74 | 75 | 76 | 77 | 78 | 79 | 80 | 81 | 82 |
| 7th | 83 | 84 | 85 | 86 | 87 | 88 | 89 | 90 | 91 | 92 | 93 | 94 | 95 |
| 8th | 96 | 97 | 98 | 99 | 100 | 101 | 102 | 103 | 104 | 105 | 106 | 107 | 108 |
| 9th | 109 | 110 | 111 | 112 | 113 | 114 | 115 | 116 | 117 | 118 | 119 | 120 | 121 |
| 10th | 122 | 123 | 124 | 125 | 126 | 127 | 128 | 129 | 130 | 131 | 132 | 133 | 134 |

OFFICIAL INJURY DATA — SOFT TISSUE INJURIES

Indicate the Location, Specific Anatomic Structure, Detail (size, depth, fracture type, head injury clinical signs and neurological deficits), and Source of all injuries indicated by official sources (or from PAR or other unofficial sources if medical records and interviewee data are unavailable.)

ER: CAR STRUCK RT LEG

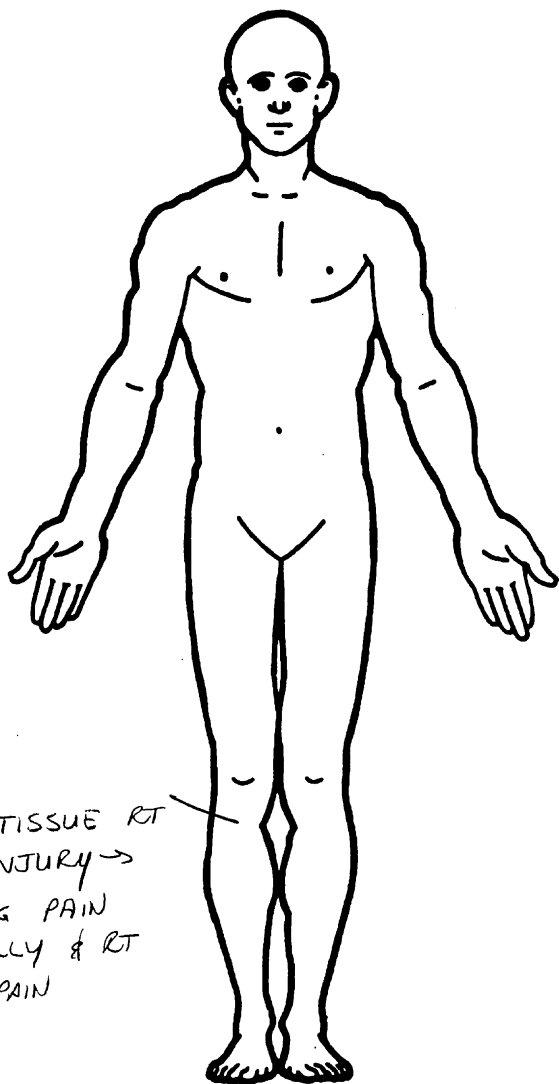

ER:
SOFT TISSUE RT
LEG INJURY →
RT LEG PAIN
LATERALLY & RT
KNEE PAIN

ER:
LUMBAR MUSCLE
STRAIN

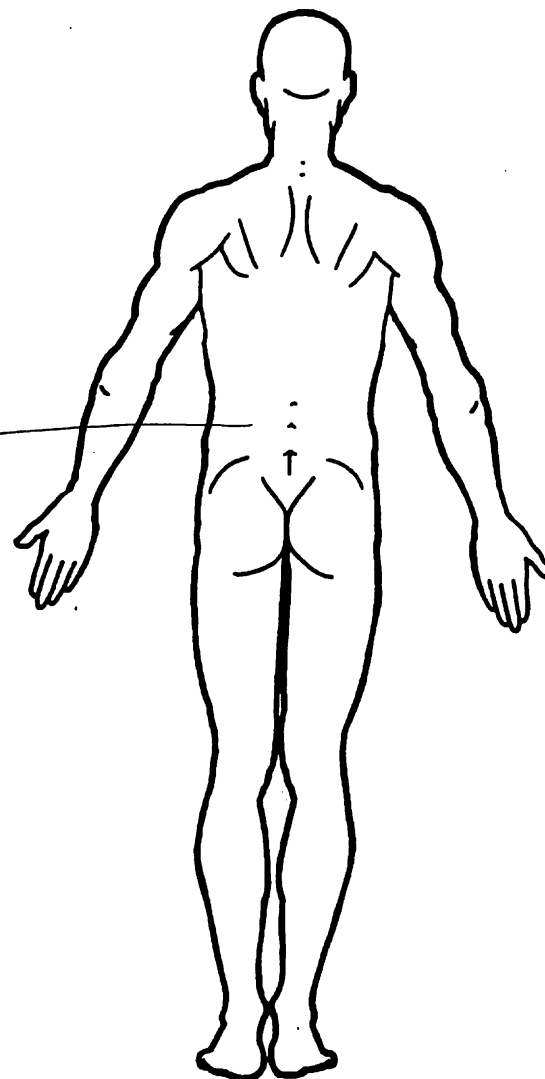

SOURCE OF INJURY DATA**OFFICIAL**

- (1) Autopsy records with or without hospital/medical records
- (2) Hospital/medical records other than emergency room (e.g., discharge summary)
- (3) Emergency room records only (including associated X-rays or other lab reports)
- (4) Private physician, walk-in or emergency clinic

UNOFFICIAL

- (5) Lay coroner report
- (6) E.M.S. personnel
- (7) Interviewee
- (8) Other source (specify): _____
- (9) Police

INJURY SOURCE CONFIDENCE LEVEL

- (1) Certain
- (2) Probable
- (3) Possible
- (9) Unknown

DIRECT/INDIRECT INJURY

- (1) Direct contact injury
- (2) Indirect contact injury
- (3) Noncontact injury
- (7) Injured, unknown source

STRIKING PROFILE

- (0) Injury not from vehicle contact
- (1) Flat-Narrow (< 15 centimeters)
- (2) Flat-Wide (> 15 centimeters)
- (3) Rounded (contoured)
- (4) Rounded edge
- (5) Sharp edge
- (8) Other (specify): _____
- (9) Unknown

TYPE OF DAMAGE

- (0) Injury not from vehicle contact
- (1) No damage/contact
- (2) Scratch (Scuff, Cloth Transfer, Smear)
- (3) Dent
- (4) Large deformation
- (5) Cracked, fractured, shattered
- (6) Separated from vehicle
- (7) Noncontact injury
- (8) Other specify: _____
- (9) Unknown

DAMAGE DEPTH

- (0) Injury not from vehicle contact
- (1) No residual damage
- (2) Surface only damage
- (3) Crush depth > 0 to 2 centimeters
- (4) Crush depth > 2 to 5 centimeters
- (5) Crush depth > 5 to 10 centimeters
- (8) Other specify: _____
- (9) Unknown

PEDESTRIAN INJURY CLASSIFICATION**Body Region**

- (1) Head
- (2) Face
- (3) Neck
- (4) Thorax
- (5) Abdomen
- (6) Spine
- (7) Upper Extremity
- (8) Lower Extremity
- (9) Unspecified

Specific Anatomic StructureWhole Area

- (02) Skin - Abrasion
- (04) Skin - Contusion
- (06) Skin - Laceration
- (08) Skin - Avulsion
- (10) Amputation
- (20) Burn
- (30) Crush
- (40) Degloving
- (50) Injury - NFS
- (90) Trauma, other than mechanical

Spine

- (02) Cervical
- (04) Thoracic
- (06) Lumbar

Vessels, Nerves, Organs, Bones, Joints are assigned consecutive two digit numbers beginning with 02

Level of Injury

Specific injuries are assigned consecutive two-digit numbers beginning with 02.

To the extent possible, within the organizational framework of the AIS, 00 is assigned to an injury NFS as to severity or where only one injury is given in the dictionary for that anatomic structure. 99 is assigned to any injury NFS as to lesion or severity.

Abbreviated Injury Scale

- (1) Minor injury
- (2) Moderate injury
- (3) Serious injury
- (4) Severe injury
- (5) Critical injury
- (6) Maximum (untreatable)
- (7) Injured, unknown severity

Type of Anatomic Structure

- (1) Whole Area
- (2) Vessels
- (3) Nerves
- (4) Organs (includes muscles/ligaments)
- (5) Skeletal (includes joints)
- (6) Head - LOC
- (9) Skin

Head - LOC

- (02) Length of LOC
- (04, 06, 08) Level of Consciousness
- (10) Concussion

Aspect

- (1) Right
- (2) Left
- (3) Bilateral
- (4) Central
- (5) Anterior
- (6) Posterior
- (7) Superior
- (8) Inferior
- (9) Unknown
- (0) Whole region

INJURY SOURCEFRONT

- 700 Front bumper
- 701 Front lower valance/spoiler
- 702 Front grille
- 703 Hood edge and/or trim
- 704 Hood ornament (fixed)
- 705 Hood ornament (spring loaded)
- 706 Headlight
- 707 Retractable headlight door (Open/Closed)
- 708 Turn signal/parking lights
- 718 Other front or add on object (specify): _____
- 719 Unknown front object

Left Side Components

- 720 Front fender side surface
- 721 Front antenna
- 722 A1 pillar
- 723 A2 pillar
- 724 B pillar
- 725 C pillar
- 726 D pillar
- 728 Other pillar (specify): _____
- 729 Left side roof rail
- 730 Left side door surface
- 731 Left side door handle
- 732 Left side mirror fixed housing
- 733 Left side folding mirror
- 734 Left side glazing forward of B pillar
- 735 Left side glazing rearward of B pillar
- 736 Left side back fender or quarter panel
- 737 Rear antenna
- 738 Other left side object (specify): _____
- 739 Unknown left side component

Right Side Components

- 740 Front fender side surface
- 741 Front antenna
- 742 A1 pillar
- 743 A2 pillar

- 744 B pillar
- 745 C pillar
- 746 D pillar
- 748 Other pillar (specify): _____
- 749 Right side roof rail
- 750 Right side door surface
- 751 Right side door handle
- 752 Right side mirror fixed housing
- 753 Right side folding mirror
- 754 Right side glazing forward of B pillar
- 755 Right side glazing rearward of B pillar
- 756 Rear antenna
- 757 Rear fender or quarter panel
- 758 Other right side object (specify): _____
- 759 Unknown right side component

Back Components

- 760 Rear (back) bumper
- 761 Tailgate
- 762 Hatchback, vertical surface
- 768 Other back component (specify): _____
- 769 Unknown back component

Top Components

- 770 Hood surface
- 771 Hood surface reinforced by under hood component
- 772 Front fender top surface
- 773 Cowl area
- 774 Wiper blade & mountings
- 775 Windshield glazing
- 776 Front header
- 777 Roof surface
- 778 Backlight glazing
- 779 Rear header
- 780 Hatchback
- 781 Rear trunk lid
- 788 Other top component (specify): _____
- 789 Unknown top component

Wheels / tires

- 790 Left front wheel / tire
- 791 Right front wheel / tire
- 792 Left rear wheel / tire
- 793 Right rear wheel / tire
- 798 Other wheel / tire (specify): _____
- 799 Unknown wheel / tire

Undercarriage components

- 800 Front crossmember
- 801 Steering assembly/Front suspension
- 802 Oil pan
- 803 Exhaust system pipe
- 804 Transmission
- 805 Drive shaft
- 806 Catalytic converter
- 807 Muffler
- 808 Floor pan
- 809 Fuel tank
- 810 Rear suspension
- 818 Other undercarriage component (specify): _____
- 819 Unknown undercarriage component

Accessories

- 820 Air scoop, deflector
- 821 Cellular or CB radio antenna
- 822 Emergency lights or bar
- 823 Fog lights
- 824 Luggage, ski, or bike rack
- 825 Cargo (specify): _____
- 826 Spare tire
- 827 Spotlight
- 828 Other accessory (specify): _____

Other Object or Vehicle in Environment

- 947 Ground
- 948 Other object (specify): _____
- 949 Unknown object in environment
- 959 Unknown object on contacting vehicle
- 997 Noncontact injury source
- 999 Unknown injury source

OFFICIAL INJURY DATA — SKELETAL INJURIES

Restrained?

No

Indicate the Location, Specific Anatomic Structure, Detail (size, depth, fracture type, head injury clinical signs and neurological deficits), and Source of all injuries indicated by official sources (or from PAR or other unofficial sources if medical records and interviewee data are unavailable.)

Yes

Blood Alcohol Level
(mg/dl)

BAL = _____

Glasgow Coma
Scale Score

GCSS = 15

A x 0 x 3

Units of Blood
Given

Units = _____

Arterial Blood Gases

Ph = _____

PO₂ = _____

PCO₂ = _____

HCO₃ = _____

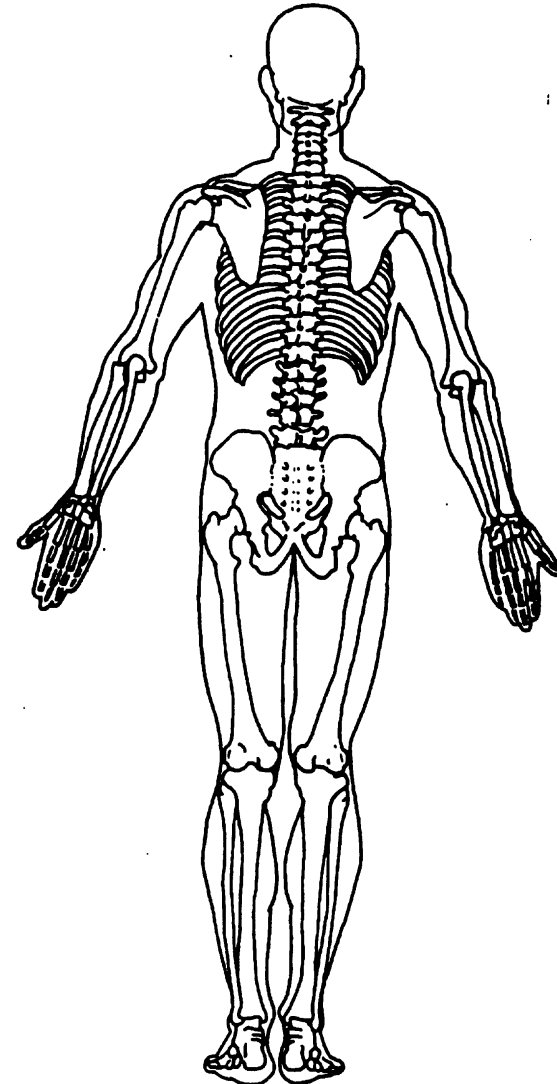
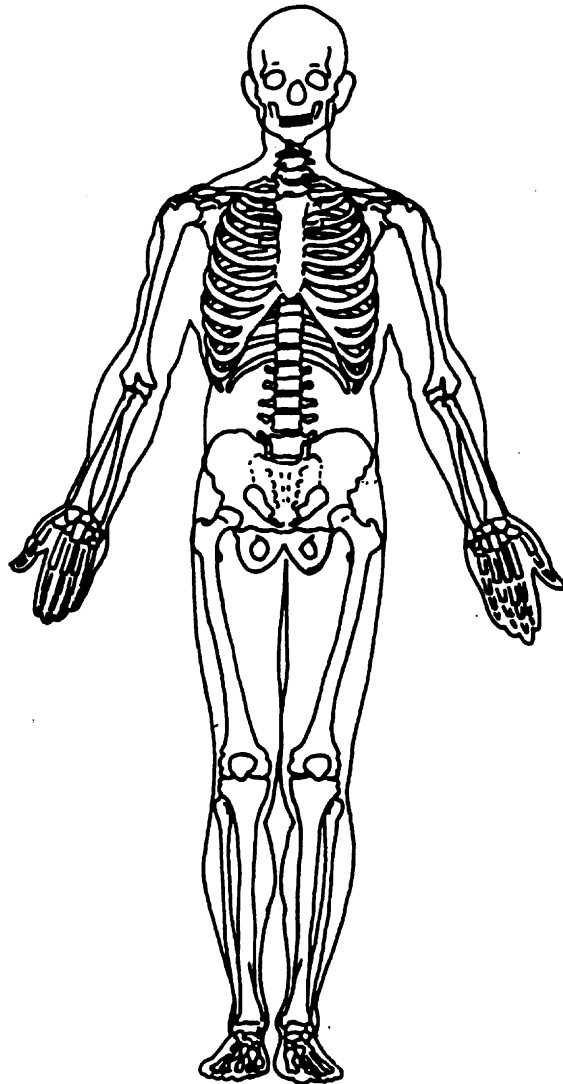

OFFICIAL INJURY DATA – INTERNAL INJURIES

Indicate the Location, Specific Anatomic Structure, Detail (size, depth, fracture type, head injury clinical signs and neurological deficits), and Source of all injuries indicated by official sources (or from PAR or other unofficial sources if medical records and interviewee data are unavailable.)

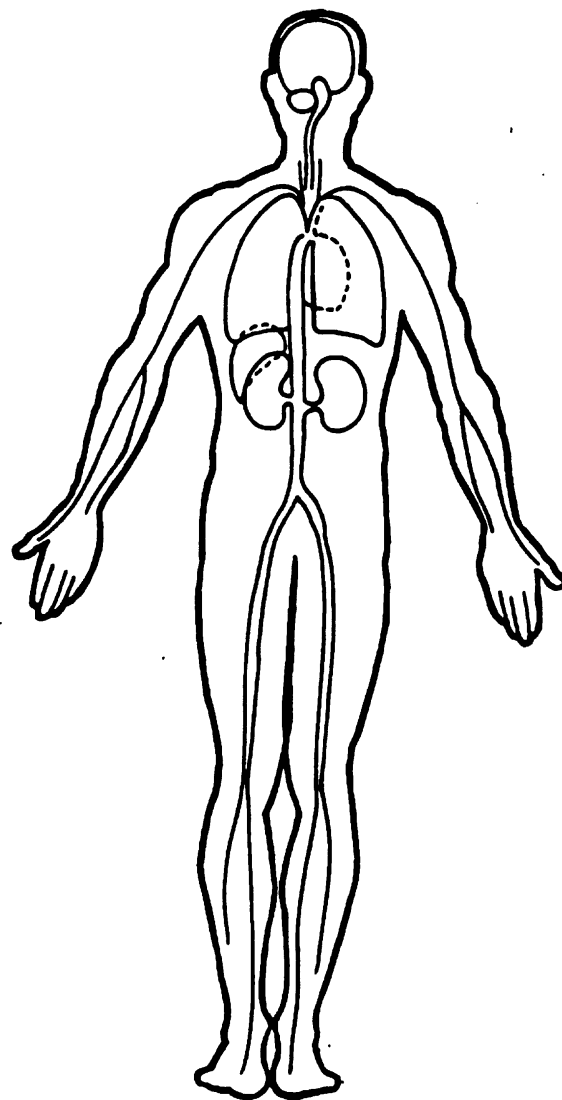
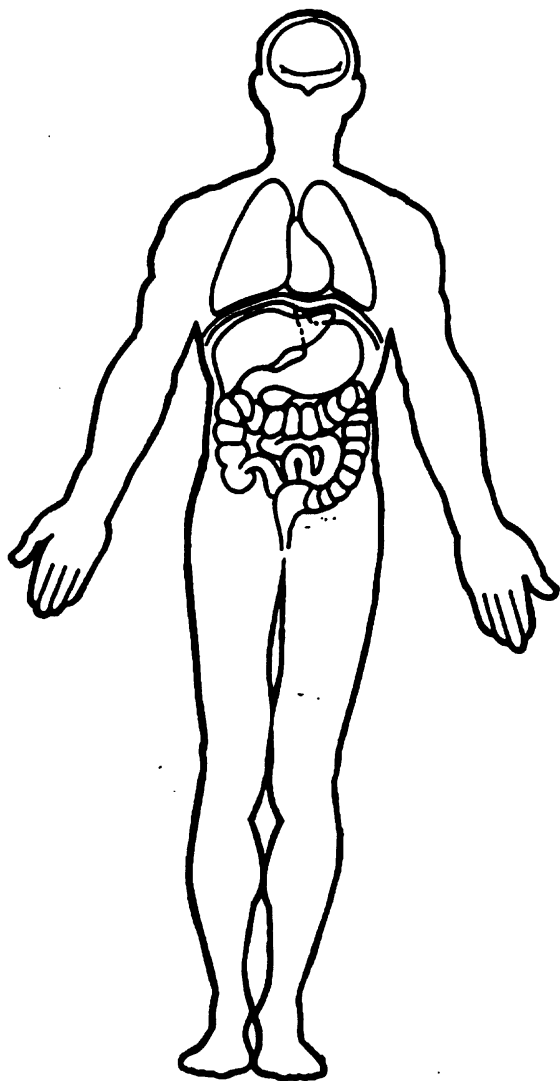

CODES FOR BODY TYPE

CDS APPLICABLE VEHICLES

Automobiles

- (01) Convertible (excludes sun-roof, t-bar)
- (02) 2-door sedan, hardtop, coupe
- (03) 3-door/2-door hatchback
- (04) 4-door sedan, hardtop
- (05) 5-door/4-door hatchback
- (06) Station wagon (excluding van and truck based)
- (07) Hatchback, number of doors unknown
- (08) Other automobile type (specify): _____
- (09) Unknown automobile type

Automobile Derivatives

- (10) Auto based pickup (includes El Camino, Caballero, Ranchero, Brat, and Rabbit pickup)
- (11) Auto based panel (cargo station wagon, auto based ambulance/hearse)
- (12) Large limousine - more than four side doors or stretched chassis
- (13) Three-wheel automobile or automobile derivative

Utility Vehicles (< 4,500 kgs GVWR)

- (14) Compact utility (Jeep CJ-2 - CJ-7, Scrambler, Golden Eagle, Renegade, Laredo, Wrangler, Cherokee [84 and after], Dispatcher, Raider, Bronco II, Bronco [76 and before], Explorer, S-10 Blazer, Geo Tracker, Bravada, S-15 Jimmy, Thing, Pathfinder, Trooper, Trooper II, Rodeo, Amigo, Navajo, 4-Runner, Montero, Samurai, Sidekick, Rocky)
- (15) Large utility (includes Jeep Cherokee [83 and before], Ramcharger, Trailduster, Bronco-fullsize [78 and after], fullsize Blazer, fullsize Jimmy, Landcruiser, Rover, Scout)
- (16) Utility station wagon (Chevy Suburban, GMC Suburban, Travelall, Grand Wagoneer, includes suburban limousine)
- (19) Utility, unknown body type

Van Based Light Trucks (< 4,500 kgs GVWR)

- (20) Minivan (Chrysler Town and Country, Caravan, Grand Caravan, Voyager, Grand Voyager, Mini-Ram, Dodge/Plymouth Vista, Aerostar, Villager, Lumina APV, Trans Sport, Silhouette, Astro, Safari, Toyota Van, Toyota Minivan, Previa, Nissan Minivan, Quest, Mitsubishi Minivan, Vanagon/Camper.)
- (21) Large van (B150-B350, Sportsman, Royal, Maxiwagon, Ram, Tradesman, Voyager [83 and before], E150-E350, Econoline, Clubwagon, Chateau, G10-G30, Chevy Van, Beauville, Sport Van, G15-G35, Rally Van, Vandura.)
- (22) Step van or walk-in van (< 4,500 kgs GVWR)
- (23) Van based motorhome (< 4,500 kgs GVWR)
- (24) Van based school bus (< 4,500 kgs GVWR)
- (25) Van based other bus (< 4,500 kgs GVWR)
- (28) Other van type (Hi-Cube Van, Kary) (specify): _____
- (29) Unknown van type

Light Conventional Trucks (Pickup style cab, < 4,500 kgs GVWR)

- (30) Compact pickup (D50, Colt P/U, Ram 50, Dakota, Arrow Pickup [foreign], Ranger, Courier, S-10, T-10, LUV, S-15, T-15, Sonoma, Datsun/Nissan Pickup, P'up, Mazda Pickup, Toyota Pickup, Mitsubishi Pickup)
- (31) Large Pickup (Jeep Pickup, Comanche, Ram Pickup, D100-D350, W100-W350, F100-F350, C10-C35, K10-K35, R10-R35, V10-V35, Silverado, Sierra, R100-R500,)

- (32) Pickup with slide-in camper
- (33) Convertible pickup
- (39) Unknown pickup style light conventional truck type

Other Light Trucks (< 4,500 kgs GVWR)

- (40) Cab chassis based (includes rescue vehicles, light stake, dump, and tow truck)
- (41) Truck based panel
- (42) Light truck based motorhome (chassis mounted)
- (45) Other light conventional truck type
- (48) Unknown light truck type
- (49) Unknown light vehicle type (automobile, utility, van, or light truck)

OTHER VEHICLES

Buses (Excludes Van Based)

- (50) School bus (designed to carry students, not cross country or transit)
- (58) Other bus type (e.g., transit, intercity, bus based motorhome) (specify): _____
- (59) Unknown bus type

Medium/Heavy Trucks (> 4,500 kgs GVWR)

- (60) Step van (> 4,500 kgs GVWR)
- (61) Single unit straight truck (4,500 kgs < GVWR ≤ 8,850 kgs)
- (62) Single unit straight truck (8,850 kgs < GVWR ≤ 12,000 kgs)
- (63) Single unit straight truck (> 12,000 kgs GVWR)
- (64) Single unit straight truck, GVWR unknown
- (65) Medium/heavy truck based motorhome
- (67) Truck-tractor with no cargo trailer
- (68) Truck-tractor pulling one trailer
- (69) Truck-tractor pulling two or more trailers
- (70) Truck-tractor (unknown if pulling trailer)
- (78) Unknown medium/heavy truck type
- (79) Unknown truck type (light/medium/heavy)

Motored Cycles (Does Not Include All-Terrain Vehicles/Cycles)

- (80) Motorcycle
- (81) Moped (motorized bicycle)
- (82) Three-wheel motorcycle or moped
- (88) Other motored cycle (minibike, motorscooter) (specify): _____
- (89) Unknown motored cycle type

Other Vehicles

- (90) ATV (All-Terrain Vehicle) and ATC (All-Terrain Cycle)
- (91) Snowmobile
- (92) Farm equipment other than trucks
- (93) Construction equipment other than trucks
- (97) Other vehicle type
- (99) Unknown body type

VEHICLE WEIGHT ITEMS

15. Vehicle Curb Weight 1,200
Code weight to nearest 10 kilograms.
(045) Less than 450 kilograms
(610) 6,100 kilograms or more
(999) Unknown

2,633 lbs X .4536 = 1,192 kgs

Source: [redacted]

16. Vehicle Cargo Weight 9,990
Code weight to nearest 10 kilograms.
(000) Less than 5 kilograms
(450) 4,500 kilograms or more
(999) Unknown

[redacted] lbs X .4536 = [redacted] kgs

OTHER DATA

17. Vehicle Special Use (This Trip) 0
(0) No special use
(1) Taxi
(2) Vehicle used as school bus
(3) Vehicle used as other bus
(4) Military
(5) Police
(6) Ambulance
(7) Fire truck or car
(8) Other (specify):
(9) Unknown

STOP - VARIABLES 18 THROUGH 20 ARE COMPLETED BY THE ZONE CENTER

RECONSTRUCTION DATA

18. Impact Speed + 999
Nearest kmph

(NOTE: 000 means greater than .5 kmph)
(160) 159.5 kmph and above
(999) Unknown

19. Accuracy Range of Impact Speed Estimate 9
(0) No reconstruction
(1) Less than 2 kmph
(2) >= 2 kmph and <= 8 kmph
(3) >= 9 kmph and <= 16 kmph
(4) >= 17 kmph and <= 26 kmph
(9) Unknown
SPEED, PLEASE!

20. Data Source of Impact Speed C
(0) No impact speed calculated
(1) Zone center calculation
(2) Police calculation
(3) Driver/witness/police estimates

PRECRASH DATA

21. Driver's Attention to Driving 9
(Prior to Recognition of Critical Event)
(1) Full attention to driving
(2) Distracted by other occupant
(3) Distracted by moving object in vehicle
(4) Distracted by outside person, object, or event
(5) Talking on cellular phone or CB radio
Specify:
(6) Sleeping or dozing while driving
(8) Other (specify):
(9) Unknown

22. Pre-Event Vehicle Movement *10 03
(Prior to Recognition of Critical Event)
(01) Going straight
(02) Slowing or stopping in traffic lane
(03) Starting in traffic lane
(04) Stopped in traffic lane
(05) Passing or overtaking another vehicle
(06) Disabled or parked in travel lane
(07) Leaving a parking position
(08) Entering a parking position
(09) Turning right
(10) Turning left
(11) Making a U-turn
(12) Backing up (other than for parking position)
(13) Negotiating a curve
(14) Changing lanes
(15) Merging
(16) Successful avoidance maneuver to a previous critical event
(97) Other (specify):
(98) No driver present
(99) Unknown

*preparing to turn left....

23. Critical Precrash Event 8 /*This Vehicle Loss of Control Due To:*

- (01) Blow out or flat tire
- (02) Stalled engine
- (03) Disabling vehicle failure (e.g., wheel fell off) (specify): _____
- (04) Non-disabling vehicle problem (e.g., hood flew up) (specify): _____
- (05) Poor road conditions (puddle, pot hole, ice, etc.) (specify): _____
- (06) Traveling too fast for conditions
- (08) Other cause of control loss (specify): _____

- (09) Unknown cause of control loss

This Vehicle Traveling

- (10) Over the lane line on left side of travel lane
- (11) Over the lane line on right side of travel lane
- (12) Off the edge of the road on the left side
- (13) Off the edge of the road on the right side
- (14) End departure
- (15) Turning left at intersection
- (16) Turning right at intersection
- (17) Crossing over (passing through) intersection
- (19) Unknown travel direction

Other Motor Vehicle In Lane

- (50) Stopped
- (51) Traveling in same direction with lower speed (i.e., lower steady speed or decelerating)
- (52) Traveling in same direction with higher speed
- (53) Traveling in opposite direction
- (54) In crossover
- (55) Backing
- (59) Unknown travel direction of other motor vehicle in lane

Other Motor Vehicle Encroaching Into Lane

- (60) From adjacent lane (same direction)—over left lane line
- (61) From adjacent lane (same direction)—over right lane line
- (62) From opposite direction—over left lane line
- (63) From opposite direction—over right lane line
- (64) From parking lane
- (65) From crossing street, turning into same direction
- (66) From crossing street, across path
- (67) From crossing street, turning into opposite direction
- (68) From crossing street, intended path not known
- (70) From driveway, turning into same direction
- (71) From driveway, across path
- (72) From driveway, turning into opposite direction
- (73) From driveway, intended path not known
- (74) From entrance to limited access highway
- (78) Encroachment by other vehicle—details unknown

Pedestrian or Pedalcyclist, or Other Nonmotorist

- (80) Pedestrian in roadway
- (81) Pedestrian approaching roadway
- (82) Pedestrian—unknown location

- (83) Pedalcyclist or other nonmotorist in roadway (specify): _____
- (84) Pedalcyclist or other nonmotorist approaching roadway (specify): _____
- (85) Pedalcyclist or other nonmotorist—unknown location (specify): _____

Object or Animal

- (87) Animal in roadway
- (88) Animal approaching roadway
- (89) Animal—unknown location
- (90) Object in roadway
- (91) Object approaching roadway
- (92) Object—unknown location
- (98) Other critical precrash event (specify): _____

- (99) Unknown

24. Attempted Avoidance Maneuver 99
01

- (00) No driver present
- (01) No avoidance actions
- (02) Braking (no lockup)
- (03) Braking (lockup)
- (04) Braking (lockup unknown)
- (05) Releasing brakes
- (06) Steering left
- (07) Steering right
- (08) Braking and steering left
- (09) Braking and steering right
- (10) Accelerating
- (11) Accelerating and steering left
- (12) Accelerating and steering right
- (98) Other action (specify): _____
- (99) Unknown

25. Precrash Stability After Avoidance Maneuver 1
1

- (0) No driver present
- (1) No avoidance maneuver
- (2) Tracking
- (3) Skidding longitudinally—rotation less than 30 degrees
- (4) Skidding laterally—clockwise rotation
- (5) Skidding laterally—counterclockwise rotation
- (8) Other vehicle loss-of-control (specify): _____
- (9) Precrash stability unknown

26. Precrash Directional Consequences of Avoidance Maneuver (Corrective Action) 1
1

- (0) No driver present
- (1) No avoidance maneuver
- (2) Vehicle stayed in travel lane where avoidance maneuver was initiated
- (3) Vehicle stayed on roadway but left travel lane where avoidance maneuver was initiated
- (4) Vehicle stayed on roadway, not known if left travel lane where avoidance maneuver was initiated
- (5) Vehicle departed roadway
- (6) Avoidance maneuver initiated off roadway
- (9) Directional consequences unknown

ENVIRONMENTAL DATA

- | | |
|---|--|
| <p>27. Relation to Junction <u>2</u></p> <p>(0) Non-junction (1) Interchange area</p> <p><i>Non-Interchange</i></p> <p>(2) Intersection (3) Intersection-related (4) Drive, alley access related (5) Other non-interchange (specify): _____</p> <p>(6) _____ type of non-interchange (9) Unknown if interchange</p> | <p>33. Roadway Surface Condition <u>2</u></p> <p>(1) Dry (2) Wet (3) Snow and slush (4) Ice (5) Sand, dirt or oil (8) Other (specify): _____ (9) Unknown</p> |
| <p>28. Trafficway Flow <u>4</u></p> <p>(1) Not physically divided (two way traffic) (2) Divided trafficway - median strip without positive barrier (3) Divided trafficway - median strip with positive barrier (4) One way trafficway (9) Unknown</p> | <p>34. Traffic Control Device <u>1</u></p> <p>(0) No traffic control(s) (1) Trafficway traffic control signal (not RR crossing)</p> <p><i>Regulatory or School Zone Sign (Not RR Crossing)</i></p> <p>(2) Stop sign (3) Yield sign (4) School zone sign (5) Other sign (specify): _____</p> <p>(6) _____ sign (7) Warning sign (not RR crossing) (8) Miscellaneous/other controls including RR controls (specify): _____ (9) Unknown</p> |
| <p>29. Number of Travel Lanes <u>2</u></p> <p>(1) One (2) Two (3) Three (4) Four (5) Five (6) Six (7) Seven or more (9) Unknown</p> | <p>35. Traffic Control Device Functioning <u>2</u></p> <p>(0) No traffic control (1) Not Functioning (2) Functioning (9) Unknown</p> |
| <p>30. Roadway Alignment <u>1</u></p> <p>(1) Straight (2) Curve right (3) Curve left (9) Unknown</p> | <p>36. Light Conditions <u>1</u></p> <p>(1) Daylight (2) Dark (3) Dark, but lighted (4) Dawn (5) Dusk (9) Unknown</p> |
| <p>31. Roadway Profile <u>1</u></p> <p>(1) Level (2) Uphill Grade (>2%) (3) Downhill Grade (>2%) (4) Hillcrest (5) Sag (9) Unknown</p> | <p>37. Atmospheric Conditions <u>1</u></p> <p>(1) No adverse atmospheric related driving conditions (2) Rain (3) Sleet (4) Snow (5) Fog (6) Rain and fog (7) Sleet and fog (8) Other (e.g., smog, smoke, blowing sand or dust, etc.) (specify): _____ (9) Unknown</p> |
| <p>32. Roadway Surface Type <u>2</u></p> <p>(1) Concrete (2) Bituminous (asphalt) (3) Brick or Block (4) Slag, gravel or stone (5) Dirt (8) Other (specify): _____ (9) Unknown</p> | |



1. Primary Sampling Unit Number 40
2. Case Number - Stratum 6 08 P
BN

3. Vehicle Number 01

VEHICLE IDENTIFICATION

VIN JHMBA4216LC [REDACTED] Model Year 90

Vehicle Make (specify): Honda Vehicle Model (specify): Prelude 2.0S

PEDESTRIAN FRONT CONTACT WORK SHEET

N/A - side impact

PEV06 Hood Material _____
PEV08 Hood Length _____ cm
PEV09 Hood Width-Forward Opening _____ cm
PEV10 Hood Width-Midway _____ cm
PEV11 Hood Width-Rear Opening _____ cm
PEV14 Front Bumper Cover Material _____
PEV15 Front Bumper Reinforcement Material _____

VERTICAL MEASUREMENTS

PEV16 Front Bumper-Bottom Height _____ cm
PEV17 Front Bumper-Top Height _____ cm
PEV18 Forward Hood Opening _____ cm
PEV19 Front Bumper Lead _____ cm

WRAP DISTANCES

PEV20 Ground to Forward Hood Opening _____ cm
PEV21 Ground to Front/Top Transition Point _____ cm
PEV22 Ground to Rear Hood Opening _____ cm
PEV23 Ground to Base of Windshield _____ cm
PEV24 Ground to Top of Windshield _____ cm
PEV25 Ground to Head Contact _____ cm

VEHICLE DAMAGE SKETCH

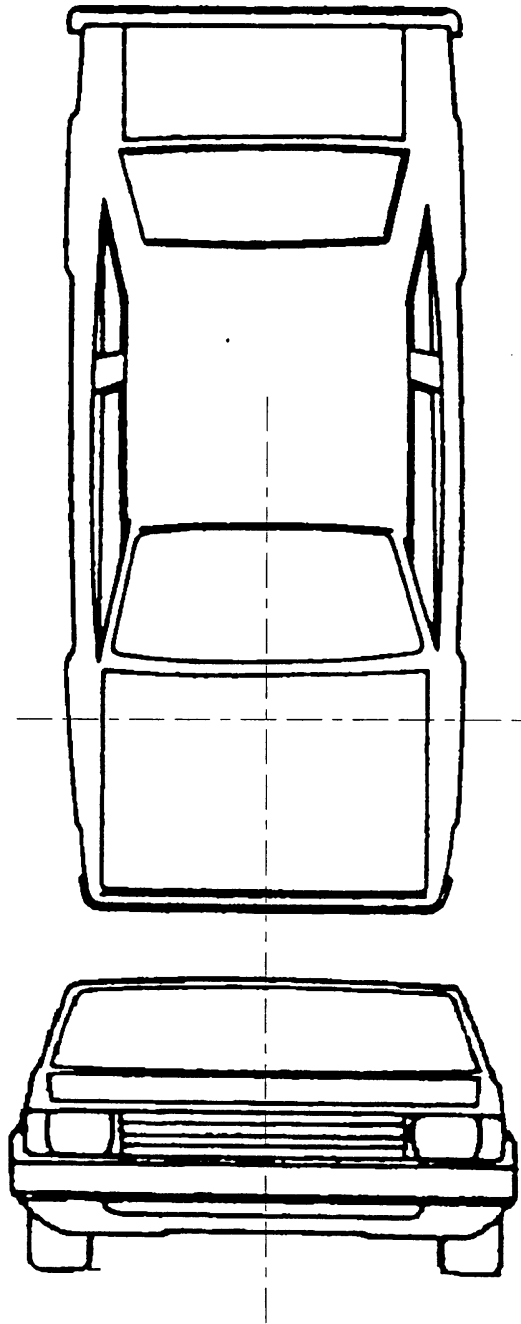

NOTES: Sketch all pedestrian contacts, include the size and depth in centimeters. Locate the pedestrian contacts from the intercept point of the centerline (lateral) and the front axles (longitudinal) in centimeters. Annotate observations which might be useful in reconstructing the accident (e.g., grass in tire bead, direction of striations, scuff on sidewalls, etc.).

Location of the origin (intercept point of the centerline and the front axles) from the ground: _____ cm

PEDESTRIAN SIDE CONTACT WORK SHEET

| | | |
|----------------------------------|--------------|----|
| PEV06 Hood Material | <u>STEEL</u> | |
| PEV08 Hood Length | <u>116</u> | cm |
| PEV09 Hood Width-Forward Opening | <u>138</u> | cm |
| PEV10 Hood Width-Midway | <u>144</u> | cm |
| PEV11 Hood Width-Rear Opening | <u>148</u> | cm |

VERTICAL MEASUREMENTS

| | | |
|--|------------|----|
| PEV26 Ground Clearance | <u>23</u> | cm |
| PEV27 Side Bumper-Bottom Height | <u>35</u> | cm |
| PEV28 Side Bumper-Top Height | <u>82</u> | cm |
| PEV29 Centerline of Wheel | <u>27</u> | cm |
| PEV30 Top of Tire | <u>57</u> | cm |
| PEV31 Top of Wheel Well Opening | <u>67</u> | cm |
| PEV32 Bottom of A-Pillar at Windshield | <u>83</u> | cm |
| PEV33 Top of A-Pillar at Windshield | <u>119</u> | cm |
| PEV34 Top of Side View Mirror | <u>96</u> | cm |

LATERAL MEASUREMENTS

| | | |
|---|-----------|----|
| PEV35 C _L to A-Pillar at Bottom of Windshield | <u>77</u> | cm |
| PEV36 C _L to A-Pillar at Top of Windshield | <u>59</u> | cm |
| PEV37 C _L to Maximum Side View Mirror Protrusion | <u>95</u> | cm |

WRAP DISTANCES

| | | |
|---|----------------|----|
| PEV38 Ground to Side/Top Transition | <u>28</u> | cm |
| PEV39 Ground to Hood Edge | <u>83</u> | cm |
| PEV40 Ground to Centerline of Hood (ORIGIN) | <u>83 + 70</u> | cm |
| PEV41 Ground to Head Contact | <u>299</u> | cm |

ORIGINAL SPECIFICATIONS

| | | | | |
|--------------------------|--------------|--------|-----------|----------------|
| Wheelbase | <u>101.2</u> | inches | x 2.54 = | <u>257</u> cm |
| Overall Length | <u>177.6</u> | inches | x 2.54 = | <u>451</u> cm |
| Maximum Width | <u>67.3</u> | inches | x 2.54 = | <u>171</u> cm |
| Curb Weight | <u>2633</u> | pounds | x .4536 = | <u>1197</u> kg |
| Average Track | <u>58.1</u> | inches | x 2.54 = | <u>148</u> cm |
| Front Overhang | <u> </u> | inches | x 2.54 = | <u> </u> cm |
| Rear Overhang | <u> </u> | inches | x 2.54 = | <u> </u> cm |
| Undeformed End Width | <u>60.6</u> | inches | x 2.54 = | <u>154</u> cm |
| Engine Size: cyl./displ. | <u> </u> | cc | x .001 = | <u>2.0</u> L |
| | <u> </u> | CID | x .0164 = | <u> </u> L |

INJURY SOURCE

FRONT

- 700 Front bumper
- 701 Front lower valance/spoiler
- 702 Front grille
- 703 Hood edge and/or trim
- 704 Hood ornament (fixed)
- 705 Hood ornament (spring loaded)
- 706 Headlight
- 707 Retractable headlight door (Open/Closed)
- 708 Turn signal/parking lights
- 718 Other front or add on object
(specify): _____
- 719 Unknown front object

Left Side Components

- 720 Front fender side surface
- 721 Front antenna
- 722 A1 pillar
- 723 A2 pillar
- 724 B pillar
- 725 C pillar
- 726 D pillar
- 728 Other pillar
(specify): _____
- 729 Left side roof rail
- 730 Left side door surface
- 731 Left side door handle
- 732 Left side mirror fixed housing
- 733 Left side folding mirror
- 734 Left side glazing forward of B pillar
- 735 Left side glazing rearward of B pillar
- 736 Left side back fender or quarter panel
- 737 Rear antenna
- 738 Other left side object
(specify): _____
- 739 Unknown left side component

Right Side Components

- 740 Front fender side surface
- 741 Front antenna
- 742 A1 pillar
- 743 A2 pillar

- 744 B pillar
- 745 C pillar
- 746 D pillar
- 748 Other pillar (specify): _____
- 749 Right side roof rail
- 750 Right side door surface
- 751 Right side door handle
- 752 Right side mirror fixed housing
- 753 Right side folding mirror
- 754 Right side glazing forward of B pillar
- 755 Right side glazing rearward of B pillar
- 756 Rear antenna
- 757 Rear fender or quarter panel
- 758 Other right side object
(specify): _____
- 759 Unknown right side component

Back Components

- 760 Rear (back) bumper
- 761 Tailgate
- 762 Hatchback, vertical surface
- 768 Other back component
(specify): _____
- 769 Unknown back component

Top Components

- 770 Hood surface
- 771 Hood surface reinforced by under hood component
- 772 Front fender top surface
- 773 Cowl area
- 774 Wiper blade & mountings
- 775 Windshield glazing
- 776 Front header
- 777 Roof surface
- 778 Backlight glazing
- 779 Rear header
- 780 Hatchback
- 781 Rear trunk lid
- 788 Other top component (specify): _____
- 789 Unknown top component

Wheels / tires

- 790 Left front wheel / tire
- 791 Right front wheel / tire
- 792 Left rear wheel / tire
- 793 Right rear wheel / tire
- 798 Other wheel / tire (specify): _____
- 799 Unknown wheel / tire

Undercarriage components

- 800 Front cross member
- 801 Steering assembly/Front suspension
- 802 Oil pan
- 803 Exhaust system pipe
- 804 Transmission
- 805 Drive shaft
- 806 Catalytic converter
- 807 Muffler
- 808 Floor pan
- 809 Fuel tank
- 810 Rear suspension
- 818 Other undercarriage component
(specify): _____
- 819 Unknown undercarriage component

Accessories

- 820 Air scoop, deflector
- 821 Cellular or CB radio antenna
- 822 Emergency lights or bar
- 823 Fog lights
- 824 Luggage, ski, or bike rack
- 825 Cargo (specify): _____
- 826 Spare tire
- 827 Spotlight
- 828 Other accessory (specify): _____

Other Object or Vehicle in Environment

- 947 Ground
- 948 Other object (specify): _____
- 949 Unknown object in environment
- 959 Unknown object on contacting vehicle
- 997 Noncontact injury source
- 999 Unknown injury source

VEHICLE DAMAGE SKETCH

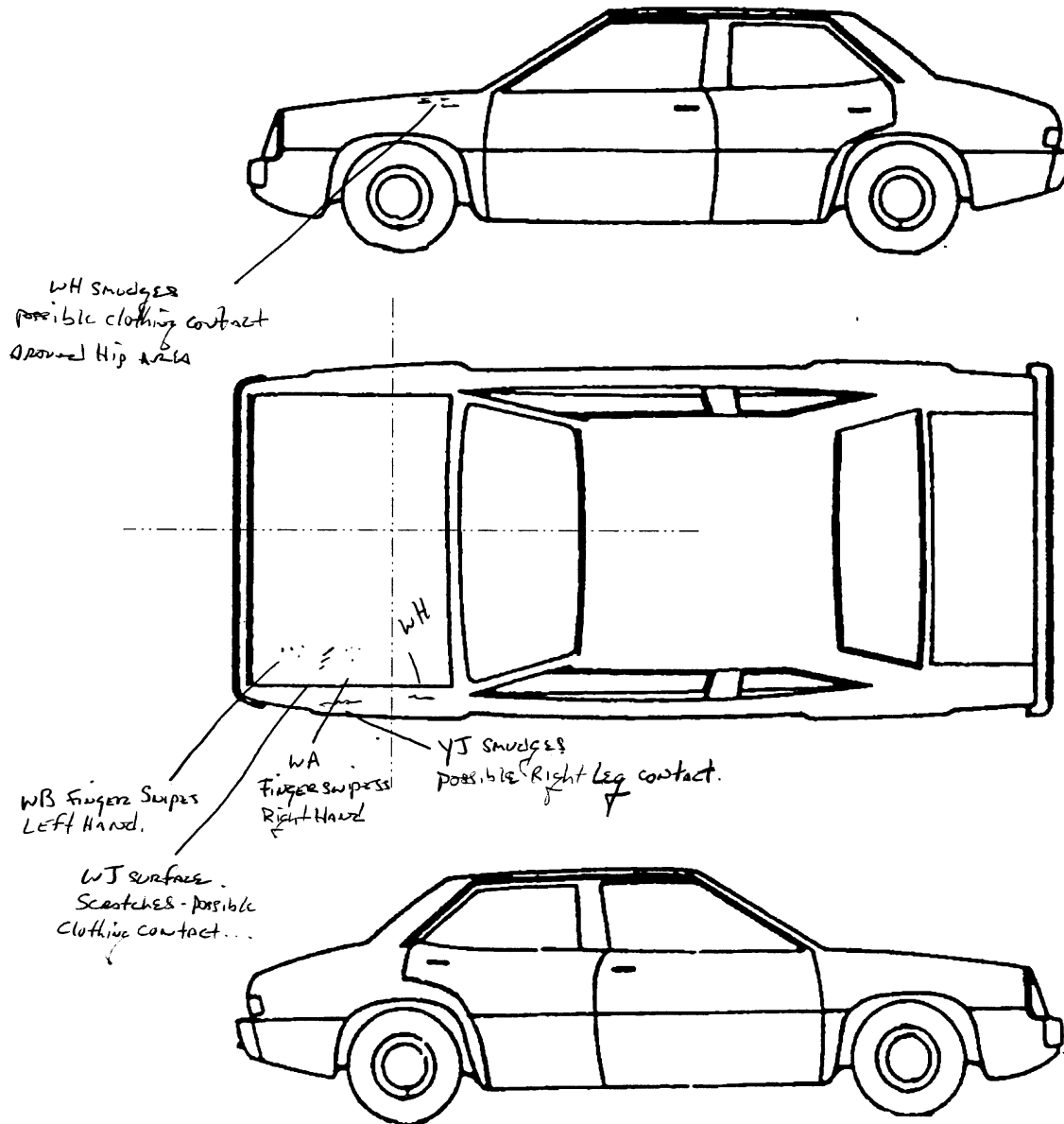

NOTES: Sketch all pedestrian contacts, include the size and depth in centimeters. Locate the pedestrian contacts from the intercept point of the centerline (lateral) and the front axes (longitudinal) in centimeters. Annotate observations which might be useful in reconstructing the accident (e.g., grass in tire bead, direction of striations, scuff on sidewalls, etc.).

Location of the origin (intercept point of the centerline and the front axes) from the ground: 144 cm

VEHICLE DIMENSIONS

4. Original Wheelbase 257
 _____ Code to the
 nearest centimeter
 (999) Unknown

101.2 inches X 2.54 = 257 centimeters

5. Original Average Track Width 148
 _____ Code to the
 nearest centimeter
 (185) 185 centimeters or more
 (999) Unknown

58.1 inches X 2.54 = 148 centimeters

6. Hood Material 9
 (1) Plastic
 (2) Fiberglass
 (3) Steel
 (4) Aluminum
 (5) Stainless Steel
 (8) Other (specify): _____
 (9) Unknown

7. Hood Original 1
 Equipment Manufacturer (OEM)
 (1) OEM factory installed hood
 (2) OEM replacement
 (3) Non-OEM replacement
 (9) Unknown

8. Hood Length 116
 _____ Code to the
 nearest centimeter
 (180) 180 centimeters or more
 (999) Unknown

_____ inches X 2.54 = 116 centimeter

9. Hood Width Forward Opening 138
 _____ Code to the
 nearest centimeter
 (210) 210 centimeters or more
 (999) Unknown

_____ inches X 2.54 = 138 centimeters

10. Hood Width Midway 144
 _____ Code to the
 nearest centimeter
 (210) 210 centimeters or more
 (999) Unknown

_____ inches X 2.54 = 144 centimeters

11. Hood Width Rear Opening 148
 _____ Code to the
 nearest centimeter
 (210) 210 centimeters or more
 (999) Unknown

_____ inches X 2.54 = 148 centimeters

12. Hood/Fender Vertical/Lateral Crush From Pedestrian 1
 (0) Not damaged
 (1) Surface scratching only, no residual crush
 (2) Minor crush (1-3 centimeters)
 (3) Moderate crush (4-7 centimeters)
 (4) Severe crush (>7 centimeters)
 (8) Damage present, unknown if damage is from pedestrian impact
 (9) Unknown

13. Windshield Contact Damage 0
 From Pedestrian Contact
 (0) Not contacted by pedestrian
 (1) Contacted by pedestrian - not damaged
 (2) Contacted by pedestrian - damaged
 (3) Unknown if contacted by pedestrian - not damaged
 (4) Unknown if contacted by pedestrian - damaged
 (9) Unknown if contacted by pedestrian - unknown if damaged

FRONT CONTACT DAMAGE

Front Vertical Measurements

14. Front Bumper Cover Material 0
 (0) No front contact
 (1) Plastic
 (2) Fiberglass
 (3) Rubber
 (4) Other (specify): _____
 (9) Unknown

15. Front Bumper Reinforcement Material 0
 (0) No front contact
 (1) Steel
 (2) Aluminum
 (3) Stainless Steel
 (4) Other (specify): _____
 (9) Unknown

16. Front Bumper-Bottom Height 000
 _____ Code to the
 nearest centimeter
 (000) No front contact
 (150) 150 centimeters or more
 (999) Unknown

_____ inches X 2.54 = _____ centimeters

17. Front Bumper-Top Height 000
 _____ Code to the
 nearest centimeter
 (000) No front contact
 (150) 150 centimeters or more
 (999) Unknown

_____ inches X 2.54 = _____ centimeters

18. Forward Hood Opening 000
 _____ Code to the
 nearest centimeter
 (000) No front contact
 (200) 200 centimeters or more
 (999) Unknown

_____ inches X 2.54 = _____ centimeters

19. Front Bumper Lead 00
 (00) No front contact
 _____ Code to the
 nearest centimeter
 (30) 30 centimeters or more
 (99) Unknown

_____ inches X 2.54 = _____ centimeters

23. Ground to Base of Windshield 000
 _____ Code to the
 nearest centimeter
 (000) No front contact
 (400) 400 centimeters or more
 (999) Unknown

_____ inches X 2.54 = _____ centimeters

24. Ground to Top of Windshield 000
 _____ Code to the
 nearest centimeter
 (000) No front contact
 (500) 500 centimeters or more
 (999) Unknown

_____ inches X 2.54 = _____ centimeters

25. Ground To Head Contact 000
 _____ Code to the
 nearest centimeter
 (000) No front contact
 (400) 400 centimeters or more
 (998) No head contact
 (999) Unknown

_____ inches X 2.54 = _____ centimeters

Front Wrap Distance Measurements

20. Ground to Forward Hood Opening 000
 _____ Code to the
 nearest centimeter
 (000) No front contact
 (200) 200 centimeters or more
 (999) Unknown

_____ inches X 2.54 = _____ centimeters

21. Ground to Front/Top Transition Point 000
 _____ Code to the
 nearest centimeter
 (000) No front contact
 (180) 180 centimeters or more
 (999) Unknown

_____ inches X 2.54 = _____ centimeters

22. Ground to Rear Hood Opening 000
 _____ Code to the
 nearest centimeter
 (000) No front contact
 (400) 400 centimeters or more
 (999) Unknown

_____ inches X 2.54 = _____ centimeters

SIDE CONTACT DAMAGE

Side Vertical Measurements

26. Ground Clearance 023
 _____ Code to the
 nearest centimeter
 (000) No side contact
 (150) 150 centimeters or more
 (999) Unknown

9.1 inches X 2.54 = 23 centimeters

27. Side Bumper-Bottom Height 035
 _____ Code to the
 nearest centimeter
 (000) No side contact
 (150) 150 centimeters or more
 (999) Unknown

13.8 inches X 2.54 = 35 centimeters

28. Side Bumper-Top Height 052
 _____ Code to the
 nearest centimeter
 (000) No side contact
 (150) 150 centimeters or more
 (999) Unknown

20.5 inches X 2.54 = 52 centimeters

29. Centerline of Wheel 0 2 7
 _____ Code to the
 nearest centimeter
 (000) No side contact
 (150) 150 centimeters or more
 (999) Unknown

10.6 inches X 2.54 = 27 centimeters

30. Top of Tire 0 5 7
 _____ Code to the
 nearest centimeter
 (000) No side contact
 (200) 200 centimeters or more
 (999) Unknown

22.4 inches X 2.54 = 57 centimeters

31. Top of Wheel Well Opening 0 6 7
 _____ Code to the
 nearest centimeter
 (000) No side contact
 (250) 250 centimeters or more
 (999) Unknown

26.4 inches X 2.54 = 67 centimeters

32. Bottom of A-Pillar at Windshield 0 8 3
 _____ Code to the
 nearest centimeter
 (000) No side contact
 (250) 250 centimeters or more
 (999) Unknown

32.7 inches X 2.54 = 083 centimeters

33. Top of A-Pillar at Windshield 1 1 9
 _____ Code to the
 nearest centimeter
 (000) No side contact
 (300) 300 centimeters or more
 (999) Unknown

46.9 inches X 2.54 = 119 centimeters

34. Top of Side View Mirror 0 9 6
 _____ Code to the
 nearest centimeter
 (000) No side contact
 (300) 300 centimeters or more
 (999) Unknown

37.8 inches X 2.54 = 96 centimeters

Side Lateral Measurements

35. Centerline to A-Pillar 0 7 7
 at Bottom of Windshield
 (000) No side contact
 _____ Code to the
 nearest centimeter
 (250) 250 centimeters or more
 (999) Unknown

30.3 inches X 2.54 = 77 centimeters

36. Centerline to A-Pillar 0 5 9
 at Top of Windshield
 _____ Code to the
 nearest centimeter
 (000) No side contact
 (250) 250 centimeters or more
 (999) Unknown

23.2 inches X 2.54 = 59 centimeter

37. Centerline to Maximum Side 0 9 5
 View Mirror Protrusion
 _____ Code to the
 nearest centimeter
 (000) No side contact
 (300) 300 centimeters or more
 (999) Unknown

32.7 inches X 2.54 = 95 centimeter

Side Wrap Distance Measurements

38. Ground to Side/Top Transition 0 7 8
 _____ Code to the
 nearest centimeter
 (000) No side contact
 (400) 400 centimeters or more
 (999) Unknown

30.7 inches X 2.54 = 78 centimeters

39. Ground to Hood Edge 0 8 3
 _____ Code to the
 nearest centimeter
 (000) No side contact
 (500) 500 centimeters or more
 (999) Unknown

32.7 inches X 2.54 = 83 centimeters

40. Ground to Centerline of Hood 153 Code to the
nearest centimeter

(000) No side contact

(700) 700 centimeters or more

(999) Unknown

 60 . 2 inches X 2.54 = 153 centimeters41. Ground to Head Contact 998 Code to the
nearest centimeter

(000) No side contact

(800) 800 centimeters or more

(998) No head contact

(999) Unknown

 . inches X 2.54 = centimeters

MDE Date [REDACTED] 96

UPDATE [REDACTED] 96

1

PSU40
CASE 608P

1996 PEDESTRIAN ACCIDENT FORM

IDENTIFICATION

3. Number of General Vehicle Forms Submitted 01
4. Date of Accident (Month, Day, Year) [REDACTED]/96
5. Time of Accident (military time) 1540

SPECIAL STUDIES - INDICATORS

6. SS15 0 7. SS16 1 8. SS17 0 9. SS18 0 10. SS19 0

NUMBER OF EVENTS

11. Number of Recorded Events in This Accident 01
01

PSU40
CASE 608P

1996 PEDESTRIAN ACCIDENT FORM

PEDESTRIAN ACCIDENT EVENTS

| Accident Sequence Number | Vehicle Number | Class of Vehicle | General Area of Damage | Veh. Num. or Obj. Cont. | Class of Vehicle | General Area of Damage |
|--------------------------------|-------------------|---------------------|------------------------------|-------------------------------|---------------------|------------------------------|
| 12. 01 | 13. 01 | 14. 02 | 15. L | 16. 72 | 17. 00 | 18. 0 |

01

PEDESTRIAN'S CHARACTERISTICS

| | |
|---|-----|
| 4. Pedestrian's Age | 22 |
| 5. Pedestrian's Sex | 2 |
| 6. Pedestrian's Overall Height | 999 |
| 7. Pedestrian's Height - Ground to Knee | 99 |
| 8. Pedestrian's Height - Ground to Hip | 999 |
| 9. Pedestrian's Height - Ground to Shoulder | 999 |
| 10. Pedestrian's Weight | 999 |

PEDESTRIAN'S PRE-AVOIDANCE ACTIONS

| | |
|---|----|
| 11. Pedestrian's Attitude | 1 |
| 12. Pedestrian's Motion | 9 |
| 13. Pedestrian's Actions Relative to Vehicle | 01 |
| 14. Pedestrian's Body (Chest) Orientation Relative to Striking Vehicle Prior to Avoidance Actions | 4 |

PEDESTRIAN'S AVOIDANCE ACTIONS

| | |
|--|----|
| 15. Pedestrian's First Avoidance Actions | 13 |
|--|----|

PEDESTRIAN'S ORIENTATION AT IMPACT

| | |
|---|----|
| 16. Pedestrian's Head Orientation at Initial Impact | 9 |
| 17. Pedestrian's Body (Chest) Orientation at Initial Impact | 4 |
| 18. Pedestrian's Arm Orientation at Initial Impact | 99 |
| 19. Pedestrian's Leg Orientation at Initial Impact | 99 |
| 20. Vehicle/Pedestrian's Interaction | 14 |

OFFICIAL RECORDS

| | |
|--|----|
| 21. Police Reported Alcohol Presence For Pedestrian | 0 |
| 22. Alcohol Test Result For Pedestrian | 96 |
| 23. Police Reported Other Drug Presence For Pedestrian | 0 |
| 24. Other Drug Specimen Test Result For Pedestrian | 0 |

INJURY CONSEQUENCES

| | |
|--|----|
| 25. Injury Severity (Police Rating) | 1 |
| 26. Treatment - Mortality | 4 |
| 27. Type of Medical Facility (for Initial Treatment) | 1 |
| 28. Hospital Stay | 00 |
| 29. Working Days Lost | 99 |

(COMPLETED BY THE ZONE CENTER)

| | |
|---|----|
| 30. Glasgow Coma Scale Score | 15 |
| 31. Was the Pedestrian Given Blood? | 1 |
| 32. Arterial Blood Gases | 01 |
| 33. Time to Death | 00 |
| 34. 1st Medically Reported Cause of Death | 00 |
| 35. 2nd Medically Reported Cause of Death | 00 |
| 36. 3rd Medically Reported Cause of Death | 00 |
| 37. Number of Recorded Injuries for This Pedestrian | 02 |

01

PSU40

1996 PEDESTRIAN INJURY FORM

CASE 608P

VEHICLE 01 PEDESTRIAN 01

PEDESTRIAN INJURY DATA

| | Source of Inj. Data | Body Reg. | Type of Anat. Struc. | Spec. Anat. Struc. | Lev. of Inj. | AIS Sev. | Asp. | Inj. Source | Inj. Source Conf. Level | Dir./ Indir. Inj. | Str. Pro. | Type of Dmg. | Dmg. Dep. |
|-----|------------------------------|--------------|-------------------------------|--------------------------|--------------------|-------------|------|----------------|----------------------------------|-------------------------|--------------|--------------------|--------------|
| 01. | 3 | 6 | 4 | 06 | 78 | 1 | 8 | 997 | 2 | 3 | 0 | 0 | 0 |
| 02. | 3 | 8 | 9 | 04 | 02 | 1 | 1 | 720 | 1 | 1 | 4 | 2 | 2 |

01

PSU40
CASE 608P
VEHICLE 01

1996 PEDESTRIAN GENERAL VEHICLE FORM

VEHICLE IDENTIFICATION

| | |
|----------------------------------|------------------------|
| 4. Vehicle Model Year | 90 |
| 5. Vehicle Make | 37 |
| 6. Vehicle Model | 033 |
| 7. Body Type | 02 |
| 8. Vehicle Identification Number | JHMBA4216LC [REDACTED] |

OFFICIAL RECORDS

| | |
|---|-----|
| 9. Police Reported Travel Speed | 999 |
| 10. Speed Limit | 048 |
| 11. Police Reported Alcohol Presence For Driver | 0 |
| 12. Alcohol Test Result For Driver | 96 |
| 13. Police Reported Other Drug Presence | 0 |
| 14. Other Drug Specimen Test Result for Driver | 0 |

VEHICLE WEIGHT ITEMS

| | |
|--------------------------|-------|
| 15. Vehicle Curb Weight | 1,200 |
| 16. Vehicle Cargo Weight | 9,990 |

OTHER DATA

| | |
|-------------------------------------|---|
| 17. Vehicle Special Use (This Trip) | 0 |
|-------------------------------------|---|

RECONSTRUCTION DATA (COMPLETED BY THE ZONE CENTER)

| | |
|---|------|
| 18. Impact Speed | +999 |
| 19. Accuracy Range of Impact Speed Estimate | 9 |
| 20. Data Source of Impact Speed | 0 |

PRECRASH DATA

| | |
|-----------------------------------|----|
| 21. Driver's Attention to Driving | 9 |
| 22. Pre-Event Vehicle Movement | 03 |

PRECRASH DATA (continued)

| | |
|---|----|
| 23. Critical Precrash Event | 81 |
| 24. Attempted Avoidance Maneuver | 01 |
| 25. Precrash Stability After Avoidance Maneuver | 1 |
| 26. Precrash Directional Consequences of Avoidance Manuver (Corrective Action) | 1 |

ENVIRONMENTAL DATA

| | |
|--|---|
| 27. Relation to Junction | 2 |
| 28. Trafficway Flow | 4 |
| 29. Number of Travel Lanes | 2 |
| 30. Roadway Alignment | 1 |
| 31. Roadway Profile | 1 |
| 32. Roadway Surface Type | 2 |
| 33. Roadway Surface Condition | 2 |
| 34. Traffic Control Device | 1 |
| 35. Traffic Control Device Functioning | 2 |
| 36. Light Conditions | 1 |
| 37. Atmospheric Conditions | 1 |

01

VEHICLE DIMENSIONS

| | |
|---|-----|
| 4. Original Wheelbase | 257 |
| 5. Original Average Track Width | 148 |
| 6. Hood Material | 9 |
| 7. Hood Original Equip. Manufacturer | 1 |
| 8. Hood Length | 116 |
| 9. Hood Width Forward Opening | 138 |
| 10. Hood Width Midway | 144 |
| 11. Hood Width Rear Opening | 148 |
| 12. Hood/Fender Vertical/Lateral Crush From Pedestrian | 1 |
| 13. Windshield Contact Damage From Pedestrian Contact | 0 |

FRONT CONTACT DAMAGE

FRONT VERTICAL MEASUREMENTS

| | | | |
|---------------------------------|-----|-------------------------------------|-----|
| 14. Front Bumper Cover Material | 0 | 15. Front Bumper Reinforcement Mat. | 0 |
| 16. Front Bumper-Bottom Height | 000 | 17. Front Bumper-Top Height | 000 |
| 18. Forward Hood Opening | 000 | 19. Front Bumper Lead | 00 |

FRONT WRAP DISTANCE MEASUREMENTS

| | | | |
|---------------------------------|-----|---------------------------------------|-----|
| 20. Ground to Fwd. Hood Opening | 000 | 21. Ground to Front/Top Transition Pt | 000 |
| 22. Ground to Rear Hood Opening | 000 | 23. Ground to Base of Windshield | 000 |
| 24. Ground to Top of Windshield | 000 | 25. Ground to Head Contact | 000 |

SIDE CONTACT DAMAGE

SIDE VERTICAL MEASUREMENTS

| | |
|--------------------------------------|-----|
| 26. Ground Clearance | 023 |
| 27. Side Bumper-Bottom Height | 035 |
| 28. Side Bumper-Top Height | 052 |
| 29. Centerline of Wheel | 027 |
| 30. Top of Tire | 057 |
| 31. Top of Wheel Well Opening | 067 |
| 32. Bottom of A-Pillar at Windshield | 083 |
| 33. Top of A-Pillar at Windshield | 119 |
| 34. Top of Side View Mirror | 096 |

SIDE CONTACT DAMAGE (continued)

SIDE LATERAL MEASUREMENTS

| | |
|---|-----|
| 35. Centerline to A-Pillar at Bottom of Windshield | 077 |
| 36. Centerline to A-Pillar at Top of Windshield | 059 |
| 37. Centerline to Maximum Side View Mirror Protrusion | 095 |

SIDE WRAP DISTANCE MEASUREMENTS

| | |
|---|-----|
| 38. Ground to Side/Top Transition | 078 |
| 39. Ground to Hood Edge | 083 |
| 40. Ground to Centerline of Hood (Origin) | 153 |
| 41. Ground to Head Contact | 998 |

0

PSU40
CASE 608P
CURRENT VERSION: 9.00

ERROR SUMMARY SCREEN
PEDESTRIAN STUDY

██████/96

| FORM NAME | NUMBER OF DOLLAR SIGNS | NUMBER OF LEVEL 1 ERRORS | NUMBER OF LEVEL 2 ERRORS | VERSION NUMBER CONSISTENT |
|-----------------------------|---------------------------|--------------------------------|--------------------------------|---------------------------------|
| Pedestrian Accident | 0 | 0 | 0 | Y |
| Pedestrian Assessment | 0 | 0 | 0 | Y |
| Pedestrian Injury | 0 | 0 | 0 | Y |
| Pedestrian General Vehicle | 0 | 0 | 0 | Y |
| Pedestrian Exterior Vehicle | 0 | 0 | 0 | Y |
| Total Inter Errors | | 0 | 0 | |
| Total Case Errors | 0 | 0 | 0 | |