

TP-110P-04
September 28, 2012

U.S. DEPARTMENT OF TRANSPORTATION
NATIONAL HIGHWAY TRAFFIC SAFETY ADMINISTRATION
LABORATORY TEST PROCEDURE

FOR

FMVSS 110

Tire Selection and Rims and Motor Home/Recreation
Vehicle Trailer Load Carrying Capacity Information for
Motor Vehicles With a GVWR of
4,536 Kilograms (10,000 Pounds) or Less
(For Passenger Car Tests Only)

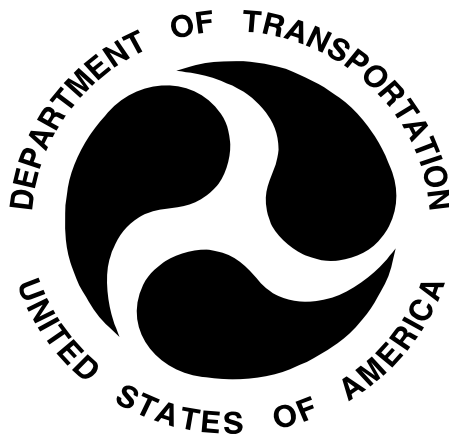

ENFORCEMENT
Office of Vehicle Safety Compliance
Mail Code: NVS-220
1200 New Jersey Ave, SE
Washington, DC 20590

OVSC LABORATORY TEST PROCEDURE NO. 110
TABLE OF CONTENTS

	PAGE
1. PURPOSE AND APPLICATION.....	1
2. GENERAL REQUIREMENTS.....	2
3. SECURITY	3
4. GOOD HOUSEKEEPING	4
5. TEST SCHEDULING AND MONITORING	4
6. TEST DATA DISPOSITION.....	4
7. GOVERNMENT FURNISHED PROPERTY (GFP).....	6
8. CALIBRATION OF TEST INSTRUMENTS.....	8
9. SUGGESTED TEST EQUIPMENT	10
10. PHOTOGRAPHIC DOCUMENTATION	11
11. DEFINITIONS.....	12
12. PRETEST REQUIREMENTS	14
13. COMPLIANCE TEST EXECUTION.....	15
14. POST TEST REQUIREMENTS.....	21
15. REPORTS	22
15.1 MONTHLY STATUS REPORTS.....	22
15.2 APPARENT TEST FAILURE	22
15.3 FINAL TEST REPORTS	22
15.3.1 COPIES	22
15.3.2 REQUIREMENTS	23
15.3.3 FIRST THREE PAGES	23
15.3.4 TABLE OF CONTENTS	29
16. DATA SHEETS.....	30
17. FORMS	48

**REVISION CONTROL LOG
FOR OVSC LABORATORY
TEST PROCEDURES**

**TP-110P
TIRE SELECTION AND RIMS
(For Passenger Car Tests Only)**

TEST PROCEDURE		FMVSS 110P		DESCRIPTION
REV. No.	DATE	AMENDMENT	EFFECTIVE DATE	
00	1/5/05	67FR69600 11/18/02	9/1/03	Final Rule
		68FR33655 6/5/03	9/1/04	Final Rule - response in part to petitions for reconsideration. Effective date delayed.
		68FR37981 6/26/03	9/1/04	Final Rule – correcting amendment.
		69FR31306 6/3/04	9/1/05	Final Rule - response to petitions for reconsideration.
		69FR51399 8/19/04	9/1/05	Correcting Amendment.
01	12/13/05	70FR14420 3/22/05	9/1/05	Final Rule – response to petitions for reconsideration – technical amendment.
02	1/10/06	71FR877 1/6/06	9/1/07	Final Rule – response to petitions for reconsideration. (Revised TP vehicle applicability dates on Page 2.)
03	8/14/07	71FR877 1/6/06	9/1/07	Final Rule – response to petitions for reconsideration. Certain performance requirements effective on 9/1/07.
04	09/28/12	72FR68442 12/4/07	6/2/08	Final Rule – Cargo Carrying Capacity Modification Label Miscellaneous format changes made to adopt a standardized format for the OVSC test procedures. ¹
05				

¹ The Office of Vehicle Safety Compliance is updating its laboratory test procedures, to the extent practicable, with a standardized format.

1. PURPOSE AND APPLICATION

This document is a laboratory test procedure provided by the National Highway Traffic Safety Administration (NHTSA), Office of Vehicle Safety Compliance (OVSC) for the purpose of presenting guidelines for a uniform testing data and information recording format, and providing suggestions for the use of specific equipment and procedures for contracted testing laboratories. The data correspond to specific requirements of the Federal Motor Vehicle Safety Standard(s) (FMVSS). The OVSC test procedures include requirements that are general in scope to provide flexibility for contracted laboratories to perform compliance testing and are not intended to limit or restrain a contractor from developing or utilizing any testing techniques or equipment which will assist in procuring the required compliance test data. These test procedures do not constitute an endorsement or recommendation for use of any particular product or testing method.

Prior to conducting compliance testing, contracted laboratories are required to submit a detailed test procedure to the Contracting Officer's Technical Representative (COTR) to demonstrate concurrence with the OVSC laboratory test procedure and the applicable FMVSS. If any contractor views any part of an OVSC laboratory test procedure to be in conflict with a FMVSS or observes deficiencies in a laboratory test procedure, the contractor is required to advise the COTR and resolve the discrepancy prior to the start of compliance testing or as soon as practicable. The contractor's test procedure must include a step-by-step description of the methodology and detailed check-off sheets. Detailed check-off sheets shall also be provided for the testing instrumentation including a complete listing of the test equipment with make and model numbers. The list of test equipment shall include instrument accuracy and calibration dates. All equipment shall be calibrated in accordance with the manufacturer's instructions. There shall be no contradictions between the laboratory test procedure and the contractor's in-house test procedure. Written approval of the in-house test procedures shall be obtained from the COTR before initiating the compliance test program.

NOTE: The OVSC Laboratory Test Procedures, prepared for the limited purpose of use by independent laboratories under contract to conduct compliance tests for the OVSC, are not rules, regulations or NHTSA interpretations regarding the meaning of a FMVSS. The laboratory test procedures are not intended to limit the requirements of the applicable FMVSS(s). In some cases, the OVSC laboratory test procedures do not include all of the various FMVSS minimum performance requirements. Recognizing applicable test tolerances, the laboratory test procedures may specify test conditions that are less severe than the minimum requirements of the standard. In addition, the laboratory test procedures may be modified by the OVSC at any time without notice, and the COTR may direct or authorize contractors to deviate

1. PURPOSE AND APPLICATION....Continued

from these procedures, as long as the tests are performed in a manner consistent with the standard itself and within the scope of the contract. Laboratory test procedures may not be relied upon to create any right or benefit in any person. Therefore, compliance of a vehicle or item of motor vehicle equipment is not necessarily guaranteed if the manufacturer limits its certification tests to those described in the OVSC laboratory test procedures.

2. GENERAL REQUIREMENTS

This Test Procedure applies only to Passenger Cars.

Passenger cars are to be equipped with tires that meet the requirements of FMVSS 139, New Pneumatic Radial Tires for Light Vehicles, except that passenger cars may be equipped with a pneumatic T-type temporary spare tire that meets the requirements of FMVSS 109, or a non-pneumatic spare tire assembly that meets the requirements of FMVSS 129, New Non-Pneumatic Tires for Passenger Cars.

The vehicle maximum load on the tire is not to be greater than the applicable maximum load rating as marked on the sidewall of the tire.

The vehicle normal load on the tire is not to be greater than the value of 94 percent of the load rating at the vehicle manufacturer's recommended cold inflation pressure for that tire.

A single vehicle placard or a vehicle placard and a supplementary tire inflation pressure label must be affixed to each car.

If the weight exceeding the lesser of 1.5 percent of the GVWR or 45.4 kg (100 pounds) is added to a passenger car between final vehicle certification and first retail sale, the car's capacity weight value on the vehicle placard must be corrected by attaching a load carrying capacity modification label or other method specified.

Each rim is to be constructed according to the dimensions referred to in S4 of FMVSS 139 that is listed by the manufacturer of the tires for use with those tires and is to be capable of retaining a tire after a rapid loss of inflation pressure at 97 kilometers per hour.

49 CFR Part 575 – *Consumer Information Regulations*, sections 575.6(a)(4) and (5) require each vehicle owner's manual or other document to provide discussions or statements relating to vehicle labeling, tires and loading.

2. GENERAL REQUIREMENTS....Continued

Refer to TP-110T for testing vehicles other than passenger cars.

METRIC SYSTEM OF MEASUREMENT

Section 5164 of the Omnibus Trade and Competitiveness Act (Pub. L. 100-418) establishes that the metric system of measurement is the preferred system of weights and measures for trade and commerce in the United States. Executive order 12770 directs Federal agencies to comply with the Act by converting regulatory standards to the metric system after September 30, 1992. In a final rule published on March 15, 1990 (60 FR 13639), NHTSA completed the first phase of metrication, converting English measurements in several regulatory standards to the metric system. Since then, metrication has been applied to other regulatory standards (63 FR 28912).

Accordingly, the OVSC laboratory test procedures include revisions to comply with governmental directives in using the metric system. Regulatory standards converted to metric units are required to use metric measurements in the test procedures, whereas standards using English units are allowed to use English measurements or to use English measurements in combination with metric equivalents in parentheses. All final compliance test reports are required to include metric measurements for standards using metrication.

NOTE: The methodology for rounding measurement in the test reports shall be made in accordance with ASTM E29-06b, "Standard Practice for Using Significant Digits in Test Data to Determine Conformance with Specifications."

3. SECURITY

The contractor shall provide appropriate security measures to protect the OVSC test vehicles and Government Furnished Property (GFP) from unauthorized personnel during the entire compliance testing program. The contractor is financially responsible for any acts of theft and/or vandalism which occur during the storage of test vehicles and GFP. Any security problems which arise shall be reported by telephone to the Industrial Property Manager (IPM), Office of Acquisition Management, within two working days after the incident. A letter containing specific details of the security problem shall be sent to the IPM (with copy to the COTR) within 48 hours.

The contractor shall protect and segregate the data that evolves from compliance testing before and after each vehicle test. No information

3. SECURITY....Continued

concerning the vehicle safety compliance testing program shall be released to anyone except the COTR, unless specifically authorized by the COTR or the COTR's Division Chief.

NOTE: No individuals, other than contractor personnel directly involved in the compliance testing program or OVSC personnel, shall be allowed to witness any vehicle or equipment item compliance test or test dummy calibration unless specifically authorized by the COTR.

4. GOOD HOUSEKEEPING

Contractors shall maintain the entire vehicle compliance testing area, test fixtures and instrumentation in a neat, clean and painted condition with test instruments arranged in an orderly manner consistent with good test laboratory housekeeping practices.

5. TEST SCHEDULING AND MONITORING

The contractor shall submit a test schedule to the COTR prior to conducting the first compliance test. Tests shall be completed at intervals as required in the contract. If not specified, the first test shall be conducted within 6 weeks after receiving the first delivered unit. Subsequent tests shall be completed in no longer than 1 week intervals unless otherwise specified by the COTR.

Scheduling of tests shall be adjusted to permit vehicles (or equipment, whichever applies) to be tested to other FMVSSs as may be required by the OVSC. All compliance testing shall be coordinated with the COTR in order to allow monitoring by the COTR and/or other OVSC personnel if desired. The contractor shall submit a monthly test status report and a vehicle status report (if applicable) to the COTR. The vehicle status report shall be submitted until all vehicles are disposed of. The status report forms are provided in the forms section.

6. TEST DATA DISPOSITION

The Contractor shall make all vehicle preliminary compliance test data available to the COTR on location within 30 minutes after the test. Final test data, including digital printouts and computer generated plots (if applicable) shall be available to the COTR in accordance with the contract schedule or if not specified within two working days. Additionally, the Contractor shall analyze the preliminary test results as directed by the COTR.

6. TEST DATA DISPOSITION....Continued

All backup data sheets, strip charts, recordings, plots, technicians' notes, etc., shall be either sent to the COTR or destroyed at the conclusion of each delivery order, purchase order, etc.

The contractor shall protect and segregate the data that evolves from compliance testing before and after each test.

TEST DATA LOSS

A. INVALID TEST DESCRIPTION

An invalid compliance test is one, which does not conform precisely to all requirements/specifications of the OVSC Laboratory Test Procedure and Statement of Work applicable to the test.

B. INVALID TEST NOTIFICATION

The Contractor shall notify NHTSA of any test not meeting all requirements/specifications of the OVSC Laboratory Test Procedure and Statement of Work applicable to the test, by telephone, within 24 hours of the test and send written notice to the COTR within 48 hours of the test completion.

C. RETEST NOTIFICATION

The Contracting Officer of NHTSA is the only NHTSA official authorized to notify the Contractor that a retest is required. The retest shall be completed within 2 weeks after receipt of notification by the Contracting Officer that a retest is required.

D. WAIVER OF RETEST

NHTSA, in its sole discretion, reserves the right to waive the retest requirement. This provision shall not constitute a basis for dispute over the NHTSA's waiving or not waiving any requirement.

E. TEST VEHICLE

NHTSA shall furnish only one vehicle for each test ordered. The Contractor shall furnish the test vehicle required for the retest. The retest vehicle shall be equipped as the original vehicle. The original vehicle used in the invalid test shall remain the property of NHTSA, and the retest

6. TEST DATA DISPOSITION....Continued

vehicle shall remain the property of the Contractor. The Contractor shall retain the retest vehicle for a period not exceeding 180 days if it fails the test. If the retest vehicle passes the test, the Contractor may dispose of it upon notification from the COTR that the test report has been accepted.

F. TEST REPORT

No test report is required for any test that is determined to be invalid unless NHTSA specifically decides, in writing, to require the Contractor to submit such report. The test data from the invalid test must be safeguarded until the data from the retest has been accepted by the COTR. The report and other required deliverables for the retest vehicle are required to be submitted to the COTR within 3 weeks after completion of the retest.

G. DEFAULT

The Contractor is subject to the default and subsequent reprocurement costs for nondelivery of valid or conforming test (pursuant to the Termination For Default clause in the contract).

H. NHTSA'S RIGHTS

None of the requirements herein stated shall diminish or modify the rights of NHTSA to determine that any test submitted by the Contractor does not conform precisely to all requirements/specifications of the OVSC Laboratory Test Procedure and Statement of Work applicable to the test.

7. GOVERNMENT FURNISHED PROPERTY (GFP)

GFP consist of test vehicles, test equipment and instrumentation. The GFP is authorized by contractual agreement. The contractor is responsible for the following.

A. ACCEPTANCE OF TEST VEHICLES

The contractor has the responsibility of accepting each GFP test vehicle whether delivered by a new vehicle dealership or another vehicle transporter. In both instances, the contractor acts on behalf of the OVSC when signing an acceptance of the GFP test vehicle delivery order. When a GFP vehicle is delivered, the contractor must verify:

7. GOVERNMENT FURNISHED PROPERTY (GFP)....Continued

1. All options listed on the "window sticker" are present on the test vehicle.
2. Tires and wheel rims are new and the same as listed.
3. There are no dents or other interior or exterior flaws in the vehicle body.
4. The vehicle has been properly prepared and is in running condition.
5. The glove box contains an owner's manual, warranty document, consumer information, and extra set of keys.
6. Proper fuel filler cap is supplied on the test vehicle.
7. Spare tire, jack, lug wrench and tool kit (if applicable) is located in the vehicle cargo area.
8. The VIN (vehicle identification number) on the vehicle condition report matches the VIN on the vehicle.
9. The vehicle is equipped as specified by the COTR.

A Vehicle Condition form will be supplied to the contractor by the COTR when the test vehicle is transferred from a new vehicle dealership or between test contracts. The upper half of the form is used to describe the vehicle as initially accepted. The lower half of the Vehicle Condition form provides space for a detailed description of the post-test condition. The contractor must complete a Vehicle Condition form for each vehicle and deliver it to the COTR with the Final Test Report or the report will NOT be accepted for payment.

If the test vehicle is delivered by a government contracted transporter, the contractor should check for damage which may have occurred during transit.

GFP vehicle(s) shall not be driven by the contractor on public roadways unless authorized by the COTR.

B. TEST EQUIPMENT AND INSTRUMENTATION

The contractor has the responsibility of accepting GFP test equipment and instrumentation delivered to the contractor. The contractor acts on behalf of the OVSC when signing an acceptance of the GFP test equipment and instrumentation delivery order. When GFP test equipment and instrumentation is delivered, the contractor must:

7. GOVERNMENT FURNISHED PROPERTY (GFP)....Continued

1. Verify all partial and sub-component quantities as per the packaging document
2. Verify physical condition of all equipment and instrumentation (inspect for damage)
3. Verify functional condition of all equipment and instrumentation
4. Store in a clean, organized, secure, and environmentally controlled area

C. NOTIFICATION OF COTR

The COTR must be notified within 24 hours after a vehicle (and/or equipment item) has been delivered. In addition, if any discrepancy or damage is found at the time of delivery, a copy of the Vehicle Condition form shall be sent to the COTR immediately.

8. CALIBRATION OF TEST INSTRUMENTS

Before the contractor initiates the safety compliance test program, a test instrumentation calibration system will be implemented and maintained in accordance with established calibration practices. The calibration system shall include the following as a minimum:

- A. Standards for calibrating the measuring and test equipment shall be stored and used under appropriate environmental conditions to assure their accuracy and stability.
- B. All measuring instruments and standards shall be calibrated by the Contractor, or a commercial facility, against a higher order standard at periodic intervals not exceeding 12 months for instruments and 12 months for the calibration standards except for static types of measuring devices such as rulers, weights, etc., which shall be calibrated at periodic intervals not to exceed two years. Records, showing the calibration traceability to the National Institute of Standards and Technology (NIST), shall be maintained for all measuring and test equipment.
- C. All measuring and test equipment and measuring standards shall be labeled with the following information:
 - (1) Date of calibration

8. CALIBRATION OF TEST INSTRUMENTS....Continued

- (2) Date of next scheduled calibration
 - (3) Name of the technician who calibrated the equipment
- D. A written calibration procedure shall be provided by the Contractor, which includes as a minimum the following information for all measurement and test equipment:
- (1) Type of equipment, manufacturer, model number, etc.
 - (2) Measurement range
 - (3) Accuracy
 - (4) Calibration interval
 - (5) Type of standard used to calibrate the equipment (calibration traceability of the standard must be evident).
 - (6) The actual procedures and forms used to perform the calibrations.
- E. Records of calibration for all test instrumentation shall be kept by the Contractor in a manner that assures the maintenance of established calibration schedules.
- F. All such records shall be readily available for inspection when requested by the COTR. The calibration system shall need the acceptance of the COTR before vehicle safety compliance testing commences.
- G. Test equipment shall receive a system functional check out using a known test input immediately before and after the test. This check shall be recorded by the test technician(s) and submitted with the final report.
- H. The Contractor may be directed by NHTSA to evaluate its data acquisition system.

Further guidance is provided in the International Standard ISO 10012-1, "Quality Assurance Requirements for Measuring Equipment" and American National Standard ANSI/NCSS Z540-1, "Calibration Laboratories and Measuring and Test Equipment - General Requirements."

NOTE: In the event of a failure to meet the standard's minimum performance requirements, additional calibration checks of some critically sensitive test

8. CALIBRATION OF TEST INSTRUMENTS....Continued

equipment and instrumentation may be required for verification of accuracy. The necessity for the calibration will be at the COTR's discretion and will be performed without additional cost.

9. SUGGESTED TEST EQUIPMENT

- A. Data acquisition system to measure, calculate and provide a continuous recording of the time, velocity, distance, longitudinal acceleration and tire pressure of a vehicle (Racelogic Velocity Box model VBOX II DGPS or equivalent). The system should have the following target unit resolution and accuracy:

<u>Unit</u>	<u>Min. Range</u>	<u>Resolution</u>	<u>Accuracy</u>
Velocity	161 km/h	0.01 km/h	0.1 km/h full scale
Distance	1610 m	1 cm	0.05 %
Time	5 min	0.01 sec	0.001 sec
Long. Accel.	5 m/sec ²	0.01 g	0.5 %
Pressure	700 kPa	7 kPa	7 kPa

- B. Platform scales to measure individual wheel, axle, and vehicle loads with a maximum graduation of 0.5 kg (1 lb) and accuracy within ± 1 % of the measured reading. Scales are to allow for individual wheel measurements to be taken while maintaining all tire/ground interfaces on a common horizontal plane. Individual platform scale pad range/capacity is to exceed individual vehicle wheel loads.
- C. Temperature gage to measure ambient temperature with a 0 to 45 °C range, accuracy of ± 0.5 °C and a scale graduation of 1 degree.
- D. Tire pressure gage to measure static tire inflation pressure with a range of 700 kPa, accuracy of ± 7 kPa and with a maximum scale graduation of 7 kPa.
- E. Anemometer to measure wind speed. Ten m/s range with ± 1 m/s accuracy at 5 m/s and scale graduation of 1 m/s.
- F. Pressure Transducer to measure tire inflation pressure while test vehicle is in motion with a range of 700 kPa, accuracy of ± 7 kPa and with a maximum scale graduation of 7 kPa.
- G. Laser Level with Digital Protractor Inclinometer to measure road surface grade and for leveling weight scales during vehicle load analyses with 360

9. SUGGESTED TEST EQUIPMENT....Continued

degree range and ± 0.1 degree accuracy and 0.1 degree resolution.

- H. Tape measure or ruler to measure rim dimensions with 1 m range and 1.0 mm scale graduation.
- I. Latest edition of approved Tire and Rim reference manual as identified in FMVSS No. 110.

10. PHOTOGRAPHIC DOCUMENTATION

DIGITAL PHOTOGRAPHS

The contractor shall take digital photographs of the pretest, test execution and post test conditions. Photographs shall be taken in color and contain clear images. A tag, label or placard identifying the test item, NHTSA number (if applicable) and date shall appear in each photograph and must be legible. Each photograph shall be labeled as to the subject matter. The required resolution for digital photographs is a minimum of 1,600 x 1,200 pixels. Digital photographs are required to be created and in a JPG format. Glare or light from any illuminated or reflective surface shall be minimized while taking photographs. The test setup and equipment used in all tests shall be photographed for the record before and at prescribed time periods during testing.

The test reports shall include enough photographs to describe the testing in detailed and shall be organized in a logical succession of consecutive pictures.

The digital photographs shall be included in the test report as 203 mm x 254 mm or 215.9 mm x 279 mm (8 x 10 or 8½ x 11 inch) pictures. All photographs are required to be included in the test report in the event of a test failure. Any failure must be photographed at various angles to assure complete coverage. Upon request, the photographs shall be sent to the COTR on a CD or DVD and saved in a "read only" format to ensure that the digital photographs are the exact pictures taken during testing and have not been altered from the original condition.

PHOTOGRAPHIC VIEWS

As a minimum the following test photographs shall be included in each vehicle final test report, submitted by the contractor:

- A. 3/4 frontal view from left side of vehicle
- B. 3/4 rear view from right side of vehicle
- C. Vehicle's Certification Label
- D. Alterer's Label (if attached)

10. PHOTOGRAPHIC DOCUMENTATION....Continued

- E. Vehicle Placard
- F. Tire Inflation Pressure Label (if attached)
- G. Load Carrying Capacity Modification Label (if attached)
- H. Monroney Label (if attached)
- I. Distributor/Dealer option/accessory label (if attached)
- J.. Tire showing brand and model
- K. Tire showing size, load index and speed symbol
- L. Tire showing load rating and inflation pressure
- M. Tire showing serial number
- N. Rim contour for full width of rim cross section
- O. Rim markings (if any)
- P. Close-up of test instrumentation used for tire blow-out
- Q. Close-up of blow-out tire with ruler next to hole
- R. Close-up of interior seating position simulated occupant ballast
- S. Close-up of interior cargo simulated ballast
- T. View of vehicle on weight scales
- U. Pertinent Owner's manual pages
- V. Close-up of all test failure areas and components

11. DEFINITIONS

ACCESSORY WEIGHT

The combined weight (in excess of those standard items which may be replaced) of automatic transmission, power steering, power brakes, power windows, power seats, radio, and heater, to the extent that these items are available as factory-installed equipment (whether installed or not).

CURB WEIGHT

The weight of a motor vehicle with standard equipment including the maximum capacity of fuel, oil, and coolant, and, if so equipped, air conditioning and additional weight optional engine.

MAXIMUM LOADED VEHICLE WEIGHT

The sum of curb weight, accessory weight, vehicle capacity weight, and production options weight.

NORMAL OCCUPANT WEIGHT

68 kilograms times the number of Normal Load occupants as determined by the

11. DEFINITIONS....Continued

vehicle's Designated Seating Capacity (DSC) in the following table:

VEHICLE DSC NUMBER OF OCCUPANTS	VEHICLE NORMAL LOAD NUMBER OF OCCUPANTS
2 through 4	2
5 through 10	3
11 through 15	5
16 through 22	7

OCCUPANT DISTRIBUTION

Distribution of normal load occupants as specified in the following table:

VEHICLE NORMAL LOAD NUMBER OF OCCUPANTS	OCCUPANT DISTRIBUTION
2	2 in Front
3	2 in Front and 1 in Second Seat
5	2 in Front, 1 in Second Seat, 1 in Third Seat, and 1 in Fourth Seat.
7	2 in Front, 2 in Second Seat, 2 in Third Seat, and 1 in Fourth Seat.

PRODUCTION OPTIONS WEIGHT

The combined weight of those installed regular production options weighing over 2.3 kilograms in excess of those standard items which they replace, NOT previously considered in Curb Weight or Accessory Weight, including heavy duty brakes, ride levelers, roof rack, heavy duty battery, and special trim.

STOPPING DISTANCE

Distance vehicle travels from start of pedal force to complete stop.

VEHICLE CAPACITY WEIGHT

The rated cargo and luggage load plus 68 kilograms times the vehicle's Designated Seating Capacity (DSC).

11. DEFINITIONS....Continued

VEHICLE MAXIMUM LOAD ON THE TIRE

The load on an individual tire that is determined by distributing to each axle its share of the maximum Loaded Vehicle Weight and dividing by 2.

VEHICLE NORMAL LOAD ON THE TIRE

The load on an individual tire that is determined by distributing to each axle its share of the Curb Weight, Accessory Weight, and Normal Occupant Weight and dividing by 2.

12. PRETEST REQUIREMENTS

IN-HOUSE COMPLIANCE TEST PROCEDURE

Prior to conducting any compliance tests, contractors are required to submit a detailed in-house compliance test procedure and equipment list to the COTR which includes a step-by-step description of the methodology to be used and a detailed check-off list. Written approval will be obtained from the COTR before commencing testing so that all parties are in agreement. The contractor's test procedure will contain a complete listing of test equipment and a detailed check-off list. There will be no contradiction between the OVSC Laboratory Test Procedure and the contractor's in-house test procedure. The list of test equipment will include instrument accuracy and calibration dates.

GENERAL TEST CONDITIONS

- A. For the execution of this test the Maximum Loaded Vehicle Weight is the sum of the Vehicle Curb Weight and the Vehicle Capacity Weight. The Vehicle Normal Load Weight is the sum of the Vehicle Curb Weight and the Normal Occupant Weight. The Vehicle Curb Weight is the weight of the test vehicle as delivered including installed accessories and options, and the maximum capacity of fuel, oil and coolant.
- B. For loading of simulated occupant ballast each adjustable seat should be positioned to its mid forward-to-aft and mid up-to-down seat position adjustment ranges.
- C. Adult simulated occupant load ballast for each designated seating positions is 68 kg (150 lb). 54 kg (120 lb) of ballast should be placed on the seat and 14 kg (30 lb) should be placed on the floor directly in front of the respective seating position.

12. PRETEST REQUIREMENTS....Continued

- D. All measurements, weighing and dynamic portions of the test should be

performed with ambient air temperatures between 0°C and 38°C.

- E. The deflated tire retention test should be performed on a straight, dry and paved surface with grades in any direction not exceeding 1 % and a wind velocity not exceeding 5 m/s.
- F. At the start of the deflated tire retention test the fuel tank should be at least 90 percent full.
- G. The driver and observer (if present) should be restrained with the vehicle by properly adjusted seat belt, head restraint, and any protective device included in the vehicle during the deflated tire retention test. Other protective devices are optional to the testing agent.

13. COMPLIANCE TEST EXECUTION

Personnel supervising and/or performing the compliance test program should be thoroughly familiar with the requirements, test conditions, and equipment for the test to be conducted. Testing should be accomplished as indicated below. Test personnel should make note of all discrepancies and deviations from the applicable FMVSS and the Laboratory Test Procedure.

13.1 TEST VEHICLE INFORMATION (Data Sheet 1)

Inspect the vehicle, Monroney label and other affixed labels and record test vehicle information as required on data sheet 1. Identify options, accessories, and equipment installed on the vehicle at the time of test. From the optional and accessory equipment list developed, if identified on the vehicle labeling, make note of the equipment installed by the distributor or dealer after the vehicle was completed by the OEM.

13.2 VEHICLE TIRE IDENTIFICATION (Data Sheet 2)

- A. Visually inspect all the tires on the vehicle including the spare tire. If all the tires are not the same size, explain under REMARKS.
- B. Record the tire sidewall information for the right front tire and the spare tire (if different). If the front axle tire size is different than the rear tire size also record the sidewall information for the left rear tire.

13. COMPLIANCE TEST EXECUTION....Continued

- C. Record the serial numbers from all vehicle tires.

- D. Verify that all tires are marked with “DOT” certifying compliance to applicable tire performance FMVSS.

13.3 VEHICLE RIM IDENTIFICATION (Data Sheet 3)

- A. Remove the right front and left rear wheels (tires and rims) from the vehicle. Before removing either wheel, place an identification mark on each rim and corresponding wheel hub, stud or bolt such that after removal the wheel may be remounted in its original position on the vehicle relative to the corresponding hub, stud or bolt.
- B. For each wheel removed from the vehicle in step A, remove each tire from its rim. Before removing a tire from its rim, place an identification mark on each tire and each corresponding rim flange such that after removal of the tire from the rim the tire may be remounted in its original position relative to the rim.
- C. Visually inspect each rim. Record any visible rim markings including manufacturer's name, symbol or trademark, rim size, load rating and maximum inflation pressure, date of manufacture, DOT symbol and any other markings. Record any damage, rough or sharp areas, or defects that may affect the function or performance of the rim. Inspect the tire bead area for loose rubber, cords, or other defects that may affect its performance. Request COTR instruction for repair or replacement of any defects found.
- D. Measure the rim at a cross section within 8 cm of the valve hole and record the rim width and diameter. If the rim size is stamped on the rim verify that the stamped size is the same as the measured size. Mark the measured cross section with a durable mark.
- E. Provide a legible photograph of each the rim contour for the full width of the rim at the same location as measured and marked above.
- F. Verify that installed rim size and contour at each wheel position is suitable for the corresponding installed tire by comparing rim dimensions stamped and/or measured with those indicated in an approved tire and rim reference manual.
- G. Remount tires on corresponding rims and install wheels back onto the vehicle. Ensure tires are mounted in their original positions relative to each rim and vehicle hub, stud or bolt as marked in steps A. and B.

13. COMPLIANCE TEST EXECUTION....Continued

above.

- H. Determine and report as Pass or Fail. Passenger car rims are to be suitable for installed tires but there are no rim marking requirements specified for passenger cars in FMVSS 110.

13.4 VEHICLE PLACARD, TIRE INFLATION PRESSURE LABEL, LOAD CARRYING CAPACITY MODIFICATION LABEL, AND OTHER LABELS (Data Sheet 4)

- A. Record locations of vehicle certification label, vehicle placard, and if provided, tire inflation pressure label, load carrying capacity modification label, Monroney label, alterer's label, and/or separate distributor/dealer optional equipment label.
- B. Compare the **Vehicle Placard** and, if provided, the **Tire Inflation Pressure Label** and the **Load Carrying Capacity Modification Label** formats to the sample formats provided on data sheet 4 and verify that they are exactly the same and the text is in the English language. While comparing label formats review the labeling notes provided below the sample labels and note any discrepancies.
- C. Document the information provided on the vehicle placard and tire inflation pressure label including combined weight of occupants and cargo (vehicle capacity weight), seating capacity, tire size(s) and cold tire pressure(s).
- D. Compare the actual number of seating positions (belted positions) with the placard number of seating positions.
- E. Compare the vehicle installed tire size(s) with the labeled tire size(s).
- F. Verify that the labeled cold tire inflation pressures are equal to or less than the maximum tire inflation pressures marked on the sidewall of the installed tires.
- G. Document the information provided on the load carrying capacity modification label (if provided) including the amount the vehicle placard load carry capacity is reduced. Measure and document the label print size (height) and distance from vehicle placard.
- H. If the test vehicle has an attached Monroney label, record the tire size listed on the label. Make note if the tire size specified on the label is the same size as is installed on the vehicle.

13. COMPLIANCE TEST EXECUTION....Continued

- I. If the vehicle has an affixed separate distributor/dealer optional equipment

label, document listed equipment.

13.5 CURB WEIGHT, NORMAL LOAD WEIGHT AND MAXIMUM VEHICLE WEIGHT
(Data Sheet 5)

- A. Check all vehicle fluids and fill to manufacturer's recommended capacity.
- B. Adjust tire pressures of all tires to that appearing on the vehicle placard or tire inflation pressure label.
- C. Position appropriate scales on level surface in laboratory test area. Using a laser and digital protractor inclinometer (or equivalent) ensure leveling of scales front-to-back, side-to-side and corner-to-corner. Adjust scales to obtain tire/ground load measurements on a common horizontal plane.
- D. Weigh and record the **Vehicle Curb Weight** including weight of each wheel position and calculate axle and vehicle weights.
- E. Record total seating capacity from the vehicle placard.
- F. Determine the number of occupants and occupant distribution for vehicle normal load as specified in section 11, *Definitions*, of this test procedure. Calculate and record the total normal occupant load.
- G. Ballast the vehicle to simulate a normal occupant load by placing appropriate ballast in each of the respective normal load seating positions. For proper seat adjustment and ballast placement refer to the general test conditions in section 12. Record the weight of each wheel position and calculate the **Vehicle Normal Load on the Axles**.
- H. Calculate and record the "Vehicle Normal Load on the Tire" and "Value of 94% of the Load Rating at the Vehicle Manufacturer's Recommended Cold Inflation Pressure" as instructed on the Data Sheet 5 (Section B (5) and (6)). Verify that the Vehicle Normal Load on the Tire for each axle is not greater than the Value of 94% of the Load Rating at the Vehicle Manufacturer's Recommended Cold Inflation Pressure.
- I. Record total seating capacity and occupant distribution from the vehicle placard. Calculate and record weight of full occupant load.

13. COMPLIANCE TEST EXECUTION....Continued

- J. Ballast the vehicle to simulate a full occupant load by placing appropriate

ballast in each of the designated seating positions. For proper seat adjustment and ballast placement refer to the general test conditions in section 12. Record the weight of each wheel position and calculate the **Vehicle Weight with Full Occupant Load**.

- K. Calculate the vehicle's luggage/cargo load as instructed on Data Sheet 5 (Section D. (1)–(5)).
- L. Ballast the vehicle to simulate the luggage/cargo load calculated above. The ballast should be placed in the appropriate cargo loading area(s) and distributed uniformly fore/aft and side/side. If the vehicle has more than one cargo area (trunk, behind the rear seat, roof rack, etc.) consult the owner's manual and the COTR for further guidance concerning cargo placement. Record the weight of each wheel position and calculate the **Vehicle Maximum Load on the Axles**.
- M. Calculate and record the "Vehicle Maximum Load on the Tire" as instructed on Data Sheet 5 (Section D. (7)).
- N. Verify that the Maximum Load on the Tire is not greater than the Maximum Load Rating on the tire sidewall as instructed on Data Sheet 5 (Section D. (8)).
- O. Verify that the "normal load on the tire" and the "maximum load on the tire" are not greater than the tire load ratings at the vehicle manufacturer recommended cold inflation pressure(s) provided on the vehicle placard or tire inflation pressure label as instructed on Data Sheet 5 (Section D. (9)).

13.6 DEFLATED TIRE RETENTION (Data Sheet 6)

- A. Adjust tire pressure of all tires to the vehicle placard cold tire inflation pressure. Record final adjusted tire inflation pressures.
- B. Load vehicle to the maximum loaded vehicle weight and corresponding vehicle maximum load on each axle as obtained and recorded on Data Sheet 5 (Section D.(6)). of this test procedure. To obtain this load the vehicle is loaded with required test instrumentation, full fluids, a driver and simulated occupant/cargo ballast. Record weight by axle and wheel position.
- C. Secure all added items and ballast in vehicle.

13. COMPLIANCE TEST EXECUTION....Continued

- D. With the vehicle traveling in a straight line at 97 kmph (+ 0 kmph, - 2

kmph), simulate the rapid loss of inflation pressure in the left front tire through an opening at least equal to a 1.3 cm diameter hole. Upon initial release of air, bring the vehicle to a stop using the most rapid constant deceleration rate attainable not exceeding 2.5 m/sec^2 (8 ft/sec^2) with no wheel skid. Record vehicle speed, tire pressure, deceleration, stopping distance (distance traveled after initial release of air), distance of uncontrolled deviation from a straight line, and test conditions. Permanent, continuous recording is required for time, vehicle speed, tire pressure and deceleration rate.

- E. With the vehicle remaining in the stopped position, photographically record and verbally describe all separation of the tire bead from the rim flange on both inboard and outboard sides of the rim under test. Rotation of the wheel to permit access to upper inboard positions of the tire should be done after outboard and lower inboard information is recorded.
- F. Return the vehicle to pretest condition. Repeat Items A through E, using the right rear tire position (or other as directed).
- G. Determine and report a pass or fail for each wheel position tested. Each rim should be capable of retaining its respective tire during a rapid loss of inflation pressure at 97 kilometers per hour and until the vehicle can be stopped with a controlled braking application.

13.7 OWNER'S MANUAL REQUIREMENTS (Data Sheet 7)

Review the vehicle owner's manual, or other manufacturer document if an owner's manual is not provided, and verify that the information as specified on data sheet 7 is discussed and/or stated. The basis of these requirements is Part 575.6. Copy applicable pages of the owner's manual or other document for inclusion in the Final Test Report.

14. POST TEST REQUIREMENTS

Return the vehicle to pretest condition utilizing replacement tires of the exact

brand, model and size as the original tires and wheels in their original positions on the vehicle as labeled and marked. Substitute tires may be installed only as directed by the COTR. Use of spare wheel and tire are to be as directed by the COTR.

After the required tests are completed, the contractor shall:

- A. Verify all data sheets complete and photographs taken,
- B. Complete Data Summary Sheets,
- C. Complete the Vehicle Condition report form including a word description of its post test condition,
- D. Copy applicable pages of the vehicle Owner's Manual for attachment to the final test report,
- E. Remove all instrumentation from vehicle. Return vehicle to its pretest condition.
- F. Move the test vehicle to a secure area,
- G. Place all original records in a secure and organized file awaiting test data disposition.

15. REPORTS

15.1. MONTHLY STATUS REPORTS

The contractor will submit a monthly Test Status Report and a Vehicle Status Report to the COTR. The Vehicle Status report will be submitted until all vehicles are disposed of. Samples of the required reports are found in the report forms section.

15.2. APPARENT NONCOMPLIANCE

Any indication of a test failure shall be communicated by telephone to the COTR within 24 hours with written notification mailed within 48 hours (Saturdays and Sundays excluded). A Notice of Test Failure (see report forms section) with a copy of the particular compliance test data sheet(s) and preliminary data plot(s) shall be included. In the event of a test failure, a post test calibration check of some critically sensitive test equipment and instrumentation may be required for verification of accuracy. The necessity for the calibration shall be at the COTR's discretion and shall be performed without additional costs to the OVSC.

15.3 FINAL TEST REPORTS

15.3.1 COPIES

In the case of an apparent test failure, seven paper copies and 2 CD electronic copies in both Word and pdf formats of the Final Test Report shall be submitted to the COTR for acceptance within three weeks of test completion. The Final Test Report format to be used by all contractors can be found in the "Report Section".

Where there has been no indication of an apparent noncompliance, three paper copies and 2 CD electronic copies in both Word and pdf formats of each Final Test Report shall be submitted to the COTR for acceptance within three weeks of test completion. No payment of contractor's invoices for conducting compliance tests will be made prior to the Final Test Report acceptance by the COTR. Contractors are requested to NOT submit invoices before the COTR is provided with copies of the Final Test Report.

Contractors are required to submit the first Final Test Report in draft form within one week after the compliance test is conducted. The contractor and the COTR will then be able to discuss the details of both test conduct and report content early in the compliance test program. Contractors are required to PROOF READ all Final Test Reports before submittal to the COTR. The OVSC will not act as a report quality control office for contractors. Reports containing a significant number of errors will be returned to the contractor for correction, and a "hold" will

15. REPORTS...Continued

be placed on invoice payment for the particular test.

15.3.2 REQUIREMENTS

The Final Test Report and associated documentation (including photographs) are relied upon as the chronicle of the compliance test. The Final Test Report will be released to the public domain after review and acceptance by the COTR.

For these reasons, each final report must be a complete document capable of standing by itself. The contractor should use DETAILED descriptions of all compliance test events. Any events that are not directly associated with the standard but are of technical interest should also be included. The contractor should include as much DETAIL as possible in the report. Instructions for the preparation of the first three pages of the final test report are provided for standardization.

15.3.3 FIRST THREE PAGES

A. FRONT COVER

A heavy paperback cover (or transparency) will be provided for the protection of the final report. The information required on the cover is as follows:

(1) Final Report Number such as 110-ABC-0X-001, where –

110 is the FMVSS tested
 ABC are the initials for the laboratory
 0X is the Fiscal Year of the test program
 001 is the Group Number (001 for the 1st test,
 002 for the 2nd test, etc.)

(2) Final Report Title And Subtitle such as

SAFETY COMPLIANCE TESTING FOR FMVSS 110
 Tire Selection and Rims
 * * * * *
 ABC Motor Company
 200X Saferider 4-door sedan
 NHTSA No. CX0401

15. REPORTS....Continued

- (3) Contractor's Name and Address such as

COMPLIANCE TESTING LABORATORIES, INC.
4335 West Dearborn Street
Detroit, Michigan 48090-1234

NOTE: DOT SYMBOL WILL BE PLACED BETWEEN ITEMS (3) AND (4)

- (4) Date of Final Report completion

- (5) The words "FINAL REPORT"

- (6) The sponsoring agency's name and address as follows

U. S. DEPARTMENT OF TRANSPORTATION
National Highway Traffic Safety Administration
Enforcement
Office of Vehicle Safety Compliance
Mail Code: NVS-220
1200 New Jersey Avenue, S.E.
Washington, DC 20590

15. REPORTS...Continued

B. FIRST PAGE AFTER FRONT COVER

When a contract test laboratory is reporting, a disclaimer statement and an acceptance signature block for the COTR shall be provided as follows:

This publication is distributed by the National Highway Traffic Safety Administration in the interest of information exchange. Opinions, findings and conclusions expressed in this publication are those of the author(s) and not necessarily those of the Department of Transportation or the National Highway Traffic Safety Administration. The United States Government assumes no liability for its contents or use thereof.

If trade or manufacturers' names or products are mentioned, it is only because they are considered essential to the object of the publication and should not be construed as an endorsement.

Prepared By: _____

Approved By: _____ *

Approval Date: _____ *

FINAL REPORT ACCEPTANCE BY OVSC:*

Accepted By: _____

Acceptance Date: _____

* These lines not required when OVSC staff writes the Test Report

15. REPORTS....Continued**C. SECOND PAGE AFTER FRONT COVER**

A completed Technical Report Documentation Page (Form DOT F1700.7) will be completed for those items that are applicable with the other spaces left blank. Sample data for the applicable block numbers of the title page follows.

Block 1 — REPORT NUMBER

110-ABC-0X-001

Block 2 — GOVERNMENT ACCESSION NUMBER

Leave blank

Block 3 — RECIPIENT'S CATALOG NUMBER

Leave blank

Block 4 — TITLE AND SUBTITLE

Final Report of FMVSS 110 Compliance Testing of 200X Saferider
4-door sedan, NHTSA No. CX0401

Block 5 — REPORT DATE

March 1, 200X

Block 6 — PERFORMING ORGANIZATION CODE

ABC

Block 7 — AUTHOR(S)

John Smith, Project Manager
Bill Doe, Project Engineer

Block 8 — PERFORMING ORGANIZATION REPORT NUMBER

ABC-DOT-XXX-001

15. REPORTS....Continued**Block 9 — PERFORMING ORGANIZATION NAME AND ADDRESS**

ABC Laboratories
405 Main Street
Detroit, MI 48070-1234

Block 10 — WORK UNIT NUMBER

Leave blank

Block 11 — CONTRACT OR GRANT NUMBER

DTNH22-0X-D-12345

Block 12 — SPONSORING AGENCY NAME AND ADDRESS

United States Department of Transportation
National Highway Traffic Safety Administration
Office of Vehicle Safety Compliance
1200 New Jersey Avenue, S.E.
Washington, DC 20590

Block 13 — TYPE OF REPORT AND PERIOD COVERED

Final Test Report
Feb. 15 to Mar. 15, 200X

Block 14 — SPONSORING AGENCY CODE

NVS-220

Block 15 — SUPPLEMENTARY NOTES

Leave blank

15. REPORTS...Continued

Block 16 — ABSTRACT

Compliance tests were conducted on the subject 200X Saferider 4-door sedan in accordance with the specifications of the Office of Vehicle Safety Compliance Test Procedure No. TP-110P-0X for the determination of FMVSS 110 compliance. Test failures identified were as follows:

None

NOTE: Above wording will be shown with appropriate changes made for a particular compliance test. Any questions should be resolved with the COTR.

Block 17 — KEY WORDS

Compliance Testing
Safety Engineering
FMVSS 110

Block 18 — DISTRIBUTION STATEMENT

Copies of this report are available from —

National Highway Traffic Safety Administration
Technical Information Services (NPO-411)
1200 New Jersey Ave., S.E.
Washington DC 20590

e-mail: tis@dot.gov
FAX: 202-493-2833

Block 19 — SECURITY CLASSIFICATION OF REPORT

Unclassified

Block 20 — SECURITY CLASSIFICATION OF PAGE

Unclassified

Block 21 — NUMBER OF PAGES

Add appropriate number

15. REPORTS...Continued

Block 22 — PRICE

Leave blank

15.3.4 TABLE OF CONTENTS

Final test report Table of Contents will include the following:

Section 1 — Purpose of Compliance Test

Section 2 — Test Procedure and Discussion of Results

Section 3 — Test Data

Section 4 — Test Equipment List and Calibration Information

Section 5 — Photographs

Section 6 — Other Documentation

Section 7 — Notice of Test Failure (if applicable)

16. DATA SHEETS

DATA SUMMARY SHEET (1 of 2)

VEHICLE MAKE/MODEL/BODY STYLE: _____

VEHICLE NHTSA NO.: _____ VIN: _____

VEHICLE TYPE: _____ DATE OF MANUFACTURE: _____

LABORATORY: _____

PASSENGER CAR REQUIREMENTS**PASS/FAIL****General** (Data Sheet 2)

The vehicle is equipped with tires that meet the requirements of S139. _____
(S110, S4.1)

Tire Load Limits (Data Sheet 5)

The vehicle maximum load on the tire is not greater than the _____
maximum load rating as marked on the sidewall of the tire. (S110, S4.2.1.1)

The vehicle normal load on the tire is not greater than the value of _____
94 percent of the load rating at the vehicle manufacturer's
recommended cold inflation pressure for that tire. (S110, S4.2.1.2)

**Vehicle Placard, Tire Inflation Pressure Label, and Load Carrying Capacity
Modification Label** (Data Sheets 4 and 5)

The placard, tire inflation pressure label (if attached), and load carrying _____
capacity modification label (if attached) are affixed and located correctly,
and display the information and format required. (S110, S4.3 and S10.1(a))

No inflation pressure other than the maximum permissible inflation _____
pressure may be shown on the placard and, if any, tire inflation pressure
label unless as required. (S110, S4.3.4)

16. DATA SHEETS....continued

DATA SUMMARY SHEET (2 of 2)

Rims (Data Sheets 3 and 6)

Each rim is constructed to the dimensions of a rim referred to in _____
FMVSS 139 that is listed by the manufacturer of the tires as suitable for use
with those tires. (S110, S4.4.1(a))

Vehicle rims retain deflated tires during a controlled braking application. _____
(S110, S4.4.1(b))

Owner's Manual (Data Sheet 7)

Owner's manual or other document has discussion of Vehicle Placard, _____
Loading and Tires. (575.6 (a)(4))

Owner's manual includes exact statement relating to "Steps for _____
Determining Correct Load Limits." (575.6(a)(5))

RECORDED BY: _____

DATE: _____

APPROVED BY: _____

DATE: _____

16. DATA SHEETS....continued

**DATA SHEET 1
TEST VEHICLE INFORMATION/RECEIVING INSPECTION**

VEHICLE MAKE/MODEL/BODY STYLE: _____

NHTSA No.: _____ TEST DATE: _____

VIN: _____ MANUFACTURE DATE: _____

GVWR: _____ KG FRONT GAWR: _____ KG REAR GAWR _____ KG

SEATING POSITIONS: TOTAL _____ FRONT _____ REAR _____

ODOMETER READING AT START OF TEST: _____ KILOMETERS

ENGINE DATA: _____ Cylinders _____ Liters _____ Cubic Inches

TRANSMISSION DATA: _____ Automatic _____ Manual _____ Automatic with manual shift capability

FINAL DRIVE DATA: _____ Rear Drive _____ Front Drive _____ 4 or All Wheel Drive

MANUFACTURER/DEALER/DISTRIBUTOR INSTALLED OPTIONS AND ACCESSORIES (From Monroney label or other labels on vehicle) :

<input type="checkbox"/>	Power Windows	<input type="checkbox"/>	Blind Spot Monitoring	<input type="checkbox"/>	Grill Upgrade
<input type="checkbox"/>	Power Door Locks	<input type="checkbox"/>	Running Boards	<input type="checkbox"/>	Block Heater
<input type="checkbox"/>	Power Seat(s)	<input type="checkbox"/>	Heated Mirrors	<input type="checkbox"/>	Backup Camera
<input type="checkbox"/>	Navigation System	<input type="checkbox"/>	Floor/Trunk Mats	<input type="checkbox"/>	Remote Start
<input type="checkbox"/>	Satellite Radio	<input type="checkbox"/>	Spoiler Kit	<input type="checkbox"/>	Other:
<input type="checkbox"/>	Sun Roof or T-Top	<input type="checkbox"/>	Heated/Cooled Seats	<input type="checkbox"/>	
<input type="checkbox"/>	Cruise Control	<input type="checkbox"/>	Cargo Net/Luggage Compartment Cover	<input type="checkbox"/>	
<input type="checkbox"/>	Splash Guards	<input type="checkbox"/>	Upgraded Wheel Package	<input type="checkbox"/>	
<input type="checkbox"/>	Roof Rack	<input type="checkbox"/>	Trailer Hitch/Tow Package	<input type="checkbox"/>	

Does vehicle labeling identify optional and accessory equipment installed by the distributor and/or dealer?

() YES* () NO

* If yes, identify the equipment by asterisk above.

REMARKS:

RECORDED BY: _____

DATE: _____

APPROVED BY: _____

DATE: _____

16. DATA SHEETS....continued

**DATA SHEET 3
VEHICLE RIM IDENTIFICATION**

VEHICLE MAKE/MODEL/BODY STYLE: _____

VEHICLE NHTSA NO. _____ VIN: _____

LABORATORY: _____ TEST DATE: _____

Rim Markings (if available):	Right Front	Left Rear
Manufacturer's Name, Symbol or Trademark	_____	_____
Rim Size	_____	_____
Load Rating and Max Inflation Pressure	_____	_____
Date of Manufacture	_____	_____
Does Rim contain "DOT" symbol? (YES/NO)	_____	_____
Other Rim Markings	_____	_____

Rim Inspection Comments: _____

Tire Inspection Comments: _____

Rim Size:	Tire Size	Measured Rim Width	Measured Rim Diameter
Right Front Wheel	_____	_____	_____
Left Rear Wheel	_____	_____	_____

Does stamped rim size (if available) agree with the measured rim size? () Not Applicable
 Right front rim () YES () NO; Left rear rim () YES () NO

Installed rims are suitable for installed tires? () YES () NO
 Reference document; _____

DATA INDICATES COMPLIANCE: PASS/FAIL _____

REMARKS:

RECORDED BY: _____ DATE: _____
 APPROVED BY: _____ DATE: _____

16. DATA SHEETS....continued

**DATA SHEET 4 (1 of 5)
VEHICLE PLACARD, TIRE INFLATION PRESSURE LABEL, AND OTHER LABELS**

VEHICLE MAKE/MODEL/BODY STYLE:

VEHICLE NHTSA NO. _____

VIN: _____

LABORATORY: _____

TEST DATE: _____

MANUFACTURE DATE: _____

Identification of Vehicle Labeling

	(Yes/No)	Location	PASS/FAIL
1. Monroney Label (if attached)	_____	_____	<u>Not Applicable</u>
2. Certification Label*	_____	_____	<u>Not Applicable</u>
3. Alterer's Label (if attached)	_____	_____	<u>Not Applicable</u>
4. Vehicle Placard*	_____	_____	_____
5. Tire Inflation Pressure Label* (if attached)	_____	_____	_____
6. Load Carrying Capacity Modification Label* (if attached)	_____	_____	_____
7. Dealer/Distributor Optional Equipment Added Label (if attached)	_____	_____	<u>Not Applicable</u>

* Labels are to be affixed to the driver's side B-pillar otherwise refer to FMVSS 110 requirements.

16. DATA SHEETS....continued

DATA SHEET 4 (2 of 5)

VEHICLE PLACARD, TIRE INFLATION PRESSURE LABEL, AND OTHER LABELS

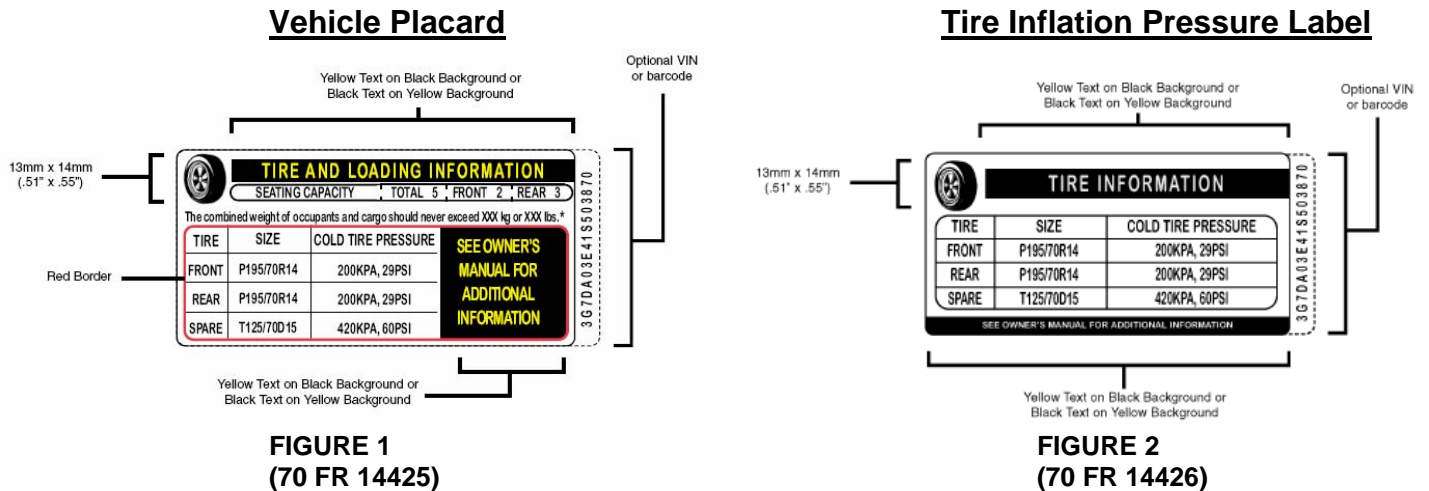

Load Carrying Capacity Modification Label

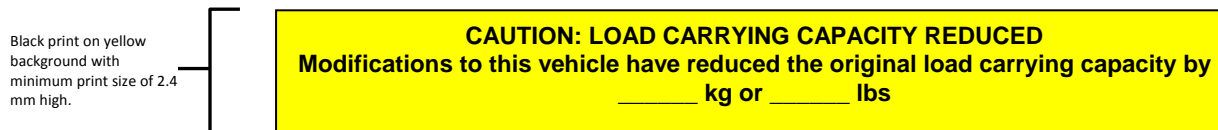

FIGURE 3
(72 FR 68465)

Labeling Notes:

1. Tire size and pressure can be omitted from the Vehicle Placard if same data is displayed on a Tire Inflation Pressure Label.
2. The Alphanumeric Identifier or Barcode, is optional. It can be located vertically, along the right edge or the left edge of the placard or the label, or horizontally, along the bottom edge of the placard or the label.
3. Tire size can include the tire load range identification symbol ("XL" or "reinforced", "B", "C", "D", "E", or "F"), the load index number, and the speed rating symbol, located immediately to the right of the tire size designation.
4. The tire "SIZE" heading can be replaced with "ORIGINAL TIRE SIZE" or "ORIGINAL SIZE."
5. The "SPARE" tire heading can be replaced with "SPARE TIRE."
6. For full size spare tires, the recommended cold tire inflation pressure can be replaced with "SEE ABOVE".
7. If no spare tire is provided, the word "NONE" is to replace the manufacturer's cold tire inflation pressure.

16. DATA SHEETS....continued

DATA SHEET 4 (3 of 5)

VEHICLE PLACARD, TIRE INFLATION PRESSURE LABEL, AND OTHER LABELS

Vehicle Placard has the exact color and format as specified in the above

Figure 1 and text is in English language. YES NO

If no, explain _____

Tire Inflation Pressure Label, if attached, has the exact color and format as specified in the above Figure 2 and text is in English language. YES NO

If no, explain _____

Load Carrying Capacity Modification Label, if attached, has the exact color and format as specified in the above Figure 3 and text is in the English language. Additionally, the label is within 25 mm of vehicle placard and has minimum print size of 2.4 mm high. YES NO

If no, explain _____

Vehicle Placard and, if attached, **Tire Inflation Pressure Label** and the **Load Carrying Capacity Modification Label** are permanently affixed.

YES NO

Vehicle Placard information:

Combined weight of occupants and cargo _____ kg (_____ lbs)

Seating Capacity: Total _____; Front _____; Rear _____;

Is the number of belted seating positions the same as the labeled seating capacity? YES NO

If no, explain _____

Is the tire size and pressure provided? YES NO

If no, is the tire size and pressure provided on a **Tire Inflation Pressure Label**?

YES NO

16. DATA SHEETS....continued

DATA SHEET 4 (4 of 5)
VEHICLE PLACARD, TIRE INFLATION PRESSURE LABEL, AND OTHER LABELS

Vehicle Placard or Tire Inflation Pressure Label tire information:

Tire Size: Front _____; Rear _____

Tire Inflation Pressure: Front _____; Rear _____

Are the sizes of the installed tires the same as the sizes of the labeled tires?
 YES NO

If no, explain _____

Is the labeled cold tire inflation pressure equal to or less than the sidewall labeled maximum cold tire inflation pressure?

Front axle: YES NO Rear axle: YES NO

Load Carrying Capacity Modification Label (if attached) information:

Distance label is from vehicle placard (must be no more than 25 mm):

_____ mm

Label letter height (must be at least 2.4 mm in height):

_____ mm

Load Carrying Capacity reduction:

_____ kg

Monroney Label (if attached) information:

Tire Size Listed: Front _____; Rear _____

Are the sizes of the installed tires the same as the sizes of the labeled tires?
 YES NO

16. DATA SHEETS....continued

DATA SHEET 4 (5 of 5)
VEHICLE PLACARD, TIRE INFLATION PRESSURE LABEL, AND OTHER LABELS

Separate Distributor/Dealer Optional Equipment Label (if attached):

Equipment Listed: _____

DATA INDICATES COMPLIANCE: PASS/FAIL _____

REMARKS:

RECORDED BY: _____

DATE: _____

APPROVED BY: _____

DATE: _____

16. DATA SHEETS....continued

**DATA SHEET 5 (1 of 4)
CURB WEIGHT, NORMAL LOAD WEIGHT AND MAXIMUM VEHICLE WEIGHT**

VEHICLE MAKE/MODEL/BODY STYLE: _____

VEHICLE NHTSA NO. _____ VIN: _____

LABORATORY: _____ TEST DATE: _____

Full Fluid Levels: Fuel _____ Coolant _____ Other Fluids _____ (specify)

Tire Pressures: LF _____ KPA LR _____ KPA
 RF _____ KPA RR _____ KPA

A. MEASURED CURB WEIGHT WITH INSTALLED OPTIONS AND ACCESSORIES

LF _____ KG	LR _____ KG
RF _____ KG	RR _____ KG
Front Axle _____ KG	Rear Axle _____ KG
Total Vehicle _____ KG	

B. MEASURED VEHICLE NORMAL LOAD WEIGHT

- (1) Seating Capacity from Vehicle Placard = _____
- (2) Normal Load Number of Occupants (from Table in Section 11) _____

Occupant Distribution: Front Seat- _____ Second Seat- _____
 Third Seat- _____ Fourth Seat- _____

- (3) Total Normal Occupant Load _____ KG
 [# of occupants x 68 KG per occupant]

- (4) Measured Normal Load on Axles

LF _____ KG	LR _____ KG
RF _____ KG	RR _____ KG
Front Axle _____ KG	Rear Axle _____ KG

16. DATA SHEETS....continued

DATA SHEET 5 (2 of 4)
CURB WEIGHT, NORMAL LOAD WEIGHT AND MAXIMUM VEHICLE WEIGHT

- (5) Calculated Vehicle Normal Load on the Tire
 Front Tires [measured front axle normal load/2] = _____ KG
 Rear Tires [measured rear axle normal load/2] = _____ KG
- (6) Value of 94 percent of the load rating at the vehicle manufacturer's recommended cold inflation pressure for that tire

	Front Axle	Rear Axle
Installed Tire Size	_____	_____
Load Rating at recommended cold inflation pressure	_____	_____
94% of load rating	_____	_____

Vehicle Normal Load on the Tire should not be greater than the Value of 94% of the load rating at the vehicle manufacturer's recommended cold inflation pressure

		PASS/FAIL
[(5) < (6)]	Front Tires	_____
	Rear Tires	_____

C. MEASURED VEHICLE WEIGHT WITH FULL OCCUPANT LOAD

- (1) Seating Capacity from Placard:

Total _____ Front _____ Rear _____

- (2) Full Occupant Load _____ KG
 [# of occupants x 68 KG per occupant]

- (3) Measured Vehicle Weight with Full Occupant Load

LF _____ KG	LR _____ KG
RF _____ KG	RR _____ KG

Front Axle _____ KG Rear Axle _____ KG

Total Vehicle _____ KG

16. DATA SHEETS....continued

**DATA SHEET 5 (3 of 4)
CURB WEIGHT, NORMAL LOAD WEIGHT AND MAXIMUM VEHICLE WEIGHT**

D. MEASURED VEHICLE WEIGHT WITH MAXIMUM LOAD (PLACARD)

- (1) Vehicle Capacity Weight (from placard) _____ KG
- (2) Reduced Capacity Weight if applicable _____ KG
(from Load Carrying Capacity Modification Label)
- (3) Reduced Vehicle Capacity Weight _____ KG
(subtract (2) from (1))
- (4) Full Occupant Load (from C.(2) above) _____ KG
- (5) Luggage/Cargo Load (subtract (4) from (3)) _____ KG
- (6) Measured Vehicle Maximum Load on Axles

LF _____ KG	LR _____ KG
RF _____ KG	RR _____ KG
Front Axle _____ KG	Rear Axle _____ KG
Total Vehicle _____ KG	

- (7) Calculated Vehicle Maximum Load on the Tire
 Front Tires [measured front axle maximum load/2] = _____ KG
 Rear Tires [measured rear axle maximum load/2] = _____ KG

- (8) Tire Sidewall Maximum Load Ratings

	Front	Rear
Installed Tire Size	_____	_____
Max. Load Rating on Sidewall	_____	_____

Vehicle Maximum Load on the Tire should not be greater than the Maximum Load Rating Marked on the Tire Sidewall.

	Pass/Fail	
[(7) < (8)] Front Tires		_____
Rear Tires		_____

16. DATA SHEETS....continued

DATA SHEET 5 (4 of 4)
CURB WEIGHT, NORMAL LOAD WEIGHT AND MAXIMUM VEHICLE WEIGHT

(9) Tire Load Ratings at Vehicle Placard or Tire Inflation Pressure Label
 Recommended Cold Tire Inflation Pressure.

	Front Axle	Rear Axle
Labeled Tire Size	_____	_____
Labeled Cold Inflation Pressure	_____	_____
Load Rating at This Pressure*	_____	_____

*Reference used to obtain Load Rating: _____

Vehicle Normal Load on the Tire should not be greater than the Tire Load Rating at the Labeled Cold Tire Inflation Pressure.

		PASS/FAIL
[B(5) < D(9)]	Front Tires	_____
	Rear Tires	_____

Vehicle Maximum Load on the Tire should not be greater than the Tire Load Rating at the Labeled Cold Tire Inflation Pressure.

		PASS/FAIL
[D(7) < D(9)]	Front Tires	_____
	Rear Tires	_____

DATA INDICATES COMPLIANCE: PASS/FAIL _____

REMARKS:

RECORDED BY: _____ DATE: _____

APPROVED BY: _____ DATE: _____

16. DATA SHEETS....continued

DATA SHEET 6 (1 of 2)
DEFLATED TIRE RETENTION

VEHICLE MAKE/MODEL/BODY STYLE:

VEHICLE NHTSA NO. _____ VIN: _____

LABORATORY: _____ TEST DATE: _____

Tire Pressures: LF _____ KPA LR _____ KPA
RF _____ KPA RR _____ KPA

Test Weight: LF _____ KG LR _____ KG
RF _____ KG RR _____ KG
Front Axle _____ KG Rear Axle _____ KG

Total Vehicle _____ KG

Retention Test Left Front:

Odometer (START): _____ Fuel Level: _____

Ambient Temperature: _____ °C Wind Speed: _____ m/s

Vehicle Speed at time of blow-out: _____ kmph

Maximum Deceleration Rate: _____ m/sec² Deflation Opening Size: _____ cm (dia.)

Stopping Distance (Distance traveled after initial release of air): _____ m

Distance of Uncontrolled Deviation from a straight line: _____ cm

Description of Bead Separation, Outboard:

Description of Bead Separation, Inboard:

Vehicle stopped with a controlled brake application (driver opinion): () YES () NO

Deflated tire retained on rim for duration of test: () YES () NO

16. DATA SHEETS....continued

DATA SHEET 6 (2 of 2)
DEFLATED TIRE RETENTION

Retention Test Right Rear:

Odometer (START): _____ Fuel Level: _____

Ambient Temperature: _____ °C Wind Speed: _____ m/s

Vehicle Speed at time of blow-out: _____ kmph

Maximum Deceleration Rate: _____ m/sec² Deflation Opening Size: _____ cm (dia.)

Stopping Distance (Distance traveled after initial release of air): _____ m

Distance of Uncontrolled Deviation from a straight line: _____ cm

Description of Bead Separation, Outboard:

Description of Bead Separation, Inboard:

Vehicle stopped with a controlled brake application (driver opinion): () YES () NO

Deflated tire retained on rim for duration of test: () YES () NO

DATA INDICATES COMPLIANCE:		PASS/FAIL
	LEFT FRONT	_____
	RIGHT REAR	_____

REMARKS:

RECORDED BY: _____

DATE: _____

APPROVED BY: _____

DATE: _____

16. DATA SHEETS....continued

**DATA SHEET 7 (1 of 2)
OWNER'S MANUAL REQUIREMENTS**

VEHICLE MAKE/MODEL/BODY STYLE:

VEHICLE NHTSA NO. _____

VIN: _____

LABORATORY: _____

TEST DATE: _____

Owner's Manual Discusses:

Part 575.6(a) Paragraph	Required Discussion Topic	Discussed in Manual? (YES/NO)
(4)(i)	Tire labeling, including a description and explanation of each marking on the tires provided with the vehicle, and information about the location of the Tire Identification Number (TIN).	
(4)(ii)	(A) Description and explanation of recommended cold tire inflation pressure.	
	(B) Description and explanation of FMVSS 110 Vehicle Placard and Tire Inflation Pressure Label and their location(s).	
	(C) Description and explanation of adverse safety consequences of under-inflation including tire failure.	
	(D) Description and explanation for measuring and adjusting air pressure to achieve proper inflation.	
(4)(iii)	Glossary of tire terminology, including "cold tire pressure," maximum inflation pressure," and "recommended inflation pressure," and all non-technical terms defined in S3 of FMVSS 110 & 139.	
(4)(vi)	Tire care, including maintenance and safety practices.	
(4)(v)	(A) Description and explanation of locating and understanding load limit information, total load capacity, seating capacity, towing capacity, and cargo capacity.	
	(B) Description and explanation for calculating total and cargo load capacities with varying seating configurations including quantitative examples showing/illustrating how the vehicle's cargo and luggage capacity decreases as the combined number and size of occupants increases.	
	(C) Description and explanation for determining compatibility of tire and vehicle load capabilities.	
	(D) Description and explanation of adverse safety consequences of overloading on handling and stopping and on tires.	

17. FORMS

LABORATORY NOTICE OF TEST FAILURE TO OVSC

FMVSS NO.: 110 TEST DATE: _____

LABORATORY: _____

CONTRACT NO.: _____ DELV. ORDER NO.: _____

LABORATORY PROJECT ENGINEER'S NAME: _____

TEST SPECIMEN DESCRIPTION: _____

VEHICLE NHTSA NO.: _____ VIN: _____

MFR: _____

TEST FAILURE DESCRIPTION: _____

FMVSS REQUIREMENT, PARAGRAPH S _____:

NOTIFICATION TO NHTSA (COTR): _____

DATE: _____ BY: _____

REMARKS:

17. FORMS...Continued

MONTHLY TEST STATUS REPORT
FMVSS 110
DATE OF REPORT:

NO.	VEHICLE NHTSA NO., MAKE & MODEL	COMPLIANCE TEST DATE	PASS/ FAIL	DATE REPORT SUBMITTED	DATE INVOICE SUBMITTED	INVOICE PAYMENT DATE
1						
2						
3						
4						
5						
6						
7						
8						
9						
10						

17. FORMS...Continued

MONTHLY VEHICLE STATUS REPORT
FMVSS 110
DATE OF REPORT:

NO.	VEHICLE NHTSA NO., MAKE & MODEL	DATE OF DELIVERY	ODOMETER READING	TEST COMPLETE DATE	VEHICLE SHIPMENT DATE	ODOMETER READING
1						
2						
3						
4						
5						
6						
7						
8						
9						
10						