

U.S. DEPARTMENT OF TRANSPORTATION
NATIONAL HIGHWAY TRAFFIC SAFETY ADMINISTRATION
LABORATORY TEST PROCEDURE
FOR
FMVSS No. 136
Electronic Stability Control Systems for Heavy Vehicles



ENFORCEMENT
Office of Vehicle Safety Compliance
Mail Code: NEF-240
1200 New Jersey Avenue, SE
Washington, DC 20590

REVISION CONTROL LOG
FOR OVSC LABORATORY
TEST PROCEDURES

TP-136
 Electronic Stability Control Systems for
 Heavy Vehicles

TEST PROCEDURE		FMVSS No. 136		DESCRIPTION
REV. No.	DATE	AMENDMENT	EFFECTIVE DATE	
00	2-10-16	80 FR36105	-----	Final Rule

OVSC LABORATORY TEST PROCEDURE NO. 136

TABLE OF CONTENTS

	Page
1. PURPOSE AND APPLICATION	4
2. GENERAL REQUIREMENTS	5
3. SECURITY	7
4. GOOD HOUSEKEEPING	7
5. TEST SCHEDULING AND MONITORING	7
6. TEST DATA DISPOSITION	8
7. GOVERNMENT FURNISHED PROPERTY (GFP).....	9
8. CALIBRATION OF TEST INSTRUMENTS	10
9. PHOTOGRAPHIC DOCUMENTATION	11
10. DEFINITIONS	12
11. PRETEST REQUIREMENTS.....	14
12. COMPLIANCE TEST EXECUTION	17
13. POSTTEST DATA PROCESSING.....	24
14. REPORTS.....	26
15. FORMS	37

APPENDIX A - DATA SHEETS

APPENDIX B - FABRICATING AND INSTALLING ROLLOVER SAFETY EQUIPMENT

APPENDIX C - J-TURN MANEUVER TESTS – LOGIC TREE DIAGRAMS

1. PURPOSE AND APPLICATION

This document is a laboratory test procedure provided by the National Highway Traffic Safety Administration (NHTSA), Office of Vehicle Safety Compliance (OVSC) for the purpose of presenting guidelines for a uniform testing data and information recording format, and providing suggestions for the use of specific equipment and procedures for contracted testing laboratories. The data correspond to specific requirements of the Federal Motor Vehicle Safety Standard(s) (FMVSS). The OVSC test procedures include requirements that are general in scope to provide flexibility for contracted laboratories to perform compliance testing and are not intended to limit or restrain a contractor from developing or utilizing any testing techniques or equipment which will assist in procuring the required compliance test data. These test procedures do not constitute an endorsement or recommendation for use of any particular product or testing method.

Prior to conducting compliance testing, contracted laboratories are required to submit a detailed test procedure to the Contracting Officer's Representative (COR) to demonstrate concurrence with the OVSC laboratory test procedure and the applicable FMVSS. If any contractor views any part of an OVSC laboratory test procedure to be in conflict with a FMVSS or observes deficiencies in a laboratory test procedure, the contractor is required to advise the COR and resolve the discrepancy prior to the start of compliance testing or as soon as practicable. The contractor's test procedure must include a step-by-step description of the methodology and detailed check-off sheets. Detailed check-off sheets shall also be provided for the testing instrumentation including a complete listing of the test equipment with make and model numbers. The list of test equipment shall include instrument accuracy and calibration dates. All equipment shall be calibrated in accordance with the manufacturer's instructions. There shall be no contradictions between the laboratory test procedure and the contractor's in-house test procedure. Written approval of the in-house test procedures shall be obtained from the COR before initiating the compliance test program.

NOTE: The OVSC Laboratory Test Procedures, prepared for the limited purpose of use by independent laboratories under contract to conduct compliance tests for the OVSC, are not rules, regulations or NHTSA interpretations regarding the meaning of a FMVSS. The laboratory test procedures are not intended to limit the requirements of the applicable FMVSS(s). In some cases, the OVSC laboratory test procedures do not include all of the various FMVSS minimum performance requirements. Recognizing applicable test tolerances, the laboratory test procedures may specify test conditions that are less severe than the minimum requirements of the standard. In addition, the laboratory test procedures may be modified by the OVSC at any time without notice, and the COR may direct or authorize contractors to deviate from these procedures, as long as the tests are performed in a manner consistent with the standard itself and within the scope of the contract. Laboratory test procedures may not be relied upon to create any right or benefit in any person. Therefore, compliance of a vehicle or item of motor vehicle equipment is not necessarily guaranteed if the manufacturer limits its certification tests to those described in the OVSC laboratory test procedures.

2. GENERAL REQUIREMENTS

Federal Motor Vehicle Safety Standard No.136 requires that truck tractors and large buses (see page 6, Exemptions) with a gross vehicle weight rating (GVWR) of greater than 11,793 kilograms (26,000 pounds) manufactured for sale in the United States be equipped with an Electronic Stability Control (ESC) System with the following attributes (S4);

- (a) augments vehicle directional stability by applying and adjusting the vehicle brake torques individually at each wheel position on at least one front and at least one rear axle of the vehicle to induce correcting yaw moment to limit vehicle over-steer and to limit vehicle understeer;
- (b) enhances rollover stability by applying and adjusting the vehicle brake torques individually at each wheel position on at least one front and at least one rear axle of the vehicle to reduce lateral acceleration of a vehicle;
- (c) computer-controlled with the computer using a closed-loop algorithm to induce correcting yaw moment and enhance rollover stability;
- (d) determines the vehicle's lateral acceleration;
- (e) determines the vehicle's yaw rate and to estimate its side slip or side slip derivative with respect to time;
- (f) estimates vehicle mass or, if applicable, combination vehicle mass;
- (g) monitors driver steering inputs;
- (h) modifies engine torque, as necessary, to assist the driver in maintaining control of the vehicle;
- (i) When installed on a truck tractor, provides brake pressure to automatically apply and modulate the brake torques of a towed trailer;

System Operational Capabilities (S5.2)

The vehicle's ESC system must be operational over the full speed range of the vehicle except;

- (a) At vehicle speeds less than 20 km/h (12.4 mph)
- (b) When driven in reverse
- (c) During ESC system initialization

The vehicle's ESC must remain capable of activation even if the ABS or traction control is also activated.

Engine Torque Reduction (S5.3.2)

When subjected to the J-Turn maneuver performance test, the vehicle's ESC system must reduce driver requested engine torque by at least 10 percent for a minimum continuous duration of 0.5 seconds during the time period from 1.5 seconds after the vehicle crosses the start gate (0 degree arc angle) to when it crosses the end gate (120 degrees of radius arc angle).

Roll Stability and Control (S5.3.3)

When subjected to the J-Turn maneuver performance test, the vehicle's ESC system must apply and adjust vehicle brake torques individually at each wheel position on at least one front and at least one rear axle to reduce the vehicle's longitudinal velocity to no greater than;

- (a) 47 km/h (29 mph) measured at 3.0 seconds after the vehicle passes through the start gate and;
- (b) 45 km/h (28 mph) measured at 4.0 seconds after the vehicle passes through the start gate

ESC System Malfunction Detection (S5.4)

The vehicle shall be equipped with an ESC system malfunction warning indicator that is;

- (a) Mounted in front of and in clear view of the driver
- (b) Displayed and identified in accordance with 49CFR 571.101
- (c) Activated whenever there is a malfunction that affects the generation or transmission of control or response signals in the vehicle's ESC system
- (d) Activated as a check lamp function when the ignition is in a designated check position
- (e) Extinguished at the next ignition cycle after a malfunction has been corrected

Exemptions:

The following truck tractors and buses are exempt from the standard's requirements:

- (a) Any truck tractor or bus equipped with an axle that has a gross axle weight rating (GAWR) of 29,000 pounds or more;
- (b) Any truck tractor or bus that has a speed attainable in 2 miles of not more than 33 mph;
- (c) Any truck tractor that has a speed attainable in 2 miles of not more than 45 mph, an unloaded vehicle weight that is not less than 95 percent of its gross vehicle weight rating (GVWR), and no capacity to carry occupants other than the driver and operating crew;
- (d) Any bus with fewer than 16 designated seating positions (including the driver);
- (e) Any bus with fewer than 2 rows of passenger seats that are rearward of the driver's seating position and are forward-facing or can convert to forward-facing without the use of tools;
- (f) School buses
- (g) Any urban transit buses sold for operation as a common carrier in urban transportation along a fixed route with frequent stops.

3. SECURITY

The contractor shall provide appropriate security measures to protect the OVSC test vehicles and Government Furnished Property (GFP) from unauthorized personnel during the entire compliance testing program. The contractor is financially responsible for any acts of theft and/or vandalism which occur during the storage of test vehicles and GFP. Any security problems which arise shall be reported by telephone to the Industrial Property Manager (IPM), Office of Acquisition Management, within two working days after the incident. A letter containing specific details of the security problem shall be sent to the IPM (with copy to the COR) within 48 hours.

The contractor shall protect and segregate the data that evolves from compliance testing before and after each vehicle test. No information concerning the vehicle safety compliance testing program shall be released to anyone except the COR, unless specifically authorized by the COR or the COR's Division Chief.

NOTE: No individuals, other than contractor personnel directly involved in the compliance testing program or OVSC personnel, shall be allowed to witness any vehicle or equipment item compliance test or test dummy calibration unless specifically authorized by the COR.

4. GOOD HOUSEKEEPING

Contractors shall maintain the entire vehicle compliance testing area, test fixtures and instrumentation in a neat, clean and painted condition with test instruments arranged in an orderly manner consistent with good test laboratory housekeeping practices.

5. TEST SCHEDULING AND MONITORING

The contractor shall submit a test schedule to the COR prior to conducting the first compliance test. Tests shall be completed at intervals as required in the contract. If not specified, the first test shall be conducted within 6 weeks after receiving the first delivered unit. Subsequent tests shall be completed in no longer than 1 week intervals unless otherwise specified by the COR.

Scheduling of tests shall be adjusted to permit vehicles (or equipment, whichever applies) to be tested to other FMVSSs as may be required by the OVSC. All compliance testing shall be coordinated with the COR in order to allow monitoring by the COR or other

OVSC personnel if desired. The contractor shall submit a monthly test status report and a vehicle status report (if applicable) to the COR. The vehicle status report shall be submitted until all vehicles are disposed of. The status report forms are provided in the forms section.

6. TEST DATA DISPOSITION

The Contractor shall make all vehicle preliminary compliance test data available to the COR on location within 30 minutes after the test. Final test data, including digital printouts and computer generated plots (if applicable) shall be available to the COR in accordance with the contract schedule or if not specified within two working days. Additionally, the Contractor shall analyze the preliminary test results as directed by the COR.

All backup data sheets, strip charts, recordings, plots, technicians' notes, etc., shall be either sent to the COR or destroyed at the conclusion of each delivery order, purchase order, etc.

TEST DATA LOSS

A. INVALID TEST DESCRIPTION

An invalid compliance test is one, which does not conform precisely to all requirements/specifications of the OVSC Laboratory Test Procedure and Statement of Work applicable to the contract.

B. INVALID TEST NOTIFICATION

The Contractor shall notify NHTSA of any test not meeting all requirements/specifications of the OVSC Laboratory Test Procedure and Statement of Work applicable to the test, by telephone, within 24 hours of the test and send written notice to the COR within 48 hours of the test completion.

C. RETEST NOTIFICATION

The Contracting Officer of NHTSA is the only NHTSA official authorized to notify the Contractor that a retest is required. The retest shall be completed within 2 weeks after receipt of notification by the Contracting Officer that a retest is required.

D. WAIVER OF RETEST

NHTSA, in its sole discretion, reserves the right to waive the retest requirement. This provision shall not constitute a basis for dispute over the NHTSA's waiving or not waiving any requirement.

7. GOVERNMENT FURNISHED PROPERTY (GFP)

GFP consist of test vehicles, test equipment and instrumentation. The GFP is authorized by contractual agreement. The contractor is responsible for the following.

A. ACCEPTANCE OF TEST VEHICLES

The contractor has the responsibility of accepting each GFP test vehicle whether delivered by a new vehicle dealership or another vehicle transporter. In both instances, the contractor acts on behalf of the OVSC when signing an acceptance of the GFP test vehicle delivery order. When a GFP vehicle is delivered, the contractor must verify:

1. All options listed on the "window sticker" are present on the test vehicle.
2. Tires and wheel rims are new and the same as listed.
3. There are no dents or other interior or exterior flaws in the vehicle body.
4. The vehicle has been properly prepared and is in running condition.
5. The glove box contains an owner's manual, warranty document, consumer information, and extra set of keys.
6. Proper fuel filler cap is supplied on the test vehicle.
7. Spare tire, jack, lug wrench and tool kit (if applicable) is located in the vehicle cargo area.
8. The VIN (vehicle identification number) on the vehicle condition report matches the VIN on the vehicle.
9. The vehicle is equipped as specified by the COR.

A Vehicle Condition form will be supplied to the contractor by the COR when the test vehicle is transferred from a new vehicle dealership or between test contracts. The upper half of the form is used to describe the vehicle as initially accepted. The lower half of the Vehicle Condition form provides space for a detailed description of the post-test condition. The contractor must complete a Vehicle Condition form for each vehicle and deliver it to the COR with the Final Test Report or the report will NOT be accepted for payment.

If the test vehicle is delivered by a government contracted transporter, the contractor shall check for damage which may have occurred during transit. GFP vehicle(s) shall not be driven by the contractor on public roadways unless authorized by the COR.

B. NOTIFICATION OF COR

The COR must be notified within 24 hours after a vehicle (and/or equipment item) has been delivered. In addition, if any discrepancy or damage is found at the time of delivery, a copy of the Vehicle Condition form shall be sent to the COR immediately.

8. CALIBRATION OF TEST INSTRUMENTS

Before the contractor initiates the safety compliance test program, a test instrumentation calibration system will be implemented and maintained in accordance with established calibration practices. The calibration system shall include the following as a minimum:

- A. Standards for calibrating the measuring and test equipment shall be stored and used under appropriate environmental conditions to assure their accuracy and stability.
- B. All measuring instruments and standards shall be calibrated by the Contractor, or a commercial facility, against a higher order standard at periodic intervals not exceeding 12 months for instruments and 12 months for the calibration standards except for static types of measuring devices such as rulers, weights, etc., which shall be calibrated at periodic intervals not to exceed two years. Records, showing the calibration traceability to the National Institute of Standards and Technology (NIST), shall be maintained for all measuring and test equipment.
- C. Inertial sensing systems shall be calibrated every twelve months or after a test failure or after any indication from calibration checks that there may be a problem with the inertial sensing systems whichever occurs sooner.
- D. All measuring and test equipment and measuring standards shall be labeled with the following information:
 - 1. Date of calibration
 - 2. Date of next scheduled calibration
 - 3. Name of the technician who calibrated the equipment
- E. A written calibration procedure shall be provided by the Contractor, which includes as a minimum the following information for all measurement and test equipment:
 - 1. Type of equipment, manufacturer, model number, etc.
 - 2. Measurement range
 - 3. Accuracy
 - 4. Calibration interval
 - 5. Type of standard used to calibrate the equipment (calibration traceability of the standard must be evident).
 - 6. The actual procedures and forms used to perform the calibrations.

- F. Records of calibration for all test instrumentation shall be kept by the Contractor in a manner that assures the maintenance of established calibration schedules.
- G. All such records shall be readily available for inspection when requested by the COR. The calibration system shall need the acceptance of the COR before vehicle safety compliance testing commences.
- H. Test equipment shall receive a system functional check out using a known test input immediately before and after the test. This check shall be recorded by the test technician(s) and submitted with the final report.
- I. The Contractor may be directed by NHTSA to evaluate its data acquisition system.

Further guidance is provided in the International Standard ISO 10012-1, "Quality Assurance Requirements for Measuring Equipment" and American National Standard ANSI/NCSL Z540-1, "Calibration Laboratories and Measuring and Test Equipment - General Requirements."

NOTE: In the event of a failure to meet the standard's minimum performance requirements, additional calibration checks of some critically sensitive test equipment and instrumentation may be required for verification of accuracy. The necessity for the calibration will be at the COR's discretion and will be performed without additional cost.

9. PHOTOGRAPHIC DOCUMENTATION

9.1 COLOR DIGITAL VIDEO

Capture video footage (pan view) of each J-Turn maneuver test run, including the outer edges of the lane, with a High Definition (HD) color digital video camcorder that has a minimum display resolution, scanning system and frames per second of 720p 60HZ. Transfer the video footage to a compact disc (CD) or digital video disc (DVD) as AVI or MPEG files with standard or generally available "codec."

For the first 5 second segment in the video footage of each run, display the following information;

TEST RUN No.____ - Roll Stability & Control Test (i.e., type of test)
 FMVSS No. 136 Compliance Test
 Test Vehicle: Model Year, Make and Model
 NHTSA No. CXXXXXXXXX
 Test Laboratory:
 Test Date:

9.2 DIGITAL PHOTOGRAPHS

Photographs shall be taken in color and contain clear images. A tag, label or placard identifying the test vehicle, NHTSA number and date shall appear in each photograph and be legible. Each photograph shall be labeled as to the subject matter. The required resolution for digital photographs is a minimum of 1,600 x 1,200 pixels. Digital photographs are required to be created in color and in a JPG format. Glare or light from any illuminated or reflective surface shall be minimized while taking photographs.

At a minimum, include the following photographs in each final test report:

1. Frontal Views of Test Vehicle *
2. Left Side Views of Test Vehicle *
3. Right Side Views of Test Vehicle *
4. Rear Side Views of Test Vehicle *
5. Close-up Views of Vehicle's Certification Label(s)
6. Close-up Views of Vehicle's Tire Placard Label(s)
7. Drive and Steer Axle Brake Chambers
8. Drive and Steer Axle Foundation Brake Linings with Thermocouples Installed
9. Speed Measurement Device installed on the Test Vehicle
10. Interior View of the Test Vehicle Cab with Instrumentation and Ballast Installed
11. Close-up View of Test Vehicle's Dash showing ESC Malfunction Telltale
12. Close-up Views of the rollover safety equipment installed on the test vehicle

*(unloaded and loaded to GVWR)

10. DEFINITIONS (S4)

ACKERMAN STEER ANGLE

The angle whose tangent is the wheelbase divided by the radius of the turn at a very low speed.

ESC SERVICE BRAKE APPLICATION

The ESC system applies service brake pressure at any wheel for a continuous duration of at least 0.5 second of at least 34 kPa (5 psi) for air-braked systems and at least 172 kPa (25 psi) for hydraulic-braked systems.

INITIAL BRAKE TEMPERATURE (IBT)

The average temperature of the service brakes on the hottest axle of the vehicle immediately before any stability control system test maneuver is executed.

LATERAL ACCELERATION

The component of the vector acceleration of a point in the vehicle perpendicular to the vehicle x axis (longitudinal) and parallel to the road plane

OVERSTEER

A condition in which the vehicle's yaw rate is greater than the yaw rate that would occur at the vehicle's speed as a result of the Ackerman Steer Angle

OVER-THE-ROAD BUS

A bus characterized by an elevated passenger deck located over a baggage compartment, except a school bus

PEAK FRICTION COEFFICIENT (PFC)

The ratio of the maximum value of braking test wheel longitudinal force to the simultaneous vertical force occurring prior to wheel lockup as the braking torque is progressively increased.

PERIMETER-SEATING BUS

A bus with 7 or fewer designated seating positions rearward of the driver's seating position that are forward-facing or can convert to forward-facing without the use of tools.

SIDE SLIP or SIDE SLIP ANGLE

The arctangent of the lateral velocity of the center of gravity of the vehicle divided by the longitudinal velocity of the center of gravity.

STOP-REQUEST SYSTEM

A vehicle-integrated system for passenger use to signal to a vehicle operator that they are requesting a stop.

SIDE SLIP OR SIDE SLIP ANGLE

The arctangent of the lateral velocity of the center of gravity of the vehicle divided by the longitudinal velocity of the center of gravity

SNUB

The braking deceleration of a vehicle from a higher speed to a lower speed that is greater than zero.

TRANSIT BUS

A bus that is equipped with a stop-request system sold for public transportation provided by, or on behalf of, a State or local government and that is not an over-the-road bus.

UNDERSTEER

A condition in which the vehicle's yaw rate is less than the yaw rate that would occur at the vehicle's speed as a result of the Ackerman Steer Angle

YAW RATE

The rate of change of the vehicle's heading angle measured in degrees/second of rotation about a vertical axis through the vehicle's center of gravity.

11. PRETEST REQUIREMENTS

Prior to conducting any compliance tests, at a minimum, the contractor shall have met the facilities and equipment requirements specified below;

A. Ambient Temperature Gauge

A gauge to record ambient test temperatures with a minimum range of 0°C (32°F) to 37.8°C (100°F) and $\pm 0.5^\circ\text{C}$ accuracy at 21°C.

B. Anemometer

An anemometer to measure wind velocity with a minimum operating range of 2 km/h to 100 km/h and an accuracy of $\pm 3\%$ of readout.

C. Brake Lining Temperature Measurement System

A temperature measurement system consisting of J-type thermocouples imbedded in the brake linings that are capable of accurately measuring brake lining temperatures with a minimum range 0°C to 700°C with an accuracy of $\pm 0.5\%$ of readout.

D. Control Trailers (S6.3.5.1)

The control trailers are unbraked, flatbed semi-trailers. Truck tractors with less than 4 axles are tested with a control trailer that has a single axle with a GAWR of 8,165 kg (18,000 lb.) and a length of at least 6400 mm (252 inches), but no more than 7010 mm (276 inches), when measured from the transverse centerline of the axle to the centerline of the kingpin (the point where the trailer attaches to the truck tractor). Truck tractors with four or more axles may be tested with a control trailer that has a maximum length of no more than 13,208

mm (520 inches) when measured from the transverse centerline of the axle to the centerline of the kingpin.

E. Data Acquisition System (DAS)

A continuous recorder capable of permanently recording (at a minimum) the following data;

1. Vehicle deceleration
2. Wheel lockup at each wheel
3. Distance and speed versus time
4. Foot Brake control (treadle valve) pressures versus time
5. Air reservoir pressures
6. Brake lining temperatures

The DAS is capable of visually displaying the data to the driver while seated in the test vehicle during burnish and J-turn maneuver tests.

F. Decelerometer

A decelerometer to measure the vehicle's deceleration rate with a minimum range of 1.0 g with 0.5 ft/s² accuracy, maximum non-linearity of ± 0.5 ft/s² over the range.

G. Fifth Wheel

Optical or mechanical fifth wheel or equivalent device, 0 -100 mph range with an accuracy of 0.5mph, distance accuracy <0.2%, maximum non-linearity of ± 1 mph over the range and visual output resolution of 0.1 mph.

H. Pressure Transducers

A sufficient number of air pressure transducers to measure air pressure at the foot brake control (treadle valve), brake chambers and air reservoirs.

I. Rollover Protection Safety Equipment (See Appendix B)

Rollover protection safety equipment consist of roll bars, outriggers and anti-jackknife systems installed on the test vehicle to ensure the safety of the driver in the event of a rollover during J-Turn maneuver tests. The test laboratory shall be capable of fabricating rollover protection safety equipment such that;

1. The roll bar and outriggers weigh no more than 453.6 kg (1,000 lb) and 1134 kg (2,500 lb), respectively. (S6.3.6)
2. The anti-jackknife system limits the articulation angle between the tractor and control trailer to no more than 30 degrees. (S6.3.8)

J. Test Track and Surface (S6.2)

The facility shall have a test track area large enough to conduct burnish and 150 foot radius J-Turn maneuver tests including area for the test vehicle to safely enter and exit the test course at the appropriate test speeds. The J-Turn maneuver test surface is a dry, uniform, solid-paved surface with a consistent slope between 0% and 1% and PFC of 0.9 when measured using an ASTM E1136-93 standard reference test tire in accordance ASTM Method E1337-90, at a speed of 64.4 km/h (40 mph), without water delivery.

K. Weighing Scales

Weighing Scales capable of weighing individual axle loads up to 13,608 kg (30,000 lb) with an accuracy of $\pm 1\%$ at full range.

12. COMPLIANCE TEST EXECUTION

12.1 Test Vehicle Preparation

A. Install brake lining thermocouples (see Figure 1)

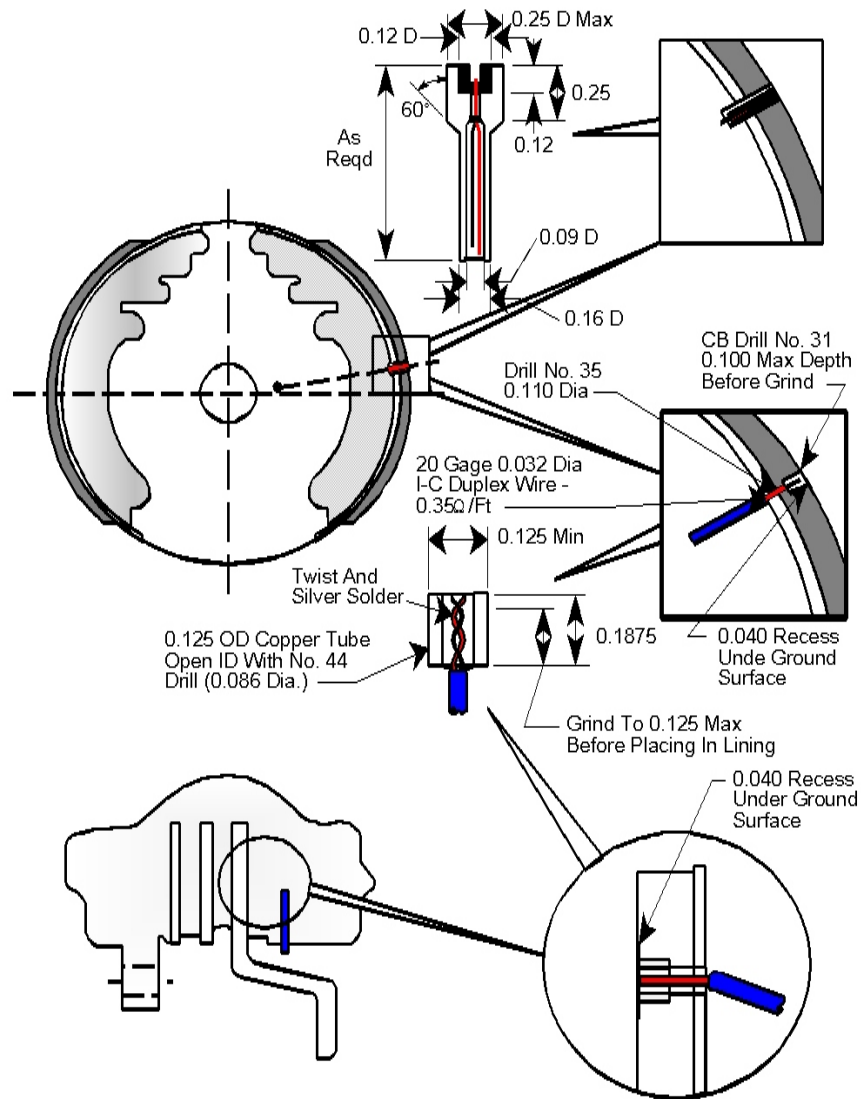

Figure 1 – Typical Plug-type Thermocouple Installation

- B. Install rollover protection safety equipment
- C. Inflate tires to manufacturer's cold tire pressure specifications
- D. Install the data acquisition system and instrumentation
 1. Install pressure transducers in each air brake chamber and in the control line at the treadle valve

2. Install wheel lockup detection system and fifth wheel (i.e., speed measurement device(s))
 3. Install readout interface to display to the driver brake temperature readings from thermocouples, pressure readings from transducers, vehicle speed and deceleration.
- E. Achieve Test Weight - GVWR (+0 - .05*GVWR)
- Achieve test weight by loading the test vehicle to its gross vehicle weight rating (GVWR) as follows:
1. Truck tractor (S6.3.3.1)

Load a truck tractor to GVWR by coupling it to a loaded control trailer such that the combined weight of the truck tractor and control trailer equals the GVWR of the truck tractor. The location of the center of gravity of the ballast on the control trailer is directly above the kingpin. The height of the center of gravity of the ballast on the control trailer is less than 610 mm (24 in.) above the top of the tractor's fifth-wheel hitch.
 2. Bus (S6.3.3.2)

Load a bus to GVWR by placing 150 lb of ballast at each designated seating position (DSP). Load additional ballast, as necessary, in the luggage compartment to achieve test weight. If the bus does not have a luggage compartment, load the bus floor with the appropriate ballast. Secure ballast to prevent excessive movement during the test runs.

12.2 Burnish the Brakes (S7.4.1.1)

- A. Make an initial adjustment to the brakes per vehicle manufacturer's recommendation. The brakes may be adjusted, as specified by the vehicle manufacturer, up to three additional times during the burnish procedure.
- B. Burnish the test vehicle's brake linings by making 500 brake snubs between 64 km/h (40 mph) and 32 km/h (20 mph).
- C. Modulate the treadle valve (brake control) to maintain an average deceleration rate of 0.3 g (10 ft/sec²) or at the vehicle's maximum deceleration rate if less than 0.3 g (10 ft/sec²) with transmission in the highest gear appropriate to achieve speed.
- D. Except where a brake adjustment is necessary, after each brake application, accelerate to 64 km/h (40 mph) and maintain that speed until making the next brake application at a point 1.6 km (1 mile) from the initial point of the previous

brake application. If the vehicle cannot attain a speed of 64 km/h (40 mph) in 1.6 km (1 mile), continue to accelerate until the vehicle reaches 40 mph or until the vehicle has reached 2.4 km (1.5 miles) from the initial point of the previous brake application, whichever occurs first.

- E. Minimize driver breaks during burnishing such that no break occurs within any 25 brake snubs sequence.
- F. At the end of every 25th brake snub, record the initial speed, IBTs, average treadle valve pressure and average deceleration.
- G. At the completion of all burnish snubs, adjust the brakes according to the vehicle manufacturer's recommendation.

12.3 Prepare the J-Turn Maneuver Test Course (S6.2.4)

- A. The test course consists of a straight entrance lane with a length of 22.9 meters (75 feet) tangentially connected to a curved lane section with a radius of 45.7 meters (150 feet) measured from the center of the lane.

For truck tractors, the lane width of the test course is 3.7 meters (12 feet). For buses, the lane width of the test course is 3.7 meters (12 feet) for the straight section and is 4.3 meters (14 feet) for the curved section.

The start gate is the tangent point on the radius (the intersection of the straight lane and the curved lane sections) and is designated as zero degrees of radius of arc angle. The end gate is the point on the radius that is 120 degrees of radius arc angle measured from the tangent point. Figure 1 shows the test course with the curved lane section configured in the counter-clockwise steering direction relative to the entrance lane. The course is also arranged with the curved lane section configured in the clockwise steering direction relative to the entrance lane.

- B. Define the course layout by marking the width of a lane (3.7 or 4.3 meters) on a 45.7 meter (150 foot) radius arc angle. Place vertical markers (e.g., cones) at evenly spaced intervals along the outer and inner edges of the lane for the first 120 degrees of radius arc angle.
- C. Distinguish in color, height or markings the vertical markers placed at the Start Gate and End Gate of the course from the other vertical markers used along the edge of the lane.
- D. Place vertical markers to define a 22.9 meters (75 foot) entry lane tangential to the 45.7 meters (150 foot) radius at the Start Gate (see Figure 2). Install a detection system capable of signaling time zero (T0) the instant the center of the vehicle's front tires crosses the Start Gate.

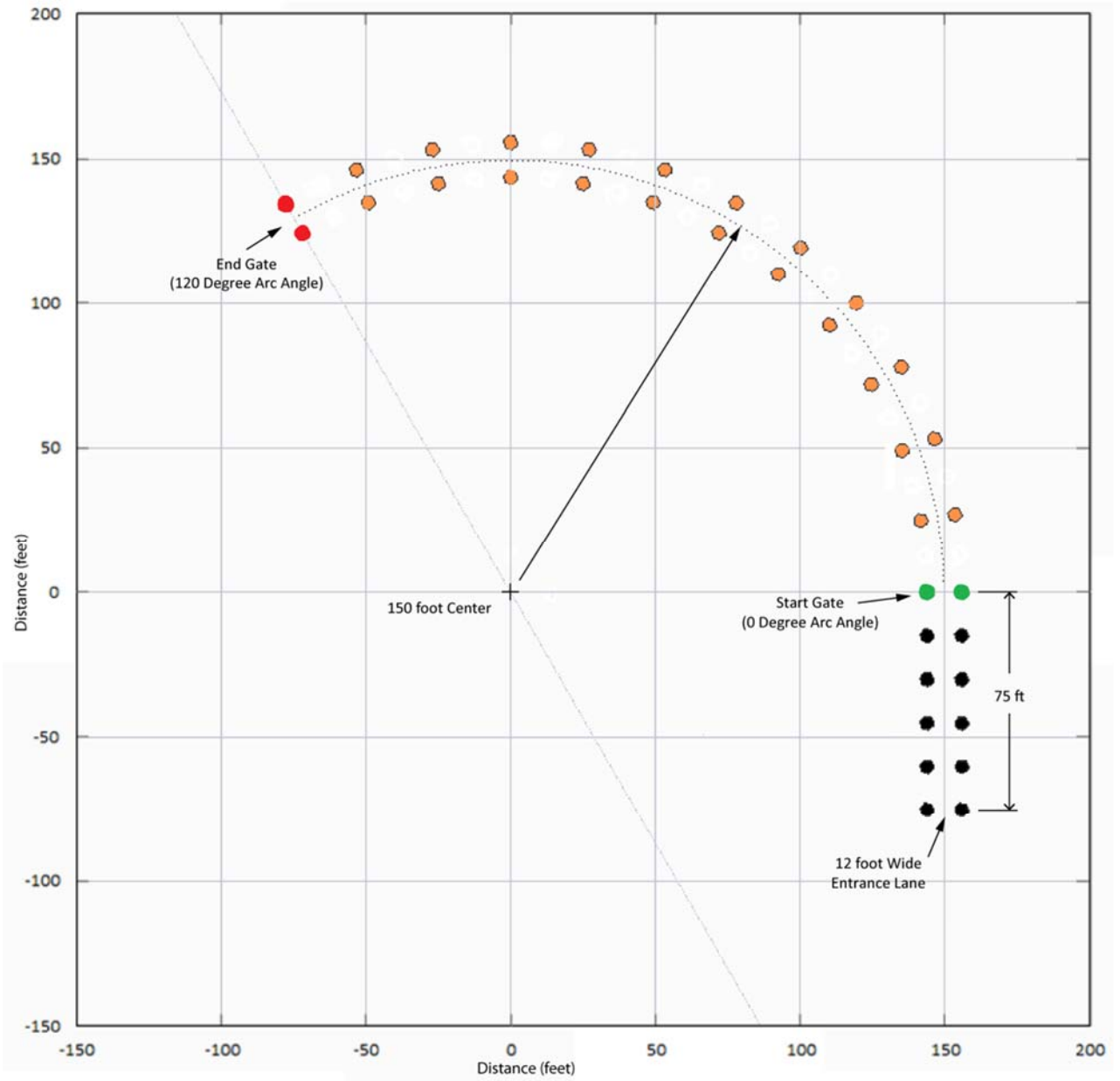

Figure 2 - J-Turn Maneuver Test Course (counter-clockwise)

12.4 ESC Malfunction Telltale and Malfunction Detection Tests (S5.4 & S7.8)

- A. Describe the location of the ESC malfunction telltale and verify that it is mounted inside the occupant compartment in front of and in clear view of the driver (S5.4).
- B. Verify that the malfunction telltale symbol or abbreviation is as specified in Table 1 of FMVSS No. 101. Make note of any additional symbols, words or messages used that correspond to the ESC malfunction indication. Make note if telltale is also used to indicate activation of the ESC system. (S.5.4.2)
- C. With the vehicle stationary and the starting system in the “Lock” or “Off” position, activate the starting system to the “On” (“Run”) position where the engine is not running, and verify that the ESC system performs a check of the malfunction and if provided the “ESC OFF” telltale lamp functions. Document the position(s) of the starting system where the ESC malfunction telltale and “ESC OFF” telltale (if equipped) illuminate. The telltale(s) shall be yellow in color and illuminate for a short period of time and then extinguish. Document the color of the illuminated telltale(s). Measure and record the time the telltale(s) remain illuminated. If the telltale(s) do not illuminate and are not displayed in a common space, proceed to step D. (S5.4.3)
- D. If the telltale(s) does (do) not illuminate, a starter interlock may be engaged. The telltale(s) need not activate as a check of the lamp function when a starter interlock is in operation. Review the vehicle Owner’s Manual to determine if the vehicle is equipped with any starter interlocks (most common interlock designs are between the starting system/vehicle starter and the brake pedal and/or transmission). Disengage the interlock and repeat step C above. Describe any interlock features that affect the check of the telltale lamp function(s). (S5.4.4)
- E. With vehicle power-off, simulate an ESC system malfunction by disconnecting the power source to the ESC system control module. (Do not disconnect the telltale lamp(s)). (S7.8.1)
- F. With the vehicle initially stationary and the starting system in the “Lock” or “Off” position, activate the starting system to the “Start” position and start the engine. If the malfunction telltale did not illuminate when engine was started, put the vehicle in a forward gear and obtain a vehicle speed of 48 ± 8 km/h (30 ± 5 mph). Drive the vehicle for at least two minutes including at least one left and one right turning maneuver, and at least one service brake application. Verify that within two minutes of obtaining this vehicle speed the ESC malfunction indicator illuminates. Document other telltales and/or warning messages. (S7.8.2)
- G. Stop the vehicle and deactivate the starting system to the “Off” or “Lock” position. After a five minute period, activate the vehicle starting system to the “Start”

position and start the engine. Verify that the ESC malfunction indicator again illuminates to signal a malfunction and that it remains illuminated for as long as the engine is running. (S7.8.3)

- H. Restore the ESC system to normal operation in accordance with manufacturer provided guidelines. Repeat paragraph B. above and verify that the malfunction telltale extinguishes. (S7.8.4)

12.5 Mass Estimation Cycle (S7.5)

Conduct the mass estimation cycle by driving the test vehicle in accordance with the vehicle manufacturer's instructions provided by the COR.

12.6 Ambient Temperature (S6.1.1)

The ambient temperature is between 2° C (35 °F) and 40 °C (104 °F).

12.7 Wind Speed (S6.1.2)

The maximum wind speed is no greater than 5 m/s (11 mph).

12.8 Vehicle Conditions (S6.3)

1. Verify the ESC is enabled by ensuring that the ESC malfunction indicator telltale does not remain illuminated after ignition "On" ("Run") (S6.3.1 & S7.6)
2. Place all doors, windows and hoods in the closed position. (S6.3.2)
3. Disengage manually controlled engine brake retarders. (S6.3.4)
4. Disengage manually controlled interlocking axle systems and front wheel drive systems (S6.3.9)
5. Place lift-able axle(s) in the down-position (S6.3.10)

12.9 Tire Conditioning (S7.3)

Drive the test vehicle in a 150 ft radius circle at a speed that produces a lateral acceleration of approximately 0.1g for 2 clockwise laps followed by 2 counterclockwise laps.

12.10 Brake Conditioning (S7.4.1.2)

Condition the brakes by applying 40 brake snubs from a speed of 64 km/h (40 mph) to a speed of 32 km/h (20 mph), with a target deceleration of approximately 0.3g. After each brake application, accelerate to 64 km/h (40 mph) and maintain that speed until making the next brake application at a point 1.6 km (1.0 mile) from the initial point of the previous brake application.

12.11 Initial Brake Temperatures (IBTs) (S6.3.11 & S7.4.2)

Prior to each J-Turn maneuver test run, measure and record IBTs. Verify that each IBT is within the temperature range of 66°C (150 °F) to 204°C (400 °F).

12.12 J-Turn Maneuver Test Runs

A. Determine the Preliminary Reference Speed (S7.7.1.1)

The vehicle is subjected to two series of test runs using the J-Turn test maneuver at increasing entrance speeds. One series uses clockwise steering, and the other series uses counterclockwise steering. The entrance speed of a test run is the 0.5 second average of the raw speed data prior to any ESC system activation of the service brakes and rounded to the nearest 1.0 mph. During each test run, the driver attempts to maintain the selected entrance speed throughout the J-Turn test maneuver. For the first test run of each series, the entrance speed is 32 km/h \pm 1.6 km/h (20 mph \pm 1.0 mph) and is incremented 1.6 km/h (1.0 mph) for each subsequent test run until ESC service brake application occurs or any of the truck tractor's or bus's wheels departs the lane. The vehicle entrance speed at which ESC service brake application occurs is the Preliminary Reference Speed. The Preliminary Reference Speed is determined for each direction: clockwise steering and counter-clockwise steering. During any test run, if any of the wheels of the truck tractor or bus depart the lane at any point within the first 120 degrees of radius arc angle, the test run is repeated at the same entrance speed. If any of the wheels of the truck tractor or bus depart the lane again, then four consecutive test runs are repeated at the same entrance speed (\pm 1.6 km/h (\pm 1.0 mph)).

B. Determine the Reference Speed (S7.7.1.2)

Using the Preliminary Reference Speed determined in S7.7.1.1, perform two series of test runs using the J-Turn test maneuver to determine the Reference Speed. The first series consists of four consecutive test runs performed using counter-clockwise steering. The second series consists of four consecutive test runs performed using clockwise steering. During each test run, the driver attempts to maintain a speed equal to the Preliminary Reference Speed throughout the J-Turn test maneuver. The Reference Speed is the minimum entrance speed at which ESC service brake application occurs for at least two of four consecutive test runs of each series conducted at the same entrance speed (within \pm 1.6 km/h (\pm 1.0 mph)). The Reference Speed is determined for each direction: clockwise steering and counter-clockwise steering. If ESC service brake application does not occur during at least two test runs of either series, the Preliminary Reference Speed is increased by 1.6 km/h (1.0 mph), and the procedure in this section is repeated.

C. Engine Torque Reduction Test (S7.7.2).

The vehicle is subjected to two series of test runs using the J-Turn test maneuver at an entrance speed equal to the Reference Speed determined in S7.7.1.2. One series uses clockwise steering, and the other series uses counter-clockwise steering. Each series consists of four test runs with the vehicle at an entrance speed equal to the Reference Speed and the driver fully depressing the accelerator pedal from the time when the vehicle crosses the start gate until the vehicle reaches the end gate. ESC engine torque reduction is confirmed by comparing the engine torque output and driver requested torque data collected from the vehicle communication network or CAN bus. During the initial stages of each maneuver the two torque signals with respect to time will parallel each other. Upon ESC engine torque reduction, the two signals will diverge when the ESC system causes a commanded engine torque reduction and the driver depresses the accelerator pedal attempting to accelerate the vehicle.

Perform two series of test runs using the J-Turn test maneuver at the Reference Speed determined in S7.7.1.2 (± 1.6 km/h (± 1.0 mph)). The first series consists of four consecutive test runs performed using counter-clockwise steering. The second series consists of four consecutive test runs performed using clockwise steering. During each test run, the driver fully depresses the accelerator pedal from the time when the vehicle crosses the start gate until the vehicle reaches the end gate. (S7.7.2.1)

During each of the engine torque reduction test runs, verify the commanded engine torque and the driver requested torque signals diverge (S7.7.2.2)

D. Roll Stability Control Test (S7.7.3)

The vehicle is subjected to multiple series of test runs using the J-Turn test maneuver in both the clockwise and the counter-clockwise direction.

Before each test run, the brake temperatures are monitored and the hottest brake is confirmed to be between 66 °C (150 °F) and 204 °C (400 °F). If the hottest brake temperature is not between 66 °C (150 °F) and 204 °C (400 °F), the brake temperature is adjusted in accordance with S7.4.2. (S7.7.3.1)

During each test run, the driver will release the accelerator pedal after the ESC system has slowed vehicle by more than 4.8 km/h (3.0 mph) below the entrance speed. (S7.7.3.2)

The maximum test speed is the greatest of 130 percent of the Reference Speed or 48 km/h (30 mph). The maximum test speed is determined for each direction: clockwise steering and counter-clockwise steering. (S7.7.3.3)

13. POST TEST DATA PROCESSING

A. Event Time Measurement and Time Zero (S7.9.4)

Record data continuously from at least 1 second prior to the test vehicle reaching the start gate, with the vehicle travelling at constant speed within the 75 foot entrance lane of the J-Turn test course, until the test vehicle reaches the end gate. Time zero is the instant the center of the front tires of the vehicle crosses the Start Gate.

B. Vehicle Speed Data (S7.9.1)

All raw vehicle speed data is filtered with a 0.1 second running average filter.

C. Engine Torque Data (S7.9.2 & S7.9.3)

1. Engine torque data is collected from the vehicle communication network or CAN bus. If the data recorded from the vehicle communication network or CAN bus is digital, it does not require filtering. Analog data is filtered with a 0.1 second running average filter
2. The activation point of the ESC system engine torque reduction is the instant the measured driver demanded torque and the engine torque first begin to deviate from one another (engine torque decreases while the driver requested torque increases) during the Engine Torque Reduction Test. The torque values are obtained directly from the vehicle communication network or CAN bus. Torque values used to determine the activation point of the ESC engine torque reduction are interpolated.

D. Service Brake Pressure Data (S7.9.5)

Raw service brake pressure measurements are zeroed (calibrated). Zeroed brake pressure data are filtered with 0.1 second running average filters. Zeroed and filtered brake pressure data are dynamically offset corrected using a defined "zeroed range". The "zeroing range" is defined as the 0.5 second time period prior to "time zero"

14. REPORTS

14.1. MONTHLY STATUS REPORT

The contractor shall submit a Monthly Status Report to the COR that includes all information contained in the sample report found in Section 15, Report Forms.

14.2. NOTICE OF TEST FAILURE

Any indication of a test failure shall be communicated by telephone to the COR within 24 hours with written notification mailed within 48 hours (Saturdays and Sundays excluded). A Notice of Test Failure report form with a copy of preliminary test data plot(s) shall be included. In the event of a test failure, a post test calibration check of some critically sensitive test equipment and instrumentation may be required for verification of accuracy. The necessity for the calibration shall be at the COR's discretion and shall be performed without additional costs to the OVSC.

14.3 FINAL TEST REPORTS

14.3.1 COPIES

In the case of an apparent test failure, two (2) paper copies and three (3) electronic copies in pdf formats of the Final Test Report shall be submitted to the COR for acceptance within three weeks of test completion. The Final Test Report format to be used by all contractors can be found in the "Report Section".

Where there has been no indication of an apparent noncompliance, one (1) paper copy and two (2) electronic copies in pdf formats of each Final Test Report shall be submitted to the COR for acceptance within three weeks of test completion. No payment of contractor's invoices for conducting compliance tests will be made prior to the Final Test Report acceptance by the COR. Contractors are requested to NOT submit invoices before the COR is provided with copies of the Final Test Report.

Contractors are required to submit the first Final Test Report in draft form within one week after the compliance test is conducted. The contractor and the COR will then be able to discuss the details of both test conduct and report content early in the compliance test program.

Contractors are required to PROOF READ all Final Test Reports before submittal to the COR. The OVSC will not act as a report quality control office for contractors. Reports containing a significant number of errors will be returned to the contractor for correction, and a "hold" will be placed on invoice payment for the particular test.

14.3.2 REQUIREMENTS

Each final report must be a complete document capable of standing by itself. The contractor should use DETAILED descriptions of all compliance test events. Any events that are not directly associated with the standard but are of technical interest should also be included. The contractor should include as much DETAIL as possible in the report.

Instructions for the preparation of the first three pages of the final test report are provided for standardization.

14.3.3 FIRST THREE PAGES

A. FRONT COVER

A heavy paperback cover (or transparency) shall be provided for the protection of the final report. The information required on the cover is as follows:

- (1) Final Report Number such as 136-ABC-XX-001, where –

- 136 is the FMVSS tested
- ABC are the initials for the laboratory
- XX is the last two numbers of the Fiscal Year of the test program
- 001 is the Group Number (001 for the 1st test, 002 for the 2nd test, etc.)

- (2) Final Report Title and Subtitle such as;

SAFETY COMPLIANCE TESTING FOR FMVSS
 FMVSS No. 136
 Electronic Stability Control
 Systems
 * * * * *
 ABC Motor
 Company
 20XX Saferider Bus
 NHTSA No.
 C20XXXXXX

(3) Contractor's Name and Address such as;

123 TESTING LABORATORIES, INC.
4335 West Dearborn St.
Detroit, Michigan 48090-1234

NOTE: DOT SYMBOL SHALL BE PLACED BETWEEN ITEMS (3) AND (4)

- (4) Date of Final Report completion
- (5) The words "FINAL REPORT"
- (6) The sponsoring agency's name and address as follows

U. S. DEPARTMENT OF TRANSPORTATION
National Highway Traffic Safety Administration
Enforcement
Office of Vehicle Safety Compliance
Mail Code: NEF-240
1200 New Jersey Avenue, SE
Washington, DC 20590

B. FIRST PAGE AFTER FRONT COVER

When a contract test laboratory is reporting, a disclaimer statement and an acceptance signature block for the COR shall be provided as follows:

This publication is distributed by the National Highway Traffic Safety Administration in the interest of information exchange. Opinions, findings and conclusions expressed in this publication are those of the author(s) and not necessarily those of the Department of Transportation or the National Highway Traffic Safety Administration. The United States Government assumes no liability for its contents or use thereof.

If trade or manufacturers' names or products are mentioned, it is only because they are considered essential to the object of the publication and should not be construed as an endorsement.

Prepared By: _____

Approved By: _____

Approval Date: _____

FINAL REPORT ACCEPTANCE BY OVSC:

Accepted By: _____

Acceptance Date: _____

C. SECOND PAGE AFTER FRONT COVER

A completed Technical Report Documentation Page (Form DOT F1700.7) shall be completed for those block items that are applicable with the other blocks left blank. Sample data for the applicable block numbers of the title page follows.

Block 1 — REPORT NUMBER

136-ABC-XX-001

Block 2 — GOVERNMENT ACCESSION

NUMBER Leave blank

Block 3 — RECIPIENT'S CATALOG

NUMBER Leave blank

Block 4 — TITLE AND SUBTITLE

Final Report of FMVSS 136 Compliance Testing
of 20XX Saferider Bus, NHTSA No. C20XXXXXX

Block 5 — REPORT

DATE Month
Day, 20XX

Block 6 — PERFORMING ORGANIZATION

CODE 123

Block 7 — AUTHOR(S)

John Smith, Project Manager
Bill Doe, Project Engineer

Block 8 — PERFORMING ORGANIZATION REPORT

NUMBER ABC-DOT-XXX-001

Block 9 — PERFORMING ORGANIZATION NAME AND ADDRESS

123 Laboratories
405 Main Street
Detroit, MI 48070-1234

Block 10 — WORK UNIT NUMBER

Leave blank

Block 11 — CONTRACT OR GRANT NUMBER

DTNH22-XX-D-12345

Block 12 — SPONSORING AGENCY NAME AND ADDRESS

United States Department of Transportation
National Highway Traffic Safety Administration
Office of Vehicle Safety Compliance
Mail Code: NEF-240
1200 New Jersey Avenue, SE
Washington, DC 20590

Block 13 — TYPE OF REPORT AND PERIOD COVERED

Final Test Report
Month Day to Month Day, 20XX

Block 14 — SPONSORING AGENCY CODE

NVS-220

Block 15 — SUPPLEMENTARY NOTES

Leave Blank

Block 16 — ABSTRACT

Compliance tests were conducted on a 20XX Saferider Bus in accordance with the specifications of the Office of Vehicle Safety Compliance Test Procedure No. TP-136-0X. The tests were conducted November XX through November XX, 20XX. The test results indicate the following;

Test	Result
ESC Malfunction Telltale Tests	PASS
Preliminary Reference Speed Test	PASS
Reference Speed Test	PASS
Engine Torque Reduction Test	PASS
Roll Stability Control Test	PASS

Block 17 — KEY WORDS

Compliance Testing
 Electronic Stability Control System
 FMVSS No. 136

Block 18 — DISTRIBUTION STATEMENT

Copies of this report are available from;

National Highway Traffic Safety Administration
 Technical Information Services Division, NPO-411
 1200 New Jersey Avenue SE (Room E12-100)
 Washington DC 20590
 e-mail: tis@nhtsa.dot.gov
 FAX: 202-493-2833

Block 19 — SECURITY CLASSIFICATION OF REPORT

Unclassified

Block 20 — SECURITY CLASSIFICATION OF PAGE

Unclassified

Block 21 — NUMBER OF PAGES

Add appropriate number

Block 22 — PRICE

Leave blank

D. REPORT FORMAT

The final test report consists of a table of contents, Section 1, Section 2 and Appendices as follows;

TABLE OF CONTENTS

<u>Section</u>		<u>Page No.</u>
1	Purpose of the Compliance Test	1
2	Test Data Summary	3
	Data	
	<u>Sheet No.</u>	
	1 Test Vehicle Specifications	3
	2 Test Weight	..
	3 ESC Malfunction Telltale and Malfunction Detection	..
	4 Burnish Data	..
	5 Preliminary Reference Speed Determination Data	..
	6 Reference Speed Determination Data	..
	7 Engine Torque Reduction Data	..
	8 Roll Stability Control Data	..
	9 Test Vehicle Accelerometer Locations	..
	10 Test Vehicle Accelerometer Data Summary	..
	11 MDB Accelerometer Locations and Data Summary	..
	12 MDB Summary of Results	..
	13 Dummy Injury Response Data For ES-2re	..
	14 Dummy Injury Response Data For SID-IIs	..
	<u>Appendix</u>	
I	Photographs	I -1
II	Data Plots	II -1

NOTE: This section should be double-spaced and requires an entire separate page.

SECTION 1
PURPOSE OF THE COMPLIANCE TEST

PURPOSE

This section briefly outlines the purpose for conducting the compliance test and states the appropriate test procedure(s) followed during the test. The following is provided as an example;

This compliance test is part of the FY__ FMVSS 136 Heavy Vehicle ESC Compliance Test Program sponsored by the National Highway Traffic Safety Administration (NHTSA), under contract No. _____. The purpose of this test is to generate data that will assist NHTSA in determining whether the test vehicle meets the performance requirements of FMVSS No. 136. The compliance test was conducted in accordance with the Office of Vehicle Safety Compliance's Laboratory Test Procedure (TP-136-0X, dated _____, 20XX).

SUMMARY

A 20XX SafeRider Bus was equipped with a (Mfr., model#) electronic stability control system. Rollover safety equipment was installed on the test vehicle. New foundation brake linings with thermocouples imbedded in the linings to measure IBT's were installed. The brake linings were burnished November XX thru November XX, 20XX. J-Turn maneuver tests were conducted in the counter-clockwise and clockwise directions November XX, 20XX thru November XX, 20XX. Digital video of the test runs and photographs documenting the conduct of the tests are part of this report.

SECTION 2
TEST DATA SUMMARY

This section includes all data sheets (See Appendix A).

APPENDIX I
PHOTOGRAPHS

The following photographs shall be included in this appendix;

TABLE OF PHOTOGRAPHS

No.	Description	Page
1	Frontal View Test Vehicle (Unloaded)	I-1
2	Frontal View of Test Vehicle (Loaded)	I-2
3	Left-Side View of Test Vehicle (Unloaded)	I-3
4	Left-Side View of Test Vehicle (Loaded)	..
5	Right Side View of Test Vehicle (Unloaded)	..
6	Right Side View of Test Vehicle (Loaded)	..
7	Rear Side View of Test Vehicles (Unloaded)	..
8	Rear Side View of Test Vehicles (Loaded)	..
9	Close-up View of the Vehicle's Certification Label(s)	..
10	Close-up View of the Vehicle's Tire Placard Label(s)	..
11	Steer Axle Brake Chambers	..
12	Drive Axle Brake Chambers	..
13	Steer Axle Brake Linings with Thermocouples Installed	..
14	Drive Axle Brake Linings with Thermocouples Installed	..
15	Speed Measurement Device Installed on the Test Vehicle	..
16	Interior View of the Test Vehicle Cab with Instrumentation Installed	..
17	Close-up View of Test Vehicle's Dash showing ESC Malfunction Telltale	..
18	XXXX	..

APPENDIX II
Test Data Plots

As a minimum, the following data plots shall be included in this appendix:

TABLE OF DATA PLOTS
FILTERED DATA

No.	Description	Page
1	Preliminary Reference Speed (PRS)_Test Run No.1_Speed (mph) vs. time(s)	II-1
2	Preliminary Reference Speed (PRS)_Test Run No.1_Pressure (psi) vs time(s)	II-2
3	Preliminary Reference Speed (PRS)_Test Run No.1_Temp.(F) vs. time(s)	II-3
4	Reference Speed _Test Run No.1_ Speed (mph) vs. time(s)	..
5	Reference Speed _Test Run No.1_ Pressure (psi) vs. time(s)	..
6	Reference Speed _Test Run No.1_ Temp. (F) vs. time(s)	..
7	Reference Speed _Test Run No.1_ Speed (mph) vs. time(s)	..
8	Reference Speed _Test Run No.1_ Speed (mph) vs. time(s)	..
9	Reference Speed _Test Run No.1_ Speed (mph) vs. time(s)	..
10	Reference Speed _Test Run No.1_ Speed (mph) vs. time(s) Reference Speed _Test Run No.1_ Speed (mph) vs. time(s)	..
11	Steer Axle Brake Chambers Reference Speed _Test Run No.1_ Speed (mph) vs. time(s)	..
12	Drive Axle Brake Chambers	..
13	Steer Axle Brake Linings with Thermocouples Installed	..
14	Drive Axle Brake Linings with Thermocouples Installed	..
15	Speed Measurement Device Installed on the Test Vehicle	..
16	Interior View of the Test Vehicle Cab with Instrumentation Installed	..
17	Close-up View of Test Vehicle's Dash showing ESC Malfunction Telltale	..
18	XXXX	..

16. FORMS

LABORATORY NOTICE OF TEST FAILURE TO OVSC

FMVSS NO.: _____ TEST DATE: _____

LABORATORY: _____

CONTRACT NO.: _____ DELV. ORDER NO.: _____

PROJECT ENGINEER: _____

NHTSA NO.: _____ VIN: _____

MFR: _____

TEST FAILURE DESCRIPTION: _____

FMVSS REQUIREMENT, PARAGRAPH S _____:

NOTIFICATION TO NHTSA (COR): _____ DATE:

COMMENTS: _____

MONTHLY STATUS REPORT

FMVSS No. 136

Contract Number: _____ Fiscal Year: _____ Laboratory: _____ Report Date: _____

No.	NHTSA No.	Date Of Delivery	Initial Odometer Reading	Test Dates	Pass Or Fail	Date of Final Report	Invoice No.	Invoice Date	Final Odometer Reading	Date Vehicle Is Disposed
1										
2										
3										
4										
5										
6										
7										
8										
9										
10										

Intentionally Blank