

require between 4–8 days and when empty the SRV would disconnect from the buoy and leave the port.

Initially it is expected that Port Dolphin would be capable of a natural gas throughput of 400 mmscfd and would eventually be capable of 800 mmscfd with a peak capacity of 1200 mmscfd by having at least one SRV regasifying and discharging at all times. The system would be designed so that two SRVs can be moored simultaneously for continuous unloading of natural gas.

Port Dolphin Energy LLC is seeking Federal Energy Regulatory Commission (FERC) approval for the onshore pipelines concurrent with this deepwater port application. As required by FERC regulations, FERC will also maintain a docket for the FERC portion of the project. The docket numbers are CP07–191–000 and CP07–192–000. The filing may also be viewed on the web at <http://www.ferc.gov> using the “eLibrary” link. Enter the docket number excluding the last three digits in the docket number field to access the document. For assistance, call (866) 208–3767 or TYY, (202) 502–8659.

In addition, pipelines and structures such as the moorings may require permits under Section 404 of the Clean Water Act and Section 10 of the Rivers and Harbors Act which are administered by the Army Corps of Engineers (USACE).

Port Dolphin will also require permits from the Environmental Protection Agency (EPA) pursuant to the provisions of the Clean Air Act, as amended, and the Clean Water Act, as amended.

The new pipeline will be included in the National Environmental Policy Act (NEPA) review as part of the deepwater port application process. FERC, EPA, and the USACE among others, are cooperating agencies and will assist in the NEPA process as described in 40 CFR 1501.6; will be participating in the scoping meetings; and will incorporate the EIS into their permitting processes. Comments sent to the FERC docket, EPA or USACE will also be incorporated into the DOT docket and EIS to ensure consistency with the NEPA Process.

Construction of the deepwater port would be expected to take approximately 22 months with startup of commercial operations following construction, should a license be issued. The deepwater port would be designed, constructed and operated in accordance with applicable codes and standards.

#### Privacy Act

The electronic form of all comments received into the DOT docket are

available to any person and may be searched by the name of the individual submitting the comment (or signing the comment, if submitted on behalf of an association, business, labor union, etc.). You may review DOT’s complete Privacy Act Statement in the **Federal Register** published on April 11, 2000 (Volume 65, Number 70; Pages 19477–78) or you may visit <http://dms.dot.gov>. (Authority: 49 CFR 1.66)

Dated: June 20, 2007.

By Order of the Maritime Administrator.

**Daron T. Threet,**

*Secretary, Maritime Administration.*

[FR Doc. E7–12243 Filed 6–22–07; 8:45 am]

**BILLING CODE 4910–81–P**

## DEPARTMENT OF TRANSPORTATION

### National Highway Traffic Safety Administration

[Docket No. NHTSA–2007–28067]

#### Highway Safety Programs; Model Specifications for Calibrating Units for Breath Alcohol Testers; Conforming Products List of Calibrating Units for Breath Alcohol Testers

**AGENCY:** National Highway Traffic Safety Administration (NHTSA), DOT.

**ACTION:** Notice.

**SUMMARY:** This notice amends the Model Specifications for Calibrating Units for Breath Alcohol Testers (Model Specifications) by adopting an alternate test procedure for evaluating the accuracy of both wet bath and dry gas breath alcohol calibrating units infra-red spectroscopy, as proposed in the **Federal Register** on August 13, 1997 (62 FR 43416). Published with this notice is an updated Conforming Products List of Calibrating Units for Breath Alcohol Testers (CPL) of calibrating units that meet the Model Specifications. This updated CPL includes 22 new listings—8 wet bath units and 14 dry gas units.

**DATES:** *Effective Date:* The amendments to the Model Specifications and the issuance of the CPL become effective on June 25, 2007.

**FOR FURTHER INFORMATION CONTACT:** *For technical issues:* Ms. J. De Carlo Ciccel, Office of Behavioral Safety Research, NTI–130, National Highway Traffic Safety Administration, 1200 New Jersey Avenue, SE., Washington, DC 20590; Telephone (202) 366–1694. *For legal issues:* Ms. Allison Rusnak, Office of Chief Counsel, NCC–113, National Highway Traffic Safety Administration, 1200 New Jersey Avenue, SE., Washington, DC 20590; Telephone (202) 366–1834.

**SUPPLEMENTARY INFORMATION:** On August 18, 1975 (40 FR 36167), NHTSA published a standard for Calibrating Units for Breath Alcohol Testers. A Qualified Products List of calibrating units for breath alcohol testers that met the standard was first issued on November 30, 1976 (41 FR 53389).

On December 14, 1984, NHTSA issued a notice to convert the mandatory standards for calibrating units for breath alcohol testers to Model Specification for such devices (49 FR 48865) and to establish a Conforming Products List (CPL) of calibrating units meeting the Model Specifications. Calibrating units provide known concentrations of ethanol vapor for the calibration or calibration checks of instruments that measure breath alcohol (BrAC).

On December 29, 1994, NHTSA published a notice amending the Model Specifications and updating the CPL for calibrating units (59 FR 67377). The notice also proposed and sought comments about providing an alternate test procedure using National Institute for Standards and Technology (NIST) Reference Gas Mixtures for evaluating the accuracy and precision of dry-gas ethanol calibrating units. The agency amended the Model Specifications on August 13, 1997 by incorporating the NIST test procedure (62 FR 43416). In that same notice, NHTSA updated the CPL and proposed an alternate test procedure for evaluating the accuracy and precision for evaluating wet bath and dry gas calibrating units using infra-red spectroscopy.

Having received no comments regarding the infra-red spectroscopy test procedure, this notice adopts the alternate procedure for evaluating wet bath and dry gas calibrating units using infra-red spectroscopy as proposed. This notice also amends the CPL of Calibrating Units for Breath Alcohol Testers, adding 8 wet bath units and 14 dry gas units.

#### A. Procedures for a Product Submission

Testing of calibrating units submitted by manufacturers to these Model Specifications will continue to be conducted by the DOT Volpe National Transportation Systems Center (VNTSC). Tests will continue to be conducted semi-annually or as necessary. Manufacturers wishing to submit calibrating units for testing must apply to NHTSA for a test date (Office of Behavioral Safety Research, NTI–130, 1200 New Jersey Avenue, SE., Washington, DC 20590, Telephone (202) 366–1694). Normally, at least 30 days will be required from the date of notification until the test can be scheduled. One week prior to the

scheduled initiation of the test program, the manufacturer shall deliver at least one unit of the device to be tested to: VNTSC, RTV-4F, 55 Broadway, Cambridge, MA 02142. The manufacturer shall be responsible for ensuring that the unit is operating properly. If the manufacturer wishes to submit a duplicate, backup unit, it may do so.

When a manufacturer delivers a device to be tested, it shall also deliver to VNTSC specifications and drawings that fully describe the unit and the Operator's Manual and Maintenance Manual normally supplied with purchase of the equipment. NHTSA will consider claims of confidentiality under 49 CFR Part 512.

The manufacturer shall also deliver the instructions that will accompany the device when it is sold. The instructions shall include information about the procedures to be followed to protect against possible condensation that might occur as a result of freezing during shipment and to correct for atmospheric pressure. The instructions shall also include information about any offsets that may apply to the use of a particular type of breath tester. NHTSA will examine these instructions to ensure that they provide sufficient information about these matters. Products submitted without this information will not be tested.

The manufacturer will have the right to check the calibrating unit between arrival at VNTSC and the start of the test and to ensure that the calibrating unit is in proper working condition. The manufacturer will have no access to the calibrating unit during the tests. Any malfunction of the calibrating unit that results in failure to complete any of the tests satisfactorily will result in a finding that it does not conform to the Model Specifications. If a unit fails to conform, it may be resubmitted for testing after appropriate corrective action has been taken.

On the basis of these results, NHTSA periodically will publish a CPL identifying the calibrating units that conform to the Model Specifications.

Re-testing of units will be conducted when necessary. NHTSA intends to modify and improve these Model Specifications as new data and improved test procedures become available. (The test procedures may be altered in specific instances, if necessary, to meet the unique design features of a calibrating unit). If these Model Specifications are modified, notification will be provided in the **Federal Register**. If NHTSA determines that re-testing to the modified specifications is necessary, a

manufacturer whose equipment is listed on the CPL will be notified to resubmit the equipment for testing to the modified specifications only.

NHTSA reserves the right to test any unit on the CPL throughout its useful life to ensure that the unit is performing in accordance with the Model Specifications. If at any time a manufacturer plans to change the design of a calibrating unit currently on the CPL, the manufacturer shall submit the proposed changes to the NHTSA Office of Behavioral Safety Research for review. Based on this review, NHTSA will decide whether the change will require re-testing of the unit. Normally, such re-testing will be accomplished the next time testing is performed.

Guidance to manufacturers on considerations governing this decision is available from NHTSA upon request.

NHTSA's Office of Behavioral Safety Research will be the point of contact for information about acceptance testing and field performance of equipment already on the list. NHTSA requests that users of calibrating units provide both acceptance and field performance data to NHTSA when such data is available. Information from users will be used to: (1) Help NHTSA determine whether units continue to perform according to the Model Specifications, and (2) ensure that field use does not indicate excessive breakdown or maintenance problems.

If information gathered indicates that a device on the CPL is not performing in accordance with the Model Specifications or demonstrates problems involving the device, NHTSA will direct VNTSC to conduct a special investigation. This investigation may include visits to users and additional tests of the unit obtained from the open market. If the investigation indicates that the units actually sold on the market are not meeting the Model Specifications, then the manufacturer will be notified that the unit may be removed from the CPL. The manufacturer shall have 30 days from the date of notification to reply.

Based on the VNTSC investigation and any data provided by the manufacturer, NHTSA will decide whether the unit should remain on the CPL. Upon resubmission, the manufacturer must submit a statement describing what has been done to overcome the problems that led to the removal of the unit in question from the CPL.

## B. Infra-Red Spectroscopy

This notice incorporates into the Model Specifications an alternate procedure for evaluating wet bath and

dry gas calibrating units using infra-red spectroscopy. When infra-red spectroscopy is used, the wet bath or dry gas sample to be analyzed is passed into a chamber through which infra-red radiation is transmitted. The wavelength of the transmitted radiation is chosen so that some of it is absorbed by alcohol. According to the Beer-Lambert Law of absorption of radiation,<sup>1</sup> the amount of energy absorbed by the sample in the chamber is proportional to the concentration of the alcohol in the sample. By measuring the amount of radiation transmitted when the sample chamber is empty and the amount transmitted when the sample is present, the concentration of the alcohol in the sample can be determined.

The agency believes that use of infra-red spectroscopy offers important advantages. First, the technique can be used to evaluate both wet bath calibrating units and dry gas calibrating units because surface interactions do not affect the analysis. Second, standards used in the evaluations can be prepared at VNTSC, eliminating the necessity of obtaining standards from an outside source.

## C. Conforming Products List

The CPL, which appears as an Appendix to this notice, lists the calibrating units that have been re-tested to date at the lower BACs (*i.e.*, at 0.020, 0.040, 0.080, and 0.160) and found to conform to the Model Specifications reprinted herein. The CPL also lists devices that have not been tested at the lower BAC levels (.020, .040, .080 and .160), but were listed on the CPL for calibrating units on the basis that they were tested and found to conform to the earlier Model Specifications (49 FR 48864) when tested at BAC levels 0.050, 0.100 and 0.150. These devices are identified on the CPL with an asterisk.

The CPL published today includes 22 new listings—8 wet bath units and 14 dry gas units. The wet bath units include: CALWAVE dt-100, submitted by Davtech Analytical Service, Canada; Model 10-4D, Model 10-4D Revision A, Model 2100 (aka: Model 210021), Model 2100 Revision A, and 590 submitted by Guth Laboratories, Inc., Harrisburg, Pennsylvania; Alcotest CU 34 submitted by National Draeger, Inc., Durango, Colorado; and Model 3402C-2K submitted by RepCo Marketing, Inc., Raleigh, North Carolina. The dry gas units<sup>2</sup> include: 103 ppm/108L and 270

<sup>1</sup> Farrington Daniels & Robert Alberty, "Physical Chemistry" 3d. Ed. John Wiley & Sons, New York, 1996.

<sup>2</sup> The naming convention of the dry gas units added to the CPL today is illustrative of the ethanol

ppm/30L submitted by Airgas, Inc., (previously know as Gateway Airgas, Inc., A.G. Specialty Gas Co., or Acetylene Gas Co) St. Louis, Missouri; 115 ppm/34L, 115 ppm/103L, 230 ppm/34L, 230 ppm/103L, 260.5 ppm/58L, 260.5 ppm/537L, and 260.5 ppm/15L submitted by Air Liquide, CALGAZ, Cambridge, Maryland; and Scotty 28 0.040 BAC/28L, 0.045 BAC/28L, 0.080 BAC/28L, 0.100 BAC/28L, 0.105 BAC/28L submitted by Scott Specialty Gases, Inc., Plumsteadville, Pennsylvania. One device, Toxitest Model ABS120 by Federal Signal Corporation, is being removed from the CPL as it is no longer manufactured.

In consideration of the foregoing, NHTSA amends the Model Specifications for Calibrating United as set forth below.

### Model Specifications for Calibrating United for Breath Alcohol Testers

#### 1.0 Purpose and Scope

These specifications establish performance criteria and methods for testing of calibrating units which provide known concentrations of ethanol vapor for the calibration or calibration checks of breath alcohol testers. The results of this testing are intended for use in the conformance testing for the maintenance of a Conforming Products List for calibrating units.

#### 2.0 Definitions

2.1 Conformance testing. Testing to check the conformance of a product with these model specifications in advance of and independent of any specific procurement action.

2.2 Concentration units. Blood alcohol concentration: grams alcohol per 100 milliliters blood or grams alcohol per 210 liters of breath in accordance with the Uniform Vehicle Code, Section 11-903(a)(5).<sup>3</sup> BrAC is often used to indicate that the measurement is a breath measurement, i.e. grams alcohol per 210 liters of breath.

2.3 Relative Standard Deviation (RSD). The ratio of the standard deviation (SD) of a series of measurements to the mean of the series expressed as a percentage:

$$RSD = (SD/\text{Mean}) \times 100 \text{ percent}$$

2.4 Standard Deviation (SD). A common indication of precision in the

concentration in the volume of nitrogen dry gas. Concentration is expressed in parts per million (ppm) or marketed as breath alcohol concentrations (BAC) and volume is expressed in Liters(L).

<sup>3</sup> Available from National Committee on Uniform Traffic Laws and Ordinances, 405 Church Street, Evanston, IL 60201.

measurement of the concentration of a succession of N vapor samples.

$$SD = \{\text{Sum } (X_i - X_m)^2 / (N-1)\}^{1/2}$$

Where:

$X_i$  = a single measurement result;

$X_m$  = the average of the measurements;

N = the number of measurements made in the test.

2.5 Systematic Error (SE). An indication of the accuracy of the measurement of the concentration of a succession of vapor samples.

$$SE = X_m - \text{test BrAC}$$

2.6 Least Squares Fit Calibration Curve. A Line fitted to a number of measurement pairs, one the independent value (X) and the other the dependent value (Y), over a measurement range.

The fitted line is of the form:  $Y = a + bX$ , where intercept,  $a = Y_m - bX_m$ , and slope,  $b = (\text{Sum}X_iY_i - NX_m) / (\text{Sum}X_i^2 - nX_m^2)$

#### 3.0 Tests and Requirements

If the BrAC of the CU is fixed, perform the tests at the fixed BrAC; otherwise, prepare the CU for testing at 0.08 BrAC except as otherwise required in Test 1 below. Each of the tests requires 10 measurements to the three decimal places using the test procedure specified in 3.1, 3.2, or 3.3, respectively. The CU will be operated according to the manufacturer's instructions. Unless otherwise specified, the tests will be performed in the absence of drafts and at prevailing normal laboratory temperature, humidity, and barometric pressure. Performance requirements are:  $-0.002 \text{ BrAC} \leq SE \leq +0.002 \text{ BrAC}$ ;  $RSD \leq 2\%$

Test 1. Precision and Accuracy. Test at each specified BrAC.

Test 1.1: 0.020 BrAC

Test 1.2: 0.040 BrAC

Test 1.3: 0.080 BrAC

Test 1.4: 0.160 BrAC

Test 2. Ambient Temperature. Use a temperature chamber controllable to  $\pm$  °C. Soak the CU at the specified temperature for 1 hour, being careful to prevent drafts on the device, then test at that temperature.

Test 2.1: 10 °C

Test 2.2: 30 °C

Test 3. Input Power. If the CU is powered by nominal voltages of 120 volts AC or 12 volts DC, condition the device for one half hour at the appropriate input voltage specified below, then test at that voltage. Monitor the input power with a voltmeter accurate to  $\pm 2\%$  full scale in the range used and re-adjust the voltage, if necessary. If the voltage is Ac, conduct test 3.1 and 3.2.

If the voltage is DC, conduct tests 3.3 and 3.4.

Test 3.1: 108 Volts/AC

Test 3.2: 123 Volts/AC

Test 3.3: 11 Volts/DC

Test 3.4: 15 Volts/DC

Test 4. Electrical Safety Inspection.

Examine the CU for protection of the operator from electrical shock. Examine for proper use of input power fuses, and verify that there are no exposed male connectors at high potential. Determine that overheating does not occur during operation and that undue fire hazards do not exist.

#### 3.1 Test Procedure (Original, wet-bath calibrating units)

Equipment and Supplies: *Gas Chromatograph* capable of complete resolution of ethanol in test samples, with heated gas sampling valve. *Water bath* thermostated at  $34 \text{ }^\circ\text{C} \pm 0.1 \text{ }^\circ\text{C}$ . *Glass Reference Sample Bottles (300 ml capacity or greater) with Stopper and Inlet and Outlet Air Hoses* (see Figure 1). Hoses should be about 1/8" OD Teflon tubing. *Reference Ethanol Solutions* prepared using Class A glassware and American Chemical Society reagent grade ethanol or USP grade ethanol. The purity of the ethanol used shall be compared with the National Institute of standards and Technology (NIST) Standard Reference Material for ethanol. Use the value of Harger, *et al.*, for the partition ratio for concentration of ethanol in headspace to concentration in solution at  $34 \text{ }^\circ\text{C}$ ,  $K_a/w = 0.000393^4$  to prepare two solutions which, when thermostated at  $34 \text{ }^\circ\text{C}$ , produce headspace ethanol vapor concentrations that bracket the test BrAC by no more than  $\pm 20\%$ . Small Air Pump for bubbling air through reference solutions (see Figure 1).

Step 1. Prepare the Gas Chromatograph for measurement of vapor samples. Adjust instrument temperatures, gas flows, detector, and recording device for optimum response for ethanol. Prepare the CU for use according to manufacturer's instructions.

Step 2. Fill two reference solution bottles to  $3/4$  full with above reference solutions. Insert stopper assemblies with bubble line and alcohol vapor line in place and put bottles in the water bath with water level up to the stopper. Connect air pump to bubble line. Connect alcohol vapor line to gas chromatograph sampling valve inlet fitting. Allow 1 hour for temperature equilibrium to be achieved.

<sup>4</sup> RN Harger, BB Raney, EG Bridwell, MF Kitchel J. Biol. Chem. 183, 197-213 (1950). Additional data from Harger in a private communication (see 49 FR 48869).

*Step 3.* Turn on air pump which has been pre-set to pump air through the reference solution bottle-gas chromatograph sampling assembly at a rate just sufficient to thoroughly flush the system in 10 seconds. After flushing is complete, allow the sample to relax to atmospheric pressure, then inject the reference sample onto the gas chromatograph column. In this way, obtain 5 chromatograms of one of the reference solution headspace ethanol vapors.

*Step 4.* Thoroughly flush the sample loop with vapors from the CU device,

while avoiding over-pressurizing of the sampling system. To prevent condensation of alcohol, warm the transfer line if necessary. Allow the sample to relax to atmospheric pressure, then inject the sample onto the column. In this way, obtain 10 ethanol chromatograms using the CU device.

*Step 5.* Repeat step 3 using the second reference solution.

*Step 6.* Calculations. *Peak height to BrAC conversion factor.* For each ethanol peak obtained in Step 3 and Step 5, calculate a conversion factor for ethanol concentration by dividing the

equivalent BrAC of the vapor sample by the peak height obtained for that sample. From the 10 samples, obtain the mean and the RSD of the conversion factors. If the RSD obtained fails to meet the criteria for RSD in 3.0, perform necessary troubleshooting and repeat the procedure from Step 1. Use the mean of the conversion factors to calculate the BrAC for each of the 10 ethanol peaks obtained in Step 4. Calculate the mean, the RSD, and the systematic error of the experimental BrACs.

**Figure 1. Wet Bath Reference Sample Set-up. Sample lines 1/8" Teflon. The bubble line should extend at least 4 inches below surface of the solution. The length of the alcohol vapor line from the headspace to the gas chromatograph should be minimized.**

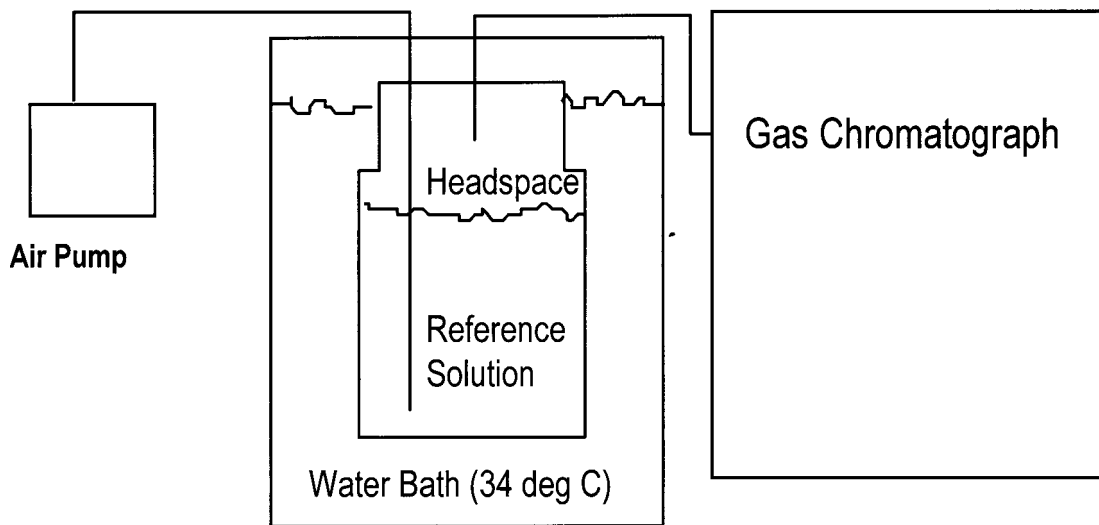

3.2 Test Procedures (for dry gas calibrating units). Alternate Test Method using National Institute of Standards and Technology Reference Gas Mixtures (NISTRGMs) in place of wet bath reference samples

The following alternate method for the evaluation of dry gaseous ethanol calibration devices is presented.

*Additional required material:* For the alternate method for evaluation of dry gaseous ethanol calibration devices, the following will be required: Four cylinders of National Institute of Standards and Technology ethanol-inert gas Technical Reference Gas Mixtures (NISTRGMs) which span the BrAC range 0.01 to 0.16.

*Alternate procedure for evaluation of dry gaseous ethanol calibration devices.* This procedure substitutes the use of NISTRGMs in place of the wet bath reference samples when evaluating dry gas CUs.

*Step A1.* Connect one of the NISTRGM cylinders to the inlet of the gas chromatograph sampling valve and pass reference gas through the sampling system at a rate just sufficient to thoroughly flush the system in about 10 seconds. Allow the sample to relax to atmospheric pressure, then inject the sample onto the column. In this way, obtain 5 chromatograms of the reference gas.

*Step A2.* Repeat Step A1 for each of the four NISTRGM reference gas mixtures.

*Step A3.* Calculate the RSD of the concentration divided by peak height data obtained in Step A1 and Step A2. If the calculated RSD meets the criteria of 3.0, calculate the slope and intercept of the least squares fit calibration line for conversion of peak height to BrAC. Using the average peak height of each NISTRGM and the slope and intercept data, calculate the concentration of each NISTRGM. If the resulting concentrations are within the stated accuracy of the NISTRGM, proceed to Step A4.

*Step A4.* Connect the calibrating device to the inlet of the gas

chromatograph sampling system and allow the calibrating device gas to flow at a rate just sufficient to thoroughly flush the sampling system in about 10 seconds. Allow the sample to relax to atmospheric pressure, then inject the sample onto the column. In this way, obtain 10 chromatograms of the calibrating device gas.

*Step A5.* Calculations. Using the peak height data obtained in Step A4 and intercept and slope data obtained in Step A3, calculate the BrAC for each of the 10 peak heights. Calculate the mean, RSD, and systematic error of the calculated BrACs.

### 3.3 Test Procedures (for dry gas or wet bath calibrating units)

This alternate procedure uses infrared spectroscopy that is suitable for evaluating ethanol vapor samples from either wet-bath CUs or from dry-gas CUs.

3.3.1 General. This method uses the Beer-Lambert Law of absorption of radiant energy by fluids.

$$I = I_0 \times e^{-abc}$$

Where:

$I_0$  is the energy entering the sample chamber of a spectrophotometer containing the sample to be analyzed.

$I$  is the energy transmitted from the sample chamber.

$a$  is the absorptivity of the sample.

$b$  is the radiation path length of the sample chamber.

$c$  is the concentration of the sample in the sample chamber.

A convenient form of the Beer-Lambert law is

$$\ln(I_0/I) = abc$$

where the term  $\ln(I_0/I)$ , the logarithm of the ratio of incident to transmitted energy, is called the absorbance of the sample. In the procedure described below, the terms  $a$  and  $b$  are treated as a single quantity,  $ab$ , and the term  $c$  is BrAC.

#### 3.3.2 Test Procedure.

Equipment and Supplies. *Infra-red Spectrophotometer* with sample chamber that can be heated to above 40 °C. A non-dispersive instrument with appropriate band pass filters and configured to measure breath alcohol

samples, such as an infra-red evidential breath tester listed on the NHTSA Conforming Products List for evidential breath testers may be used. The detector voltage of the instrument must be accessible for measurement. The sampling hoses of the device may be altered for more convenient processing of test samples. *Water bath* thermostated at 34 °C ± 0.1 °C. *Glass Reference Sample Bottles (300 ml capacity or greater) and Stoppers with Bubble and Alcohol Vapor lines* (see Figure 2).

*Reference Ethanol Solutions* prepared using Class A glassware and American Chemical Society reagent grade ethanol or USP grade ethanol. The purity of the ethanol used shall be compared with the National Institute of Standards and Technology (NIST) Standard Reference Material for ethanol. Use the value of Harger, *et al.*, for the partition ratio for concentration of ethanol in headspace to concentration in solution at 34 °C,  $K_{a/w} = 0.000393^2$  to prepare two aqueous alcohol solutions which bracket the test BrAC by no more than ± 20%. A cylinder of inert *Flushing Gas*, which is optically clear in the absorption region used for measurement. This gas will be used to flush the sample chamber of the spectrophotometer and to deliver reference headspace vapors and wet bath sample vapors into the sample chamber. *Pressure regulating valve with Teflon delivery hose* for controlling flow and delivery of flushing gas.

*Step B1.* Prepare the spectrometer for measurement of vapor samples. Prepare the CU for use according to manufacturer's instructions.

*Step B2.* Fill a reference sample bottles to ¾ full with water and two reference sample bottles to ¾ full with the above reference solutions. Insert stopper assemblies ensuring that the end of the bubble line reaches to at least 4 inches below the surface of the solution, then place the bottles in the water bath with water level up to the stopper. Allow 1 hour for temperature equilibrium to be achieved.

*Step B3.* Connect the bubble line of the sample bottle containing water only to the flushing gas valve and the vapor line to the spectrophotometer inlet and

flush the sample chamber with water vapor and obtain the detector voltage reading. Then flush the detector chamber with flushing gas only and obtain the detector reading. Repeat 2 times to obtain 3 sets of readings. If the CU being evaluated is a wet bath device, skip this step and proceed to Step B4.

*Step B4.* In the manner of Step B3, obtain 5 sets of detector readings using one of the reference alcohol solution bottles.

*Step B5.* In the manner of Step B3, obtain 10 sets of detector readings from the CU being evaluated. If the CU is a wet bath device, use the flushing gas to fill the sample chamber, operating the device according to manufacturer's instructions. If the CU device is dry gas device, fill the sample chamber according to manufacturer's instructions.

*Step B6.* Repeat Step B5 using the other reference alcohol solution bottle.

*Step B7.* Repeat Step B3.

*Step B8.* Calculations. For each measurement pair,  $I_0$  is the detector voltage obtained for the flushing gas alone in the sample chamber and  $I$  is the voltage obtained for the flushing gas with reference sample or test sample in the sample chamber corrected for water vapor absorption, i.e.; the detector voltage obtained for headspace reference samples at 0.000 BrAC. Use the average of the 6 voltage readings obtained for the water samples for the correction for water vapor absorption ( $I = I_{\text{sample}} - I_{\text{water}}$ ). In the case of wet bath device samples, there is no correction for water vapor absorption. If the detector is biased, it will be the difference between the bias voltage and the above voltage.

Calculate the absorbance for each of the 10 reference samples. Divide each absorbance by the corresponding BrAC of the sample. Obtain the mean (which is the factor  $ab$ ), SD, and RSD for the 10 ratios. If the RSD is more than 2%, troubleshoot the procedure and repeat.

Calculate the absorbance for each of the 10 CU test samples. Divide each by the  $ab$  factor to obtain the BrAC for each of the 10 CU samples. Obtain the mean, SD, RSD, and SE.

**Figure 2. Equipment set-up. Bubble and sample lines 1/8" Teflon, minimized length. Depth of bubble line into reference solution at least 4". The alcohol vapor line from the headspace to the IR spectrophotometer should be minimized.**

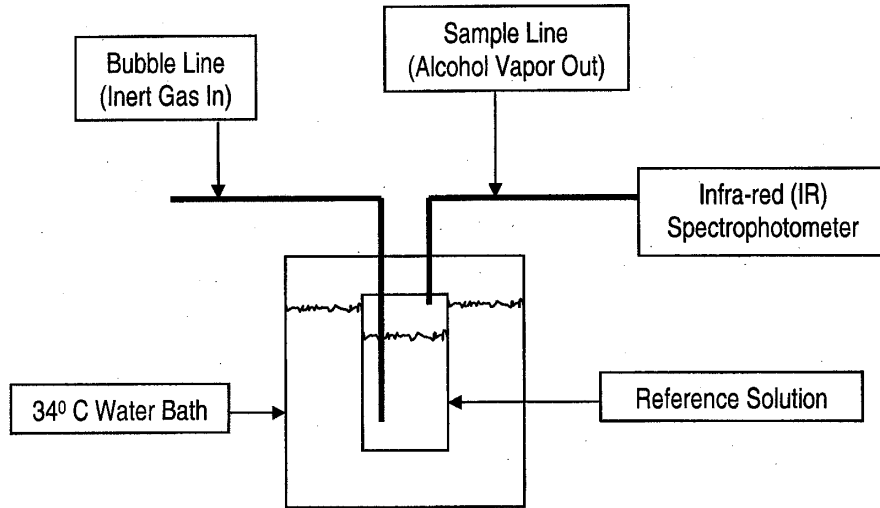

**Appendix—Conforming Products List of Calibrating Units for Breath Alcohol Testers [Manufacturer and Calibrating Unit]<sup>1</sup>**

**CONFORMING PRODUCTS LIST OF CALIBRATING UNITS FOR BREATH ALCOHOL TESTERS**

Manufacturers	Type of device	
	Dry gas	Wet bath
1. Airgas, Inc. (Formerly known as: Gateway Airgas, AG Specialty Gas, or Acetylene Gas Co.), St. Louis, MO		
• Ethanol Breath Alcohol Standard .....	X	
• 103 parts per million (ppm)/108 Liters (L) .....	X	
• 270 ppm/30L .....	X	
2. Air Liquide CALGAZ, Cambridge, MD		
• 115 ppm/34L .....	X	
• 115 ppm/105L .....	X	
• 230 ppm/34L .....	X	
• 230 ppm/105L .....	X	
• 260.5 ppm/58L .....	X	
• 260.5 ppm/537L .....	X	
• 260.5 ppm/15L .....	X	
3. CMI, Inc., Owensboro, KY		
• Toxitest II .....		X
4. Davtech Analytical Services, Canada		
• CALWAVE dT-100 .....		X
5. Guth Laboratories, Inc., Harrisburg, PA		
• Model 34C Simulator (variations: Model 34C Cal DOJ, 34-C-FM, and 34C-NPAS) .....		X
• Model 3412 .....		X
• Model 10-4 and 10-4D .....		X
• Model 10-4D Revision A .....		X
• Model 1214 .....		X
• Model 2100 (formerly Model 210021) .....		X
• Model 2100 Revision A .....		X
• 590 .....		X
6. Intoximeters, Inc., St. Louis, MO		
• Alco Breath Alcohol Standards* .....	X	
7. Lion Laboratories, Cardiff, Wales, UK (a subsidiary of CMI, Inc.)		
• AlcoCal Breath Alcohol Standard .....	X	
8. Liquid Technology Corp., Orlando, FL		
• Ethanol-in-Nitrogen .....	X	
9. Luckey Laboratories, Inc., San Bernardino, CA		
• Simulator* .....		X

<sup>1</sup> Infra-red (IR) and fuel cell breath testers may be calibrated with either wet bath or dry gas CUs.

However, it is inadvisable to use dry gas CUs when calibrating gas chromatograph EBTs.

CONFORMING PRODUCTS LIST OF CALIBRATING UNITS FOR BREATH ALCOHOL TESTERS—Continued

Manufacturers	Type of device	
	Dry gas	Wet bath
10. National Draeger, Inc., Durango, CO		
• Mark II–A .....		X
• Alcotest CU 34 .....		X
11. PLD of Florida, Inc., Rockledge, FL		
• BA 500 .....		X
12. Protection Devices, Inc., U.S. Alcohol Testing, Inc., Rancho Cucamonga, CA		
• LS34 Model 6100* .....		X
13. RepCo Marketing, Inc., Raleigh, NC		
• AS–1 .....		X
• Model 3402C .....		X
• Model 3402C–2K .....		X
14. Scott Specialty Gases, Inc., Plumsteadville, PA		
• Model EBS™ Gaseous Ethanol Breath Standard .....	X	
• Scotty 28 0.040 BAC/28L .....	X	
• Scotty 28 0.045 BAC/28L .....	X	
• Scotty 28 0.080 BAC/28L .....	X	
• Scotty 28 0.100 BAC/28L .....	X	
• Scotty 28 0.105 BAC/28L .....	X	
15. Smith & Wesson Electronic Co., Springfield, MA		
• Mark II–A Simulator* .....		X
16. Systems Innovation, Inc., Hallstead, PA		
• True-Test MD 901* .....		X
17. U.S. Alcohol Testing, Rancho Cucamonga, CA		
• Alco-Simulator 2000* .....		X
• Alco-Simulator 61000 .....		X

\*Six instruments marked with an asterisk (\*) meet the Model Specifications in 49 FR 48864 (December 14, 1984), i.e. instruments tested at 0.050, 0.100, and 0.150). Instruments not marked with an asterisk meet the model specifications detailed in this notice, and were tested at 0.020, 0.040, 0.080, and 0.160 BrAC.

**Authority:** 23 U.S.C. 402; delegations of authority at 49 CFR 1.50 and 501.

Issued on: June 25, 2007.

**Marilena Amoni,**

Associate Administrator for the Office of Research and Program Development.

[FR Doc. 07–3060 Filed 6–22–07; 8:45 am]

**BILLING CODE 4910–59–M**

**DEPARTMENT OF TRANSPORTATION**

**Surface Transportation Board**

[STB Ex Parte No. 290 (Sub–No. 5) (2007–3)]

**Quarterly Rail Cost Adjustment Factor**

**AGENCY:** Surface Transportation Board, Department of Transportation.

**ACTION:** Approval of rail cost adjustment factor.

**SUMMARY:** The Board has approved the third quarter 2007 rail cost adjustment factor (RCAF) and cost index filed by the Association of American Railroads. The third quarter 2007 RCAF (Unadjusted) is 1.197. The third quarter 2007 RCAF (Adjusted) is 0.558. The third quarter 2007 RCAF–5 is 0.531.

**DATES:** Effective Date: July 1, 2007.

**FOR FURTHER INFORMATION CONTACT:** Mac Frampton, (202) 245–0317. [Federal Information Relay Service (FIRS) for the hearing impaired: 1–800–877–8339.]

**SUPPLEMENTARY INFORMATION:**

Additional information is contained in the Board’s decision, which is available on our Web site <http://www.stb.dot.gov>. To purchase a copy of the full decision, write to, e-mail or call the Board’s contractor, ASAP Document Solutions; 9332 Annapolis Rd., Suite 103, Lanham, MD 20706; e-mail [asapdc@verizon.net](mailto:asapdc@verizon.net); phone (202) 306–4004. [Assistance for the hearing impaired is available through FIRS: 1–800–877–8339.]

This action will not significantly affect either the quality of the human environment or energy conservation.

Pursuant to 5 U.S.C. 605(b), we conclude that our action will not have a significant economic impact on a substantial number of small entities within the meaning of the Regulatory Flexibility Act.

Decided: June 19, 2007.

By the Board, Chairman Nottingham, Vice Chairman Buttrey, and Commissioner Mulvey.

**Vernon A. Williams,**

Secretary.

[FR Doc. E7–12163 Filed 6–22–07; 8:45 am]

**BILLING CODE 4915–01–P**

**DEPARTMENT OF THE TREASURY**

**Office of Thrift Supervision**

**Submission for OMB Review; Comment Request—Interagency Guidance on Asset Securitization Activities**

**AGENCY:** Office of Thrift Supervision (OTS), Treasury.

**ACTION:** Notice and request for comment.

**SUMMARY:** The proposed information collection requirement described below has been submitted to the Office of Management and Budget (OMB) for review and approval, as required by the Paperwork Reduction Act of 1995. OTS is soliciting public comments on the proposal.

**DATES:** Submit written comments on or before July 25, 2007.

**ADDRESSES:** Send comments, referring to the collection by title of the proposal or by OMB approval number, to OMB and OTS at these addresses: Office of Information and Regulatory Affairs, Attention: Desk Officer for OTS, U.S. Office of Management and Budget, 725–17th Street, NW., Room 10235, Washington, DC 20503, or by fax to (202) 395–6974; and Information Collection Comments, Chief Counsel’s Office, Office of Thrift Supervision, 1700 G Street, NW., Washington, DC