

U.S. DEPARTMENT OF TRANSPORTATION
NATIONAL HIGHWAY TRAFFIC SAFETY ADMINISTRATION

LABORATORY TEST PROCEDURE

FOR

FMVSS No. 206

Door Locks and Door Retention Components

Sliding Side Door Transverse Load Test



U. S. DEPARTMENT OF TRANSPORTATION
National Highway Traffic Safety Administration
Enforcement

Office of Vehicle Safety Compliance
Mail Code: NVS-220, W43-481
1200 New Jersey Avenue, SE
Washington, DC 20590

**OVSC TEST PROCEDURE TP-206S-01
TABLE OF CONTENTS**

	PAGE
1. PURPOSE AND APPLICATION	1
2. GENERAL REQUIREMENTS	3
3. SECURITY	5
4. GOOD HOUSEKEEPING	5
5. TEST SCHEDULING AND MONITORING.....	5
6. TEST DATA DISPOSITION	5
7. GOVERNMENT FURNISHED PROPERTY (GFP)	8
8. CALIBRATION OF TEST INSTRUMENTS	10
9. PHOTOGRAPHIC DOCUMENTATION	12
10. DEFINITIONS	13
11. PRETEST REQUIREMENTS.....	15
12. COMPLIANCE TEST EXECUTION	17
13. POST TEST REQUIREMENTS	25
14. REPORTS	26
14.1. MONTHLY STATUS REPORTS	26
14.2. APPARENT TEST FAILURE	26
14.3. FINAL TEST REPORTS.....	26
14.3.1. COPIES	26
14.3.2. REQUIREMENTS	27
14.3.3. FIRST THREE PAGES	27
14.3.4. TABLE OF CONTENTS.....	33
15. REPORT SECTIONS and DATA SHEETS	34
16. FORMS	42

**REVISION CONTROL LOG
FOR OVSC LABORATORY
TEST PROCEDURES**

TP-206S

TEST PROCEDURE		FMVSS 206		DESCRIPTION
REV. No.	DATE	AMENDMENT	EFFECTIVE DATE	
00	2/6/07	72FR5385	September 1, 2009	This procedure deals specifically with the sliding door transverse load test requirements of FMVSS No. 206.
01	2/19/10	75FR7370 74FR37176	February 19, 2010 September 1, 2009 (compliance date September 1, 2010)	Minor revisions, update standardized format, and update of applicability, sliding side door test procedures, and compliance date for sliding side door system requirements per amendment.
02	10/9/12	N/A	October 9, 2012	Update testing / vehicle securement procedure.
03				
04				
05				
06				
07				
08				
09				
10				
11				

1. PURPOSE AND APPLICATION

This document is provided by the National Highway Traffic Safety Administration (NHTSA), Office of Vehicle Safety Compliance (OVSC) for the purpose of presenting procedures for uniform testing and providing suggestions for the use of specific equipment for contracted testing laboratories. It contains requirements based on the test procedures specified in the Federal Motor Vehicle Safety Standard(s) (FMVSS) and any applicable safety Regulations. The OVSC test procedures include requirements that are general in scope to provide flexibility for contracted laboratories to perform compliance testing and are not intended to limit or restrain a contractor from developing or utilizing any testing techniques or equipment which will assist in procuring the required compliance test data. These test procedures do not constitute an endorsement or recommendation for use of any particular product or testing method.

Prior to conducting compliance testing, contracted laboratories are required to submit a detailed test procedure to the Contracting Officer's Technical Representative (COTR) to demonstrate concurrence with the OVSC laboratory test procedure and the applicable FMVSS. If any contractor views any part of an OVSC laboratory test procedure to be in conflict with a FMVSS or observes deficiencies in a laboratory test procedure, the contractor is required to advise the COTR and resolve the discrepancy prior to the start of compliance testing or as soon as practicable. The contractor's test procedure must include a step-by-step description of the methodology and detailed check-off sheets. Detailed check-off sheets shall also be provided for the testing instrumentation including a complete listing of the test equipment with make and model numbers. The list of test equipment shall include instrument accuracy and calibration dates. All equipment shall be calibrated in accordance with the manufacturer's instructions. There shall be no contradictions between the laboratory test procedure and the contractor's in-house test procedure. Written approval of the in-house test procedures shall be obtained from the COTR before initiating the compliance test program.

NOTE: The OVSC Laboratory Test Procedures, prepared for the limited purpose of use by independent laboratories under contract to conduct compliance tests for the OVSC, are not rules, regulations or NHTSA interpretations regarding the meaning of a FMVSS. The laboratory test procedures are not intended to limit the requirements of the applicable FMVSS(s). In some cases, the OVSC laboratory test procedures do not include all of the various FMVSS minimum performance requirements. In addition, the laboratory test procedures may specify test conditions that are less severe than the minimum requirements of the standard. The laboratory test procedures may be modified by the OVSC at any time without notice, and the COTR may direct or authorize contractors to deviate from these procedures, as long as the tests are performed in a manner consistent with the standard itself and within the scope of the contract. Laboratory test procedures may not be relied upon to create any right or benefit in any person. Therefore, compliance of a vehicle or item of

1. PURPOSE AND APPLICATION.....Continued

motor vehicle equipment is not necessarily guaranteed if the manufacturer limits its certification tests to those described in the OVSC laboratory test procedures.

2. GENERAL REQUIREMENTS

Federal Motor Vehicle Safety Standard (FMVSS) No. 206 establishes minimum performance requirements for motor vehicle door locks and door retention components. The purpose of Standard 206 is to minimize the likelihood of occupants being thrown from a vehicle as a result of impact. The standard applies to all side and back doors on passenger cars, multipurpose passenger vehicles, and trucks, and buses with a gross vehicle weight rating (GVWR) of 4,536 kg or less, that lead directly into a compartment that contains one or more seating accommodations and the associated door components. The standard does not apply to folding doors, roll-up doors, detachable doors, bus doors used only for emergency egress purposes and labeled accordingly and on bus doors to accommodate a permanently attached wheelchair lift system that when the device is in the retracted position, the lift platform retracts to a vertical orientation parallel to and in close proximity with the interior surface of the lift door and in that position, the platform completely covers the doorway opening, has fixed attachments to the vehicle and provides a barricade to the doorway. The bus wheelchair lift door must be linked to an alarm system consisting of either a flashing visible signal located in the driver's compartment or an alarm audible to the driver that is activated when the door is not fully closed and the vehicle ignition is activated.

The TP-206S-01 procedure specifically provides requirements for compliance testing of motor vehicle sliding side doors to the transverse load test requirements of FMVSS No. 206. Section S4.2.2 of FMVSS No. 206 requires that sliding side doors shall not separate (i.e. a separation which permits a sphere with a diameter of 100 mm to pass unobstructed between the exterior of the vehicle to the interior of the vehicle) when a total transverse load of 18,000 N is applied to the vehicle door. The requirements of S4.2.2 are applicable for vehicles manufactured after September 1, 2010. Each sliding side door transverse load test is conducted on a production vehicle with the sliding door and its retention components.

Section S4.2.1 of FMVSS No. 206 requires that each sliding side door system be equipped with either: (a) at least one primary door latch system, or (b) a door latch system with a fully latched position and a door closure warning system. The door closure warning system shall be located where it can be clearly seen by the driver.

METRIC SYSTEM OF MEASUREMENT

Section 5164 of the Omnibus Trade and Competitiveness Act (Pub. L. 100-418) establishes that the metric system of measurement is the preferred system of weights and measures for trade and commerce in the United States. Executive order 12770 directs Federal agencies to comply with the Act by converting regulatory standards to the metric system after September 30, 1992. In a final rule published on March 15, 1990 (60 FR 13639), NHTSA completed the first phase of metrication, converting English measurements in several regulatory standards to the metric system. Since then, metrication has been applied to other regulatory standards (63 FR 28912).

Accordingly, the OVSC laboratory test procedures include revisions to comply with governmental directives in using the metric system. Regulatory standards converted

2. GENERAL REQUIREMENTS.....Continued

to metric units are required to use metric measurements in the test procedures, whereas standards using English units are allowed to use English measurements or to use English measurements in combination with metric equivalents in parentheses.

All final compliance test reports are required to include metric measurements for standards using metrication.

NOTE: The methodology for rounding measurement in the test reports shall be made in accordance with ASTM E29-06b, "Standard Practice for Using Significant Digits in Test Data to Determine Conformance with Specifications."

3. SECURITY

The contractor shall provide appropriate security measures to protect the OVSC test vehicles and Government Furnished Property (GFP) from unauthorized personnel during the entire compliance testing program. The contractor is financially responsible for any acts of theft and/or vandalism which occur during the storage of test vehicles and GFP. Any security problems which arise shall be reported by telephone to the Industrial Property Manager (IPM), Office of Acquisition Management, within two working days after the incident. A letter containing specific details of the security problem shall be sent to the IPM (with copy to the COTR) within 48 hours.

The contractor shall protect and segregate the data that evolves from compliance testing before and after each vehicle test. No information concerning the vehicle safety compliance testing program shall be released to anyone except the COTR, unless specifically authorized by the COTR or the COTR's Division Chief.

NOTE: No individuals, other than contractor personnel directly involved in the compliance testing program or OVSC personnel, shall be allowed to witness any vehicle or equipment item compliance test or test dummy calibration unless specifically authorized by the COTR.

4. GOOD HOUSEKEEPING

Contractors shall maintain the entire vehicle compliance testing area, fixtures and instrumentation in a neat, clean and painted condition with test instruments arranged in an orderly manner consistent with good test laboratory housekeeping practices.

5. TEST SCHEDULING AND MONITORING

The contractor shall submit a test schedule to the COTR prior to conducting the first compliance test. Tests shall be completed at intervals as required in the contract. If not specified, the first test shall be conducted within 6 weeks after receiving the first delivered unit. Subsequent tests shall be completed in no longer that 1 week intervals unless otherwise specified by the COTR.

Scheduling of tests shall be adjusted to permit vehicles (or equipment, whichever applies) to be tested to other FMVSSs as may be required by the OVSC. All compliance testing shall be coordinated with the COTR in order to allow monitoring by the COTR and/or other OVSC personnel if desired. The contractor shall submit a monthly test status report and a vehicle status report (if applicable) to the COTR. The vehicle status report shall be submitted until all vehicles are disposed of. The status report forms are provided in the forms section.

6. TEST DATA DISPOSITION

The Contractor shall make all preliminary compliance test data available to the COTR on location within four hours after the test. Final test data, including digital printouts

6. TEST DATA DISPOSITION.....Continued

and computer generated plots (if applicable), shall be available to the COTR in accordance with the contract schedule or if not specified, within two working days. Additionally, the Contractor shall analyze the preliminary test results as directed by the COTR.

The test data shall be retained by the contractor for a minimum of 3 years after conclusion of each delivery order, purchase order, etc.

The contractor shall protect and segregate the data that evolves from compliance testing before and after each test.

TEST DATA LOSS

A. INVALID TEST DESCRIPTION

An invalid compliance test is one, which does not conform precisely to all requirements/specifications of the OVSC Laboratory Test Procedure and Statement of Work applicable to the test.

B. INVALID TEST NOTIFICATION

The Contractor shall notify NHTSA of any test not meeting all requirements/specifications of the OVSC Laboratory Test Procedure and Statement of Work applicable to the test, by telephone, within 24 hours of the test and send written notice to the COTR within 48 hours of the test completion.

C. RETEST NOTIFICATION

The Contracting Officer of NHTSA is the only NHTSA official authorized to notify the Contractor that a retest is required. The retest shall be completed within 2 weeks after receipt of notification by the Contracting Officer that a retest is required.

D. WAIVER OF RETEST

NHTSA, in its sole discretion, reserves the right to waive the retest requirement. This provision shall not constitute a basis for dispute over the NHTSA's waiving or not waiving any requirement.

E. TEST VEHICLE

NHTSA shall furnish only one vehicle for each test ordered. The Contractor shall furnish the test vehicle required for the retest. The retest vehicle shall be equipped as the original vehicle. The original vehicle used in the invalid test shall remain the property of NHTSA, and the retest vehicle shall remain the property of the Contractor. The Contractor shall retain the retest vehicle for a period not exceeding 180 days if it

6. TEST DATA DISPOSITION.....Continued

fails the test. If the retest vehicle passes the test, the Contractor may dispose of it upon notification from the COTR that the test report has been accepted.

F. TEST REPORT

No test report is required for any test that is determined to be invalid unless NHTSA specifically decides, in writing, to require the Contractor to submit such report. The test data from the invalid test must be safeguarded until the data from the retest has been accepted by the COTR. The report and other required deliverables for the retest vehicle are required to be submitted to the COTR within 3 weeks after completion of the retest.

G. DEFAULT

The Contractor is subject to the default and subsequent reprourement costs for non-delivery of valid or conforming tests (pursuant to the Termination For Default clause in the contract).

H. NHTSA'S RIGHTS

None of the requirements herein stated shall diminish or modify the rights of NHTSA to determine that any test submitted by the Contractor does not conform precisely to all requirements/specifications of the OVSC Laboratory Test Procedure and Statement of Work applicable to the test.

7. GOVERNMENT FURNISHED PROPERTY (GFP)

GFP consists of test vehicles. The GFP is authorized by contractual agreement. The contractor is responsible for the following.

A. ACCEPTANCE OF TEST VEHICLES

The contractor has the responsibility of accepting each GFP test vehicle whether delivered by a new vehicle dealership or another vehicle transporter. In both instances, the Contractor acts on behalf of the OVSC when signing an acceptance of the GFP test vehicle delivery order. When a GFP vehicle is delivered, the contractor must verify:

1. All options listed on the "window sticker" are present on the test vehicle.
2. Tires and wheel rims are new and the same as listed.
3. There are no dents or other interior or exterior flaws in the vehicle body.
4. The vehicle has been properly prepared and is in running condition.
5. The glove box contains an owner's manual, warranty document, consumer information, and extra set of keys.
6. Proper fuel filler cap is supplied on the test vehicle.
7. Spare tire, jack, lug wrench and tool kit (if applicable) is located in the vehicle cargo area.
8. The VIN (vehicle identification number) on the vehicle condition report matches the VIN on the vehicle.
9. The vehicle is equipped as specified by the COTR.

A Vehicle Condition form will be supplied to the Contractor by the COTR when the test vehicle is transferred from a new vehicle dealership or between test contracts. The upper half of the form is used to describe the vehicle as initially accepted. The lower half of the Vehicle Condition form provides space for a detailed description of the post-test condition. The contractor must complete a Vehicle Condition form for each vehicle and deliver it to the COTR with the Final Test Report or the report will NOT be accepted for payment.

If the test vehicle is delivered by a government contracted transporter, the contractor should check for damage which may have occurred during transit. GFP vehicle(s) shall not be driven by the contractor on public roadways unless authorized by the COTR.

7. GOVERNMENT FURNISHED PROPERTY (GFP).....Continued**B. NOTIFICATION OF COTR**

The COTR must be notified within 24 hours after a vehicle has been delivered. In addition, if any discrepancy or damage is found at the time of delivery, a copy of the Vehicle Condition form shall be sent to the COTR immediately.

8. CALIBRATION OF TEST INSTRUMENTS

Before the Contractor initiates the vehicle safety compliance test program, a test instrumentation calibration system must be implemented and maintained in accordance with established calibration practices. The calibration system shall include the following as a minimum:

- A. Standards for calibrating the measuring and test equipment shall be stored and used under appropriate environmental conditions to assure their accuracy and stability.
- B. All measuring instruments and standards shall be calibrated by the Contractor, or a commercial facility, against a higher order standard at periodic intervals not exceeding 12 months for instruments and 12 months for the calibration standards except for static types of measuring devices such as rulers, weights, etc., which shall be calibrated at periodic intervals not to exceed two years. Records, showing the calibration traceability to the National Institute of Standards and Technology (NIST), shall be maintained for all measuring and test equipment.

Accelerometers shall be calibrated every twelve months or after a test failure or after any indication from calibration checks that there may be a problem with the accelerometer whichever occurs sooner.

- C. All measuring and test equipment and measuring standards shall be labeled with the following information:
 - 1. Date of calibration
 - 2. Date of next scheduled calibration
 - 3. Name of the technician who calibrated the equipment
- D. A written calibration procedure shall be provided by the Contractor, which includes as a minimum the following information for all measurement and test equipment:
 - 1. Type of equipment, manufacturer, model number, etc.
 - 2. Measurement range
 - 3. Accuracy
 - 4. Calibration interval
 - 5. Type of standard used to calibrate the equipment (calibration traceability of the standard must be evident).
 - 6. The actual procedures and forms used to perform the calibrations.

8. CALIBRATION OF TEST INSTRUMENTS.....Continued

- E. Records of calibration for all test instrumentation shall be kept by the Contractor in a manner that assures the maintenance of established calibration schedules.
- F. All such records shall be readily available for inspection when requested by the COTR. The calibration system shall need the acceptance of the COTR before vehicle safety compliance testing commences.
- G. Test equipment shall receive a system functional check out using a known test input immediately before and after the test. This check shall be recorded by the test technician(s) and submitted with the final report.
- H. The Contractor may be directed by NHTSA to evaluate its data acquisition system.

Further guidance is provided in the International Standard ISO 10012-1, "Quality Assurance Requirements for Measuring Equipment" and American National Standard ANSI/NCSL Z540-1, "Calibration Laboratories and Measuring and Test Equipment General Requirements."

NOTE: In the event of a failure to meet the standard's minimum performance requirements additional calibration checks of some critically sensitive test equipment and instrumentation may be required for verification of accuracy. The necessity for the calibration will be at the COTR's discretion and shall be performed without additional cost.

9. PHOTOGRAPHIC DOCUMENTATION

Digital Photographs

The contractor shall take digital photographs of the test execution procedures. Photographs shall be taken in color and contain clear images. A tag, label or placard identifying the test item, NHTSA number (if applicable) and date shall appear in each photograph and must be legible. Each photograph shall be labeled as to the subject matter. The required resolution for digital photographs is a minimum of 1,600 x 1,200 pixels. Digital photographs are required to be created in color and in a JPG format. Glare or light from any illuminated or reflective surface shall be minimized while taking photographs.

The test reports shall include enough photographs to describe the testing in detail and shall be organized in a logical succession of consecutive pictures. The digital photographs shall be included in the test report as 203 mm x 254 mm or 215.9 mm x 279 mm (8 x 10 or 8½ x 11 inch) pictures. All photographs are required to be included in the test report in the event of a test failure. Any failure must be photographed at various angles to assure complete coverage. Upon request, the photographs shall be sent to the COTR on a CD or DVD and saved in a “read only” format to ensure that the digital photographs are the exact pictures taken during testing and have not been altered from the original condition.

9.1 Photographic Views

Each final test report shall include digital photographs of the test setup used for each sliding door transverse load test, including pre-test and post-test photographs of the vehicle being tested. The photographs shall include a placard in view that identifies the test laboratory, the test date, test vehicle year, make and model, the words “FMVSS no. 206 Sliding Door Transverse Load Test”, and the words “Pre-Test” or “Post-Test” as appropriate.

If a test failure occurs, additional digital photographs shall be taken to document each test failure including regions of the door which exceed the 100 mm gap requirement, and areas of structural failure of the sliding door system.

9.2 Video Coverage

Each sliding door transverse load test shall be recorded with digital video cameras fully documenting the entire test. The camera views shall include the inside and outside view of the test vehicle on the side showing the subject sliding door being tested. The video coverage shall include a time counter to record the time (accurate to at least one second) throughout the test, including an audible and/or visual signal to signify the start of the loading test, when the door is fully loaded, and the end of the test as applicable. The video coverage shall include a placard in view just before the start of each test that identifies the test laboratory, the test date, test vehicle year, make and model, and the words “FMVSS no. 206 Sliding Door Transverse Load Test”. Ensure, using a separate digital video camera if necessary, that the video coverage complies with the requirements specified in section 12.1.3 (f).

10. DEFINITIONS

Auxiliary Door Latch is a latch equipped with a fully latched position, with or without a secondary latched position, and fitted to a door or door system equipped with a primary door latch system.

Auxiliary Door Latch System consists of door latches and strikers other than those associated with the primary latch system.

Back Door is a door or door system on the back end of a motor vehicle through which passengers can enter or depart the vehicle or cargo can be loaded or unloaded. It does not include:

A trunk lid; or

A door or window composed entirely of glazing material and whose latches and/or hinge systems are attached directly to the glazing material.

Door Closure Warning System is a system that will activate a visual signal when a door latch system is not in its fully latched position and the vehicle ignition is activated.

Door Latch System consists of latches and strikers installed on a door system.

Door System is the door, latch, striker, hinges, sliding track combinations and other door retention components on a door and its surrounding doorframe. The door system of a double door includes both doors.

Double Door is a system of two doors where the front door or wing door opens first and connects to the rear door or bolted door, which opens second.

Folding Door is a movable barrier, which will close off an entranceway to a bus, multipurpose passenger vehicle or truck, consisting of two or more hinge panels that swing, slide, or rotate; does not have a striker and latch assembly

Fully Latched Position is the coupling condition of the latch that retains the door in a completely closed position.

Latch is a device employed to maintain the door in a closed position relative to the vehicle body with provisions for deliberate release (or operation).

Primary Door Latch is a latch equipped with both a fully latched position and a secondary latched position and is designated as a "primary door latch" by the manufacturer (by the time it certifies the vehicle and may not thereafter alter the designation).

Primary Door Latch System consists of a primary door latch(s) and a striker(s).

Secondary Latched Position refers to the coupling condition of the latch that retains the door in a partially closed position.

Striker is a device with which the latch engages to maintain the door in the fully latched or secondary latched position.

10. DEFINITIONS....Continued

Trunk Lid is a movable body panel that provides access from outside the vehicle to a space wholly partitioned from the occupant compartment by a permanently attached partition or fixed or fold-down seat back.

11. PRETEST REQUIREMENTS

11.1 IN-HOUSE TEST PROCEDURE

Every contractor is required to submit a detailed in-house test procedure to the COTR before initiating the compliance test program. The procedure must include a step-by-step description of the methodology to be used. The contractor's test procedure shall contain a detailed check-off sheet and a complete listing of test equipment with makes and model numbers. The list of test equipment shall include instrument accuracy and calibration dates. There shall be no contradictions between the OVSC Laboratory Test Procedure and the contractor's in-house procedure without COTR agreement. The procedures shall cover all aspects of testing from vehicle receipt to submission of the final report. Written approval of the in-house test procedure and all subsequent revisions shall be obtained from the COTR. The in-house procedure shall include the following:

- A. A step-by-step description of the methodology and test procedure to be used.
- B. A written Quality Control (QC) procedure which shall include calibrations, the data review process, report review, and the people assigned to perform QC per task.
- C. A complete listing of test equipment which shall include instrument accuracy and calibration dates.
- D. Detailed check-off lists to be used during the test and during data review. These lists shall include all test procedure requirements and FMVSS requirements pertaining to the safety standard for which testing is being performed. Each separate check-off sheet shall identify the lab, test date, vehicle and test technicians. These check sheets shall be used to document that all requirements and procedures have been complied with. These sheets shall be submitted with the test report.

11.2 INSTRUMENTATION AND DATA ACQUISITION

11.2.1 Vehicle Sliding Side Door Transverse Load Test

Each vehicle transverse load test shall use two load cells (one for each door edge) and a data acquisition system capable of providing continuous recording (or discrete measurements recorded at an adequately high sampling rate) and shall be capable of providing data accurate to within ± 1 percent up to the required test load of 9,000 N on each door edge (18,000 N total load on door).

Each vehicle transverse load test shall also include instrumentation for the displacement measurement of each force application device used to load each door edge. Each displacement measurement device (such as a linear potentiometer) and displacement data acquisition system shall be capable of providing continuous recording (or discrete measurements recorded at an adequately high sampling rate) and shall be capable of providing data accurate to within ± 0.5 mm up to the maximum ram displacement of 300 mm.

11. PRETEST REQUIREMENTS....Continued

11.3 TEST CONDITIONS

Unless otherwise specified, all tests and measurements shall be conducted under the following environmental conditions:

A. Temperature: 75°F ± 15°F (21°C ± 3°C)

11.4 TEST PERSONNEL PERFORMANCE

Personnel supervising and/or performing the compliance test program shall be thoroughly familiar with the requirements, test conditions, equipment for the test to be conducted, and safety requirements.

11.5 TEST DATA

Data will be submitted on the Test Data Sheet forms specified for use in the final test report. Data will be typed before the sheets are submitted. One set of Inspection and Test Data sheets shall be completed for each vehicle. The following are requirements for each vehicle inspection entry:

- (a) Vehicle Manufacturer
- (b) Vehicle Make/Model
- (c) Date of Manufacture
- (d) VIN
- (e) Vehicle Certified As (Pass. Car/MPV/Truck/Bus)
- (f) Total GVWR
- (g) Number of latches on each edge of driver side sliding side door
- (h) Number of latches on each edge of passenger side sliding side door
- (i) Verify each sliding side door contains at least one primary door latch system, or a door system with a fully latched position and a door closure warning system visible by the driver

12. COMPLIANCE TEST EXECUTION

12.1 VEHICLE SLIDING SIDE DOOR TRANSVERSE LOAD TEST

12.1.1 Test Equipment

- (a) The test is conducted using two force application devices (e.g. hydraulic rams) capable of applying the outward transverse forces on the vehicle sliding door up to 8,900 N (± 100 N) each, and for a minimum displacement of 300 mm.
- (b) Rigid fixturing shall be used for each force application device to provide a support structure that maintains the transverse alignment throughout the load test while limiting motion in the vehicle longitudinal and vertical axes. The support structure shall be designed with a height adjustment (2-feet recommended) for positioning the height of the force application device loading plate as required for each test vehicle per the requirements specified in section 12.1.2. A typical test fixture configuration is illustrated in Figures 1 and 2, which show the side and top views, respectively, of a hydraulic ram (3.5-inch diameter bore with 2-inch diameter shaft and a 24-inch stroke) and rear-mounted load cell assembled in a rectangular framework. A forward-mounted load cell can be utilized when configured to minimize off-axis loading. Alternate test fixture support structure configurations can be utilized such that they provide sufficient rigidity for each force application device.
- (c) A steel rectangular loading plate (force application plate) shall be mounted to the front of each force application device to distribute and apply the load to the door. Figure 3 illustrates the required loading configuration relative to the vehicle door. The loading plate configuration shall be as specified in section 12.1.2 for each test vehicle configuration as applicable. The loading plate edges shall be rounded to a radius of $6 \text{ mm} \pm 1 \text{ mm}$. The loading plate / force application device interface joint shall be designed such that the loading plate is rigidly fixed perpendicular to the force application device and moves in the transverse direction. For alignment purposes with the door edge contour, each plate is attached to the force application device in a manner that allows for rotation about the vehicle's y-axis (see Figure 4). In this manner, the face of each plate remains parallel to the vertical plane which passes through the vehicle's longitudinal centerline. The rotational allowance aids in positioning the plates near the respective door edge as specified in section 12.1.2.
- (d) For each force application device, a displacement transducer (e.g. string potentiometer) for measuring the force application device displacement shall be positioned to measure the linear transverse displacement of the loading plate.
- (e) A 100 mm (+5, -0 mm) diameter sphere mounted onto a long flexible shaft (as deemed appropriate by the contractor to ensure technician safety as highlighted in section 12.1.2 (e)) shall be used for measuring the sliding door gap as specified in section 12.1.3.

12. COMPLIANCE TEST EXECUTION...Continued

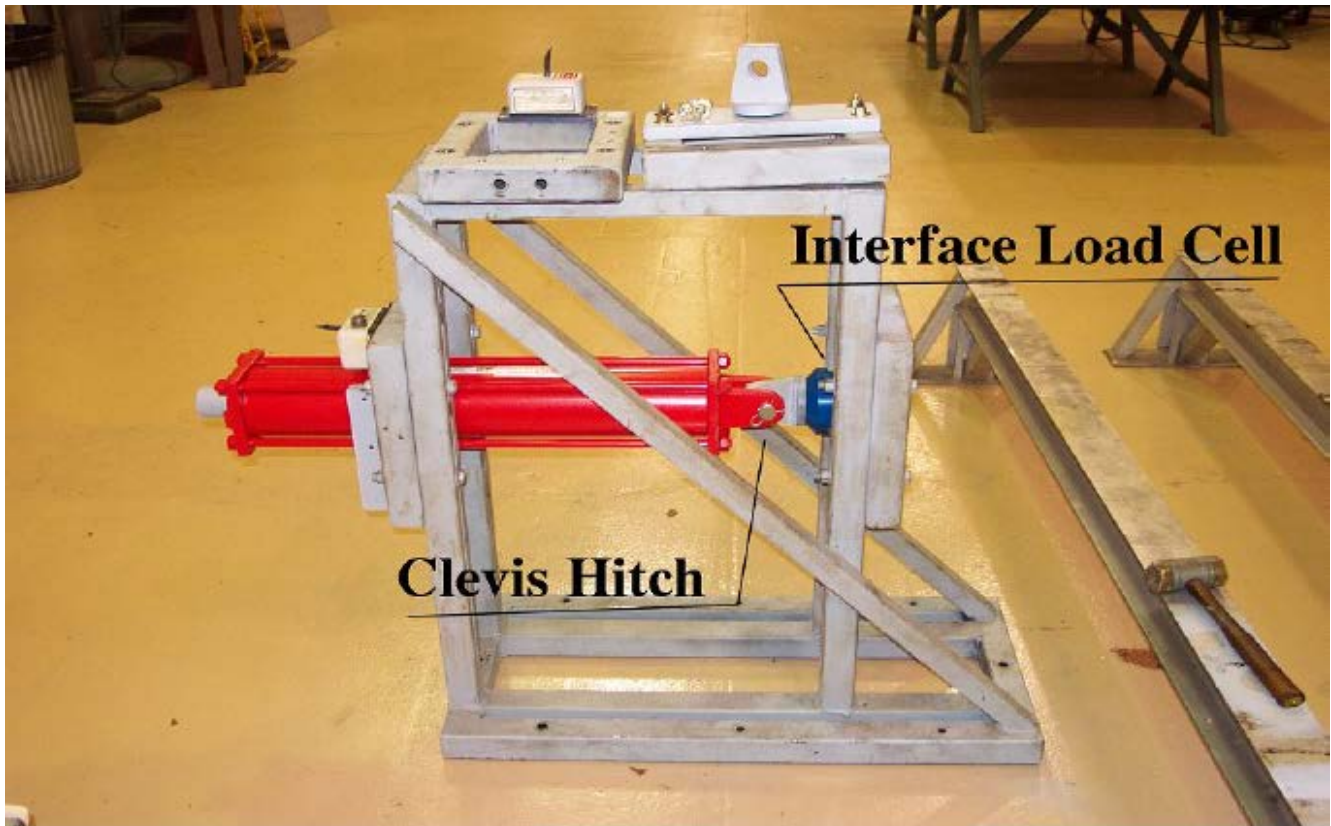

Figure 1 - Typical Test Fixture Side view



Figure 2 - Typical Test Fixture Top View

12. COMPLIANCE TEST EXECUTION...Continued

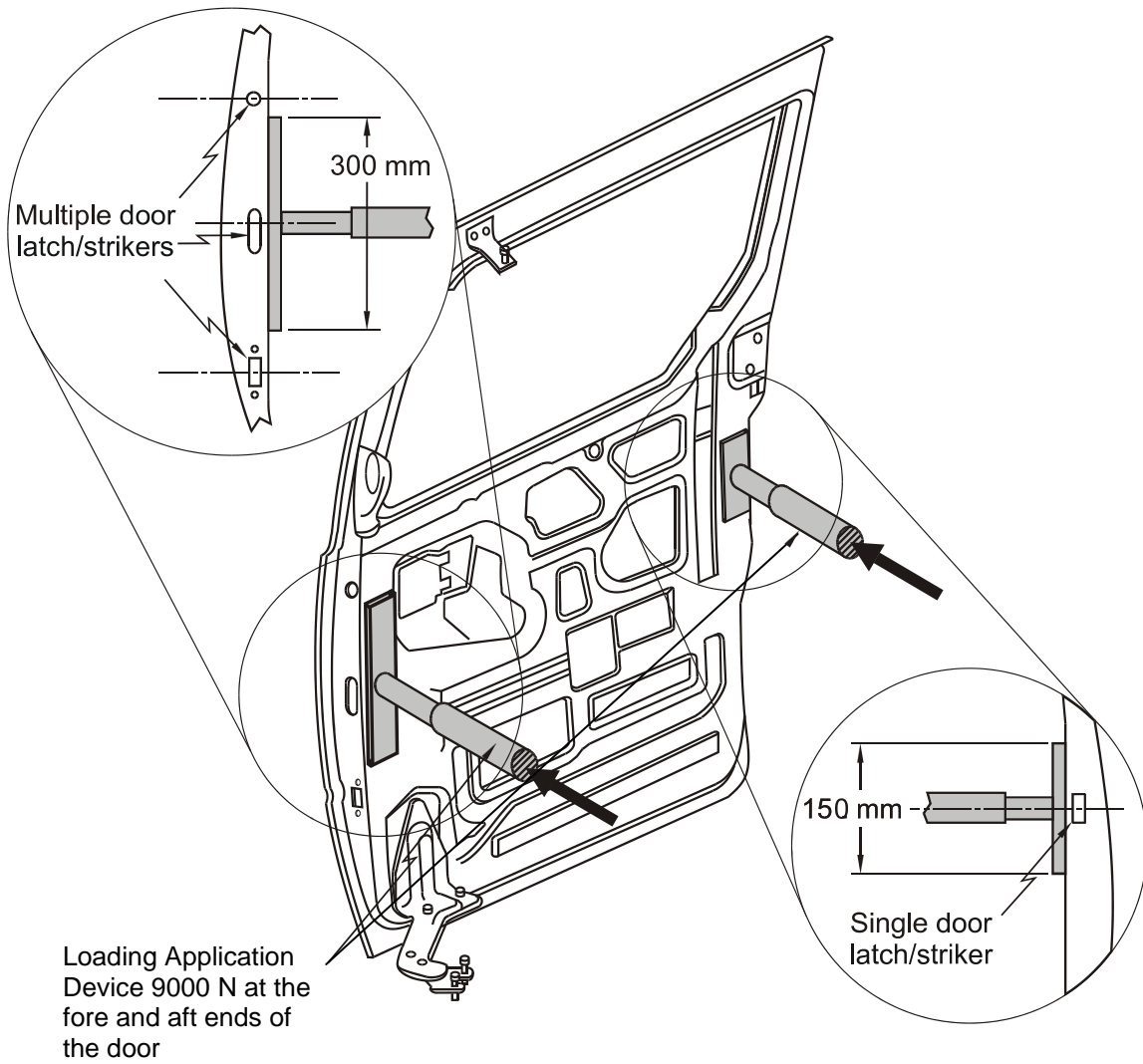

FIGURE 3 – Sliding Door Vehicle Test Procedure
(Note: Sliding door is shown separated from the vehicle)

12. COMPLIANCE TEST EXECUTION...Continued

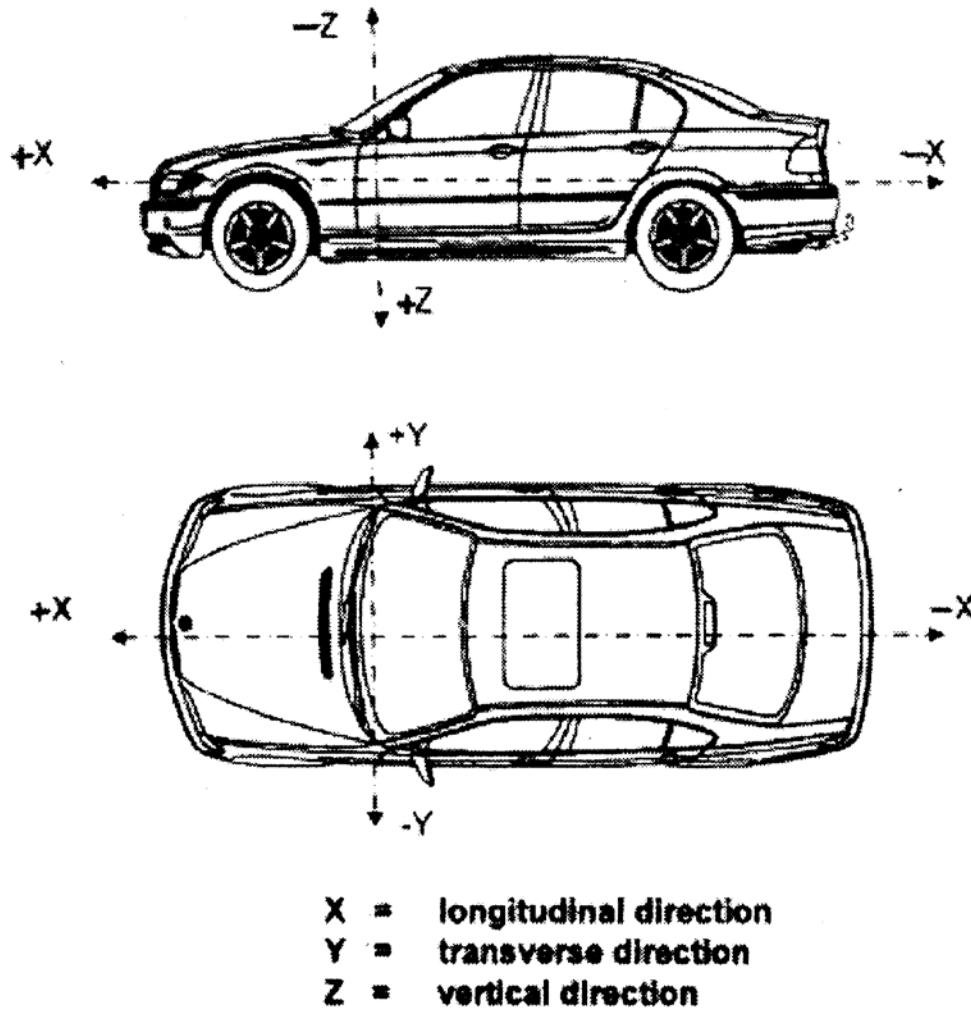

FIGURE 4 – Vehicle Coordinate Reference System

12. COMPLIANCE TEST EXECUTION...Continued

12.1.2 Test Setup

- (a) Secure the underside of the vehicle onto a level rigid mounting surface similar to the procedure specified in TP-214S-05 (Side Impact Protection – Static). This involves a simple tie-down of the vehicle underbody using wire rope, turnbuckles, strap plates, etc. As practicable, place the tie-downs at or forward of the front wheel lateral centerline and at or rearward of the rear wheel lateral centerline.
- (b) Remove all interior trim and decorative components from the sliding door assembly.
- (c) Remove seats and any interior components that may interfere with the mounting and operation of the test equipment and all pillar trim and any non-structural components that overlap the door and cause improper placement of the force application plates.
- (d) Mount the force application devices and associated support structure assemblies to the floor of the test vehicle such that each device is within $\pm 1.0^\circ$ of horizontal. The force application devices shall be aligned parallel to each other in the vehicle transverse axis, with each applied force perpendicular ($\pm 1.0^\circ$) to the vertical longitudinal plane that passes through the vehicle's longitudinal centerline, and vertically centered per the requirements in paragraphs (g), (h), and (i) below as applicable. To distribute the loading on the floor of the test vehicle, and to provide a smooth-level mounting surface for each force application device and support structure assembly, each assembly shall be rigidly fixed onto aluminum or steel plates and bolted onto the floor of the test vehicle. To further assist in distributing the loading on the floor of the test vehicle, metal plates shall be used as washers on the underside of the floor of the test vehicle (typically requires removal of gas tank and portions of exhaust system). For the typical test fixture shown in Figures 1 and 2, a typical aluminum plate would be approximately 2 feet by 4 feet and $\frac{1}{2}$ -inch in thickness; a typical metal washer would be approximately 2-inch by 2-inch and $\frac{1}{4}$ -inch in thickness; and a typical mounting bolt would be a $\frac{5}{8}$ -inch grade 8 bolt.
- (e) Determine the forward and aft edge of the sliding door, or its adjoining vehicle structure, that contains a latch/ striker. Mark each location near the inside edge of the door as follows (± 3.0 mm):
 - (1) For any tested door edge that contains one latch/striker, mark the vertical center of the door-mounted portion of the latch/striker.
 - (2) For any tested door edge that contains more than one latch/striker, mark the point vertically midway between the outermost edges of the latch/striker assemblies.
 - (3) For any tested door edge that does not contain at least one latch/striker, mark the point vertically midway along the length of the door edge (see Figure 5).

12. COMPLIANCE TEST EXECUTION...Continued

- (f) Close the sliding door, ensuring that all door retention components are fully engaged.
- (g) For any tested door edge that contains one latch/striker, the following set-up procedures are used:
 - (1) The force application plate shall be 150 mm in length, 50 mm in width, and at least 15 mm in thickness (all dimensions ± 0.5 mm).
 - (2) Place the force application device and force application plate against the door so that the applied force is perpendicular to the vertical longitudinal plane that passes through the vehicle's longitudinal centerline, and vertically centered on the door-mounted portion of the latch/striker.
 - (3) The force application plate shall be positioned such that the long edge of the plate is as close to the interior edge of the door as possible, but not such that the forward edge of the forward plate and the rear edge of the rear plate are more than 12.5 mm from the respective interior edges of the door. It is not necessary for the force application plate to be vertical.
- (h) For any tested door edge that contains more than one latch/striker, the following setup procedures are used:
 - (4) The force application plate shall be 300 mm in length, 50 mm in width, and at least 15 mm in thickness (all dimensions ± 0.5 mm).
 - (5) Place the force application device and force application plate against the door so that the applied force is perpendicular to the vertical longitudinal plane that passes through the vehicle's longitudinal centerline, and vertically centered on a point midway between the outermost edges of the latch/striker assemblies.
 - (6) The force application plate shall be positioned such that the long edge of the plate is as close to the interior edge of the door as possible, but not such that the forward edge of the forward plate and the rear edge of the rear plate are more than 12.5 mm from the respective interior edges of the door. It is not necessary for the force application plate to be vertical.
- (i) For any tested door edge that does not contain at least one latch/striker, the following set-up procedures are used:
 - (7) The force application plate shall be 300 mm in length, 50 mm in width, and at least 15 mm in thickness (all dimensions ± 0.5 mm).
 - (8) Place the force application device and force application plate against the door so that the applied force is perpendicular to the vertical longitudinal plane that passes through the vehicle's longitudinal centerline, and vertically centered on a point mid-way along the length of the door edge (i.e., midway along the surface length of the door edge, see Figure 5) ensuring that the loading device avoids contact with the window glazing.

12. COMPLIANCE TEST EXECUTION...Continued

- (9) The force application plate shall be positioned such that the long edge of the plate is as close to the interior edge of the door as possible, but not such that the forward edge of the forward plate and the rear edge of the rear plate are more than 12.5 mm from the respective interior edges of the door. It is not necessary for the force application plate to be vertical.

Illustration of door length determination for a particular sliding door edge that does not contain at least one latch/striker.

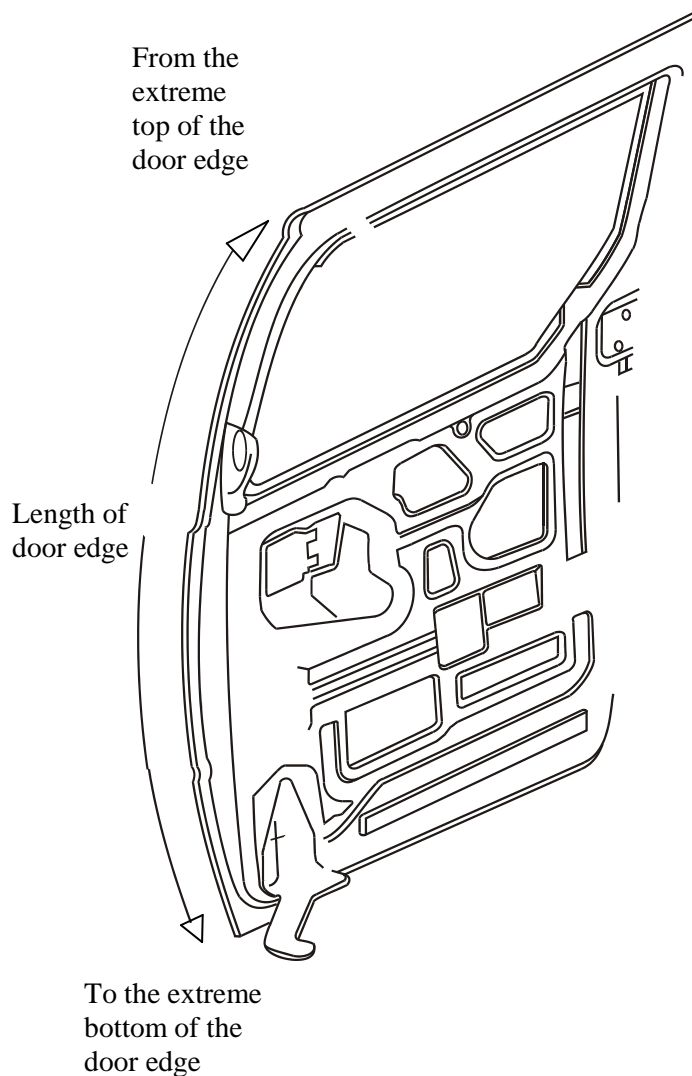

FIGURE 5. LENGTH DETERMINATION OF A PARTICULAR SLIDING DOOR EDGE

12. COMPLIANCE TEST EXECUTION....Continued

- (j) Ensure that the door is unlocked. No extra fixtures or components may be welded or affixed to the sliding door or any of its components.
- (k) Adjust each load application structure so that the force application plates are in contact with the interior of the sliding door.

12.1.3 Test Procedure

- (a) Apply a preload of 500 N (± 150 N) to each force application device. Zero the displacement measurement devices.
- (b) Increase the force on each force application device as linearly as practicable until a force of 8,900 N (± 100 N) is achieved on each force application device in not less than 90 seconds and not more than 120 seconds, or until either force application device reaches a total displacement of 300 mm.
- (c) If one of the force application devices reaches the target force of 8,900 N (± 100 N) prior to the other, maintain the 8,900 N (± 100 N) force with that force application device until the second force application device reaches a force of 8,900 N (± 100 N).
- (d) Once both force application devices have achieved the target 8,900 N (± 100 N) each, hold the resulting load.
- (e) While maintaining each force application device load as specified in section 12.1.3 (d) above, and within 30 seconds, verify that a 100 mm (+5, -0 mm) diameter sphere will not pass unobstructed between the exterior edge of the doorframe and the interior of the door at any location along the perimeter of the door. (See Figure 6).

Important Safety Note: The contractor shall take appropriate safety precautions, including use of appropriate safety gear, to ensure adequate personnel safety for the door gap assessment operation while the test vehicle is under load.

- (f) The door gap assessment operation per section 12.1.3 (e) above shall be video recorded clearly documenting any regions of failure (i.e., regions where the 100 mm diameter sphere was able to pass unobstructed between the exterior edge of the doorframe and the interior of the door at any location along the perimeter of the door).
- (g) Following completion of the test, retract the loads.

12. COMPLIANCE TEST EXECUTION...Continued

FIGURE 6. EVALUATION OF SLIDING DOOR GAP SEPARATION

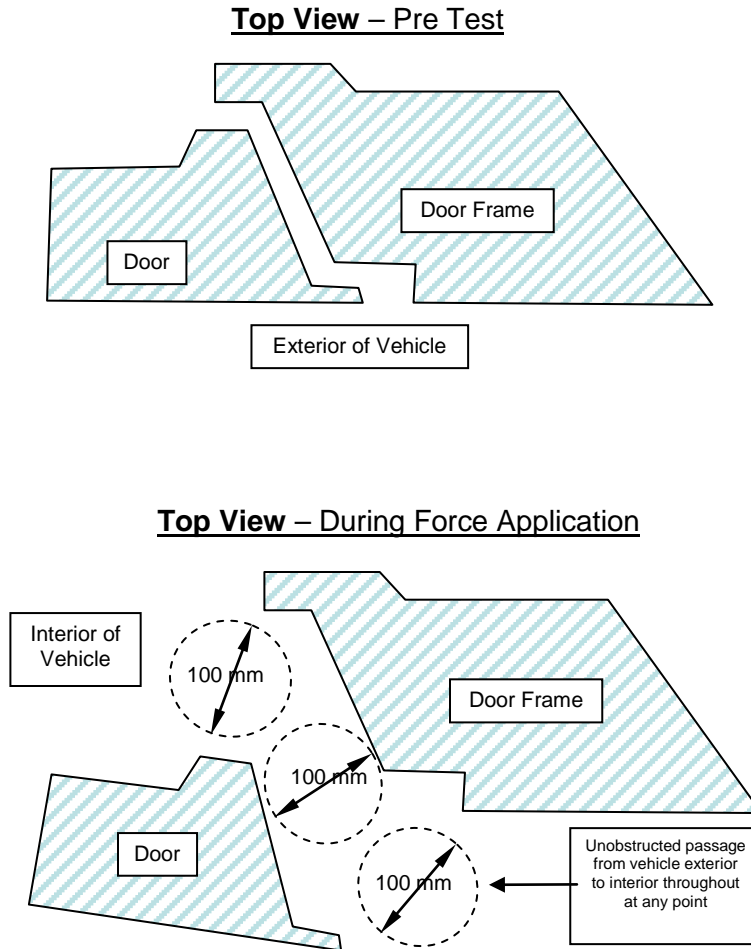

13. POST TEST REQUIREMENTS

The contractor shall re-verify all instrumentation and check data sheets and photographs. Make sure data is recorded in all data blocks on every compliance test data sheet.

14. REPORTS

14.1 MONTHLY STATUS REPORTS

The contractor shall submit a monthly Test Status Report and a Vehicle Status Report to the COTR. The Vehicle Status report shall be submitted until all vehicles are disposed of. Samples of the required reports are found in the report forms section.

14.2 APPARENT TEST FAILURE

Any indication of a test failure shall be communicated by telephone to the COTR within 24 hours with written notification mailed within 48 hours (Saturdays and Sundays excluded). A Notice of Test Failure (see report forms section) with a copy of the particular compliance test data sheet(s) and preliminary data plot(s) shall be included. In the event of a test failure, a post test calibration check of some critically sensitive test equipment and instrumentation may be required for verification of accuracy. The necessity for the calibration shall be at the COTR's discretion and shall be performed without additional costs to the OVSC.

14.3 FINAL TEST REPORTS

14.3.1 COPIES

Two hard copies of each Final Test Report and one electronic copy shall be submitted to the COTR for acceptance within two weeks of test completion. The Final Test Report format to be used by all contractors is specified in the following subsections, and sample Data Sheet formats are included in section 15. The electronic copy shall be submitted on Compact Disc Recordable (CDR) in Microsoft Soft (MS) Word format and Adobe Acrobat Portable Document Format (PDF), or the electronic copy may be emailed directly to the COTR.

Payment of contractor's invoices for completed compliance tests may be withheld until the Final Test Report is accepted by the COTR. Contractors are requested to NOT submit invoices before the COTR is provided copies of the Final Test Report.

Contractors are required to submit the first Final Test Report in typed draft form within two (2) weeks after the compliance test is conducted. The contractor and the COTR will then be able to discuss the details of both test conduct and report content early in the compliance test program.

Contractors are required to PROOF READ all Final Test Reports before submittal to the COTR. The OVSC will not act as a report quality control office for contractors. Reports containing a significant number of errors will be returned to the contractor for correction, and a "hold" will be placed on invoice payment for the particular test.

14. REPORTS....Continued

14.3.2 REQUIREMENTS

The Final Test Report and associated documentation (including photographs) are relied upon as the chronicle of the compliance test. The Final Test Report will be released to the public domain after review and acceptance by the COTR.

For these reasons, each final report must be a complete document capable of standing by itself. The contractor should use DETAILED descriptions of all compliance test events. Any events that are not directly associated with the standard but are of technical interest should also be included. The contractor should include as much DETAIL as possible in the report. Instructions for the preparation of the first three pages of the final test report are provided for standardization.

14.3.3 FIRST THREE PAGES

A. FRONT COVER

A heavy paperback cover (or transparency) shall be provided for the protection of the final report. The information required on the cover is as follows:

- (1) Final Report Number such as 206-ABC-20XX-00X, where –

206 is the FMVSS tested
 ABC are the initials for the laboratory
 20XX is the Fiscal Year of the test program
 00X is the Group Number

- (2) Final Report Title And Subtitle such as:

VEHICLE SAFETY COMPLIANCE TESTING
 FMVSS No. 206, Door Locks and Door Retention Components
 Sliding Side Door Transverse Load Test

World Motors Corporation
 20XX Safe Rider Van
 NHTSA No.:

- (3) Contractor's Name and Address such as

COMPLIANCE TESTING LABORATORIES, INC.
 4335 West Dearborn Street
 Detroit, Michigan 48090-1234

14. REPORTS....Continued

NOTE: DOT SYMBOL WILL BE PLACED BETWEEN ITEMS (3) AND (4)



- (4) Date of Final Report completion
- (5) The words "FINAL REPORT"
- (6) The sponsoring agency's name and address as follows

U. S. DEPARTMENT OF TRANSPORTATION
National Highway Traffic Safety Administration
Enforcement
Office of Vehicle Safety Compliance
Mail Code: NVS-220, W43-481
1200 New Jersey Avenue, SE
Washington, DC 20590

14. REPORTS....Continued

B. FIRST PAGE AFTER FRONT COVER

When a contract test laboratory is reporting, a disclaimer statement and an acceptance signature block for the COTR shall be provided as follows:

This publication is distributed by the National Highway Traffic Safety Administration in the interest of information exchange. Opinions, findings and conclusions expressed in this publication are those of the author(s) and not necessarily those of the Department of Transportation or the National Highway Traffic Safety Administration. The United States Government assumes no liability for its contents or use thereof.

If trade or manufacturers' names or products are mentioned, it is only because they are considered essential to the object of the publication and should not be construed as an endorsement.

Prepared By: _____

Approved By: _____

Approval Date: _____

FINAL REPORT ACCEPTANCE BY OVSC:

Accepted By: _____

Acceptance Date: _____

14. REPORTS....Continued**C. SECOND PAGE AFTER FRONT COVER**

A completed Technical Report Documentation Page (Form DOT F1700.7) shall be completed for those items that are applicable with the other spaces left blank. Sample data for the applicable block numbers of the title page follows.

Block 1 — REPORT NUMBER

206-ABC-20XX-00X

Block 2 — GOVERNMENT ACCESSION NUMBER

Leave blank

Block 3 — RECIPIENT'S CATALOG NUMBER

Leave blank

Block 4 — TITLE AND SUBTITLE

Final Report of FMVSS 206 Compliance Testing of Sliding Side Door
from a 20XX Safe Rider Van

Block 5 — REPORT DATE

Month Day, 20XX

Block 6 — PERFORMING ORGANIZATION CODE

ABC

Block 7 — AUTHOR(S)

John Smith, Project Manager
Bill Doe, Project Engineer

Block 8 — PERFORMING ORGANIZATION REPORT NUMBER

206-ABC-20XX-001

14. REPORTS....Continued

Block 9 — PERFORMING ORGANIZATION NAME AND ADDRESS

ABC Laboratories
405 Main Street
Detroit, MI 48070-1234

Block 10 — WORK UNIT NUMBER

Leave blank

Block 11 — CONTRACT OR GRANT NUMBER

DTNH22-XX-D-12345

Block 12 — SPONSORING AGENCY NAME AND ADDRESS

United States Department of Transportation
National Highway Traffic Safety Administration
Office of Vehicle Safety Compliance
Mail Code: NVS-220
1200 New Jersey Avenue, SE
Washington, DC 20590

Block 13 — TYPE OF REPORT AND PERIOD COVERED

Final Test Report
Month Day to Month Day, 20XX

Block No. 14 — SPONSORING AGENCY CODE

NVS-220

Block 15 — SUPPLEMENTARY NOTES

Leave blank

14. REPORTS....Continued

Block 16 — ABSTRACT

Compliance tests were conducted on the subject 20XX Safe Rider Van in accordance with the specifications of the Office of Vehicle Safety Compliance Test Procedure No. TP-206S-01. Test failures identified were as follows:

None

NOTE: Above wording must be shown with appropriate changes made for a particular compliance test. Any questions should be resolved with the COTR.

Block 17 — KEY WORDS

FMVSS 206
Door Locks and Door Retention Components
Sliding Side Door Transverse Load Test

Block 18 — DISTRIBUTION STATEMENT

Copies of this report are available from

National Highway Traffic Safety Administration
Technical Information Services Division, NPO-411
1200 New Jersey Ave., SE (Rm E12-100)
Washington, DC 20590
FAX No.: 202-493-2833
Email: tis@nhtsa.dot.gov

Block 19 — SECURITY CLASSIFICATION OF REPORT

Unclassified

Block 20 — SECURITY CLASSIFICATION OF PAGE

Unclassified

Block 21 — NUMBER OF PAGES

Add appropriate number

14. REPORTS....Continued

Block 22 — PRICE

Leave blank

14.3.4 TABLE OF CONTENTS

Final test report Table of Contents shall include the following:

Section

- 1 Purpose of Compliance Test
- 2 Test Notes / Deviations
- 3 Compliance Test Data
- 4 Test Equipment List and Calibration Records
- 5 Interpretations or Deviations from FMVSS No. 206
- 6 Photographs

Data Sheets

- 1 Vehicle Inspection Data
- 2 Summary of Test Results
- 3 Transverse Load verses Time Graph
- 4 Loading Plate Displacement verses Time Graph

15. REPORT SECTIONS and DATA SHEETS

SECTION 1

PURPOSE OF COMPLIANCE TEST

The tests performed are part of the safety compliance program for the National Highway Traffic Safety Administration (NHTSA) by ABC under Contract No. DTNH22-XX-D-12345. The purpose of the testing is to determine whether production motor vehicle sliding side door systems meet the minimum sliding side door transverse load test requirements of TP-206S-01, "Door Locks and Door Retention Components, Sliding Side Door Transverse Load Test". The testing was conducted in accordance with the ABC testing procedure submitted to and approved by NHTSA along with the Office of Vehicle Safety Compliance Test Procedure No. TP-206S-01.

15. REPORT SECTIONS and DATA SHEETS....Continued

**SECTION 2
TEST NOTES / DEVIATIONS**

15. REPORT SECTIONS and DATA SHEETS....Continued

**SECTION 3
COMPLIANCE TEST DATA**

DATA SHEET 1
VEHICLE INSPECTION DATA - FMVSS 206

TEST GROUP NO.: _____ ; INSPECTION DATE: _____

Testing Laboratory: _____

Laboratory Technician(s): _____

Vehicle Manufacturer: _____

Vehicle Year/Make/Model: _____

Date of Manufacture: _____

Vehicle Vin: _____

Vehicle Certified As: _____

Vehicle Total GVWR: _____

Number of Latches on Each Edge of Driver Side Sliding Door:

Forward edge: _____

Rear edge: _____

Number of Latches on Each Edge of Passenger Side Sliding Door:

Forward edge: _____

Rear edge: _____

Each sliding side door contains at least one primary door latch system (i.e. contains latch equipped with both a fully latched position and secondary latched position, and designated as primary by the manufacturer), or a door latch system with a fully latched position and a door closure warning system visible by the driver: _____

COMMENTS:

RECORDED BY: _____

DATE: _____

APPROVED BY: _____

15. REPORT SECTIONS and DATA SHEETS....Continued

DATA SHEET 2

SLIDING SIDE DOOR
TRANSVERSE LOAD TEST

SUMMARY OF TEST RESULTS

TEST GROUP NO.: _____ ;

TEST DATE: _____

INDICATE P - PASS OR F - FAIL

Vehicle Year, Make and Model: _____

Group No.	Sliding Side Door Location	Door Load Location	Time Range to Max. Load (sec)	Applied Time to Max. Load (Sec)	Maximum Load (N)	Applied Test Load (N)	Failure Mode	Pass/Fail*
	Driver Side	Forward Edge	90 - 120		9,000			
		Aft Edge	90 - 120		9,000			
	Passenger Side	Forward Edge	90 - 120		9,000			
		Aft Edge	90 - 120		9,000			

* PASS/FAIL criteria shall be based upon FMVSS 206 requirements per S4.2.2.

REMARKS:

RECORDED BY: _____

DATE: _____

APPROVED BY: _____

15. REPORT SECTIONS and DATA SHEETS....Continued

DATA SHEET 3

SLIDING SIDE DOOR
TRANSVERSE LOAD TEST

Transverse Load verses Time Graph

TEST GROUP NO.: _____ ;

TEST DATE: _____

Vehicle Year, Make and Model: _____

(Insert transverse load (N) verses time (sec) graph for each door edge loading plate)

15. REPORT SECTIONS and DATA SHEETS....Continued

DATA SHEET 4

SLIDING SIDE DOOR
TRANSVERSE LOAD TEST

Loading Plate Displacement verses Time Graph

TEST GROUP NO.: _____ ;

TEST DATE: _____

Vehicle Year, Make and Model: _____

(Insert displacement (mm) verses time (sec) graph for each door edge loading plate)

15. REPORT SECTIONS and DATA SHEETS...Continued

SECTION 4
EQUIPMENT LIST AND CALIBRATION RECORD

TEST GROUP NO.: _____ ; INSPECTION DATE: _____

TESTING LABORATORY: _____

NOTE: Information to be included for each item of test instrumentation is as follows:

EQUIPMENT DESCRIPTION:

EQUIPMENT MANUFACTURER: _____

TYPE AND/OR MODEL: _____

SERIAL NUMBER: _____

LIMITS: _____

ACCURACY: _____

FREQUENCY OF CALIBRATION: _____

EXPIRATION OF CALIBRATION: _____

USED ON TEST NUMBER: _____

REMARKS:

RECORDED BY: _____ ;

DATE: _____

APPROVED BY: _____

16. FORMS

LABORATORY NOTICE OF TEST FAILURE TO OVSC

FMVSS 206

TEST DATE: _____

LABORATORY: _____

CONTRACT NO.: _____; DELV. ORDER NO: _____

LABORATORY PROJECT ENGINEER'S NAME: _____

VEHICLE MANUFACTURER: _____

VEHICLE MAKE, MODEL AND YEAR: _____

TEST FAILURE DESCRIPTION:

FMVSS REQUIREMENT, PARAGRAPH:

NOTIFICATION TO NHTSA (COTR): _____

DATE: _____

BY: _____

REMARKS:

16. FORMS....Continued

Monthly Report
Sliding Side Door
FMVSS No. 206

Group No.	Vehicle Manufacturer	Vehicle Year/Make/Model	Date Rec'd	Date Test/Preparation Started	Date Test Done	Report Sent Date

REMARKS:

