

U.S. DEPARTMENT OF TRANSPORTATION
NATIONAL HIGHWAY TRAFFIC SAFETY ADMINISTRATION

LABORATORY TEST PROCEDURE

FOR

FMVSS 216

Roof Crush Resistance



ENFORCEMENT
Office of Vehicle Safety Compliance
Room 6111, NVS-220
400 Seventh Street, SW
Washington, DC 20590

OVSC LABORATORY TEST PROCEDURE NO. 216
TABLE OF CONTENTS

	PAGE
1. PURPOSE AND APPLICATION.....	1
2. GENERAL REQUIREMENTS.....	1
3. SECURITY	4
4. GOOD HOUSEKEEPING	4
5. TEST SCHEDULING AND MONITORING	4
6. TEST DATA DISPOSITION.....	4
7. GOVERNMENT FURNISHED PROPERTY (GFP).....	5
8. CALIBRATION OF TEST INSTRUMENTS.....	5
9. PHOTOGRAPHIC DOCUMENTATION	6
10. DEFINITIONS.....	7
11. PRETEST REQUIREMENTS	7
12. TEST EQUIPMENT	8
13. PRETEST PREPARATION	10
14. STATIC LOAD TEST	13
15. POST TEST REQUIREMENTS.....	15
16. REPORTS	17
17. DATA SHEETS.....	24
18. FORMS	30

**REVISION CONTROL LOG
FOR OVSC LABORATORY
TEST PROCEDURES**

TP-216

TEST PROCEDURE		FMVSS 216		DESCRIPTION
REV. No.	DATE	AMENDMENT	EFFECTIVE DATE	
00				Original release signed by O.D.
01				
02				
03				
04	8/1/89	64FR54226	8/1/89	
05	11/01/2006	Various		Updated TP tie-down procedure, figures, text and Data Sheets.
06				
07				
08				
09				
10				
11				
12				

1. PURPOSE AND APPLICATION

The Office of Vehicle Safety Compliance (OVSC) is providing this Laboratory Test Procedure (TP) for the use of its contractor laboratories. The purpose of this TP is to provide guidelines for obtaining data in OVSC compliance testing programs and a uniform data recording format. This TP does not limit a laboratory's testing methods to the procedures specified in the TP or specific brands of testing equipment. However, any deviation from the TP's testing procedures or recommended testing equipment must be approved by the Contracting Officer's Technical Representative (COTR).

The data obtained in an OVSC compliance test are used to determine if the test specimen, a specific vehicle or item of motor vehicle equipment, meets the requirements specified in the TP. In some cases the TP does not include all of the various minimum performance requirements that are part of the associated Federal Motor Vehicle Safety Standard (FMVSS). Recognizing applicable test tolerances, the TP may specify test conditions that are less severe than the minimum requirements specified in the FMVSS.

If a contract laboratory views any part of the TP to be in conflict with the associated FMVSS or observes deficiencies in the TP, the contract laboratory shall advise the COTR and resolve the discrepancy prior to the start or resumption of compliance testing.

Legal Note: The OVSC Test Procedures are prepared for the limited purpose of use by independent laboratories under contract to conduct compliance tests for the OVSC. The TPs are not rules, regulations or NHTSA interpretations regarding the FMVSS. The TPs are not intended to limit the requirements of the applicable FMVSS(s). In addition the TPs may be modified by the OVSC at any time without notice, and the COTR may direct or authorize contractors to deviate from these procedures, as long as the tests are performed in a manner consistent with the FMVSS itself and within the scope of the contract. TPs may not be relied upon to create any right or benefit in any person. Therefore, compliance of a vehicle or item of motor vehicle equipment is not guaranteed if the manufacturer limits its certification tests to those described in the TP.

2. GENERAL REQUIREMENTS

FMVSS 216, Roof Crush Resistance, establishes strength requirements for the passenger compartment roof of passenger cars, multipurpose passenger vehicles, trucks and buses with a GVWR of 2722 kilograms or less. The purpose of the standard is to reduce deaths and injuries due to the crushing of the roof into the passenger compartment in rollover accidents. The standard does not apply to school buses and passenger cars that conform to the dynamic rollover test requirements of FMVSS 208, Occupant Crash Protection, S5.3 by means that require no action by passenger car occupants. It also does not apply to convertibles, except for optional compliance with the standard as an alternative to the rollover test requirements in S5.3 of FMVSS 208.

The prescribed static loading device is a rigid unyielding rectangular block 762 millimeters by 1,829 millimeters. It shall not move more than 127 millimeters to achieve the specified resistive load when applied to the forward edge of a vehicle's roof – see Figures 1 and 2. The resistive load to be achieved is 1½ times the unloaded vehicle

weight (UVW) of the test vehicle or 22,240 Newtons, whichever is less. Both the left and right front portions of the vehicle's roof structure shall be capable of meeting the requirements but a particular passenger car need NOT meet further requirements after being tested at one location. The passenger car's sills shall be placed on a rigid horizontal surface and fixed rigidly in position. The vehicle's windows shall be closed and the doors shall be locked. Any convertible top or removable roof structure shall be secured in place over the occupant compartment. Remove roof racks or other non-structural components.

The force shall be applied in a downward direction perpendicular to the lower surface of the static loading device at a rate of not more than 13 millimeters per second until reaching the compliant resistive load. The test shall be completed within 120 seconds. The static loading device shall be guided throughout the test so that it moves, without rotation, in a straight line with its lower surface oriented as follows and as shown in Figures 1 and 2 on the next page:

- A. Its longitudinal axis is at a forward angle (side view) of 5° below the horizontal, and is parallel to the vertical plane through the vehicle's longitudinal centerline.
- B. Its lateral axis is at a lateral outboard angle, in the front view projection, 25° below the horizontal.
- C. Its lower surface is tangent to the surface of the vehicle.
- D. The initial contact point, or center of the initial contact area, is on the longitudinal centerline of the lower surface of the static loading device and 254 millimeters from the forward most point of the centerline.
- E. If the vehicle being tested is a multipurpose passenger vehicle, truck, or bus that has a raised roof or altered roof, and the initial contact point of the static loading device is on the raised roof or altered roof to the rear of the roof over the front seat area, the plate is positioned so that the midpoint of the rearward edge of the lower surface of the static loading device is within 10 mm of the transverse vertical plane located at the rear of the roof over the front seat area.

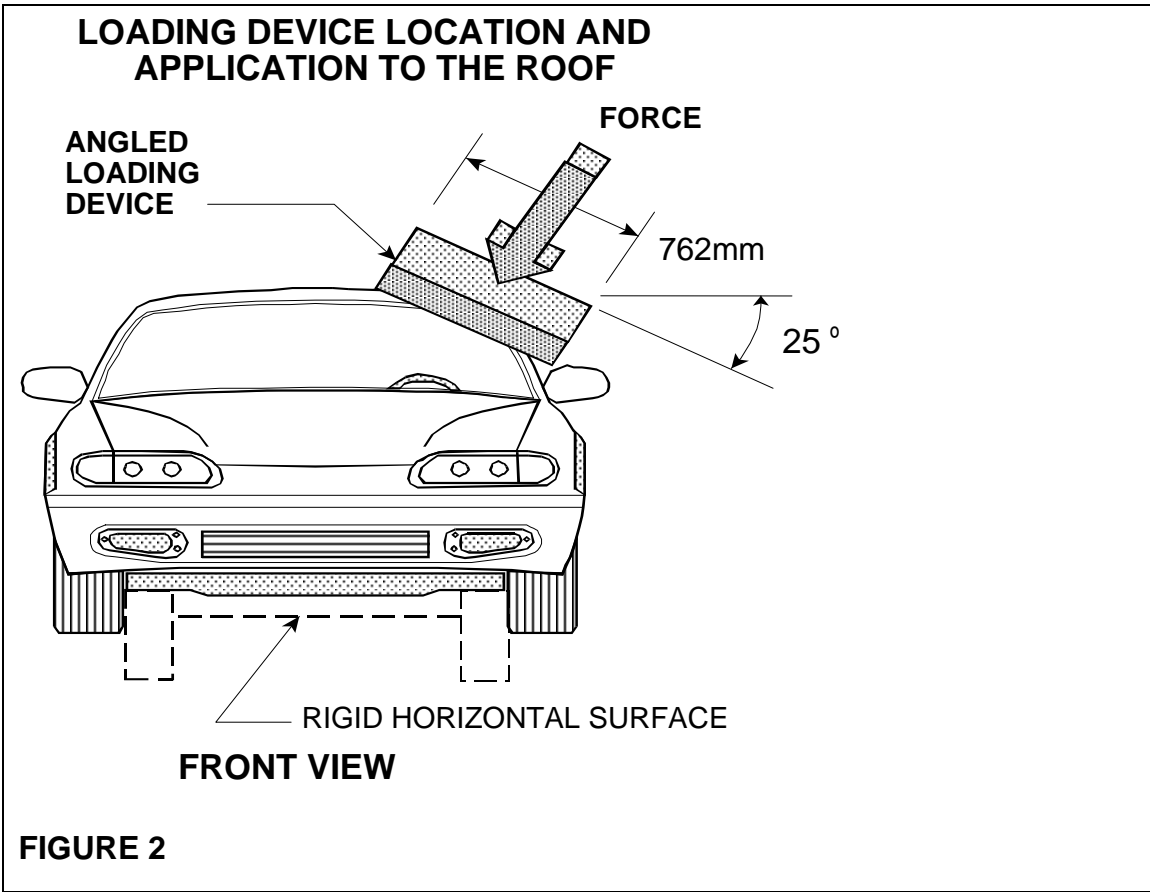
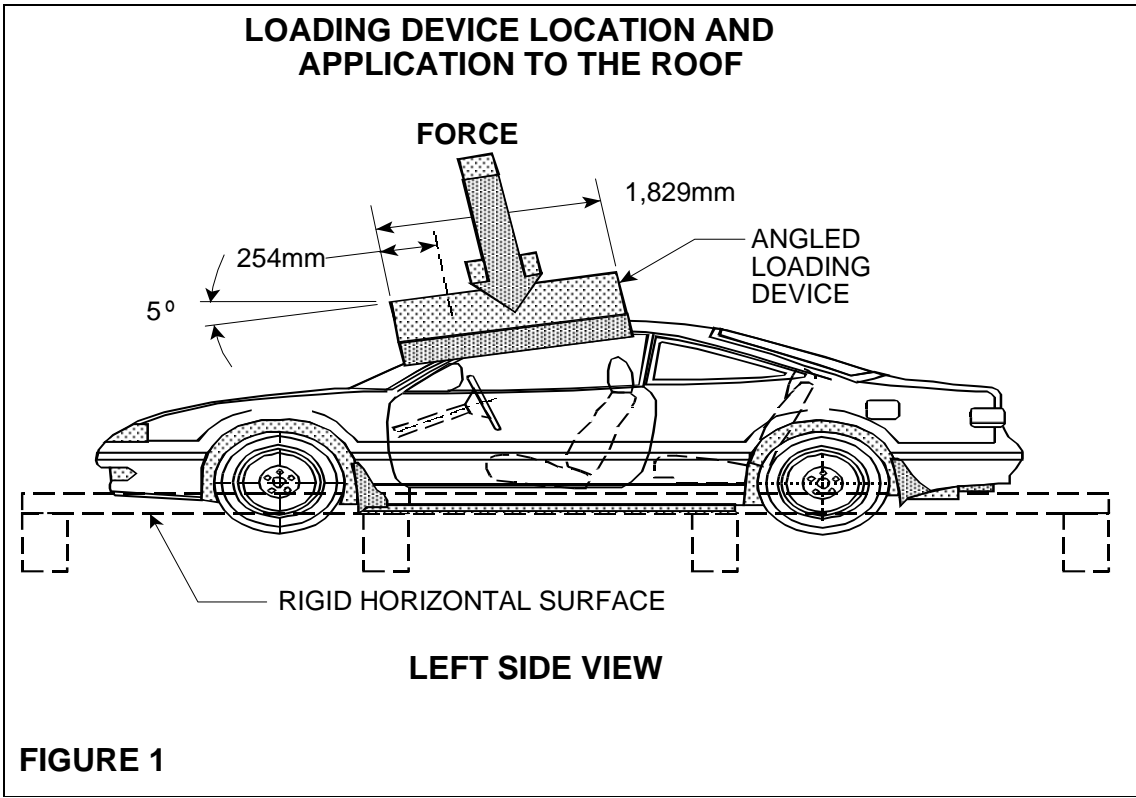

3. SECURITY

The contractor shall provide appropriate security measures to protect the OVSC test vehicles from unauthorized personnel during the entire compliance testing program. The contractor is financially responsible for any acts of theft and/or vandalism which occur during the storage of test vehicles. Any security problems which arise shall be reported by telephone to the Industrial Property Manager (IPM), Office of Contracts and Procurement, within two working days after the incident. A letter containing specific details of the security problem will be sent to the IPM (with copy to the COTR) within 3 working days.

The contractor shall protect and segregate the data that evolves from compliance testing before and after each vehicle test. No information concerning the vehicle safety compliance testing program shall be released to anyone except the COTR, unless specifically authorized by the COTR or the COTR's Division Chief.

NO INDIVIDUALS, OTHER THAN CONTRACTOR PERSONNEL DIRECTLY INVOLVED IN THE COMPLIANCE TESTING PROGRAM, SHALL BE ALLOWED TO WITNESS ANY VEHICLE COMPLIANCE TEST UNLESS SPECIFICALLY AUTHORIZED BY THE COTR.

4. GOOD HOUSEKEEPING

Contractors shall maintain the entire vehicle compliance testing area, test fixtures and instrumentation in a neat, clean and painted condition with test instruments arranged in an orderly manner consistent with good test laboratory housekeeping practices.

5. TEST SCHEDULING AND MONITORING

The contractor shall submit a test schedule to the COTR prior to testing. Tests shall be completed as required in the contract. Scheduling shall be adjusted to permit sample motor vehicles to be tested to other FMVSS as may be required by the OVSC. All testing shall be coordinated to allow monitoring by the COTR.

6. TEST DATA DISPOSITION

The contractor shall make all vehicle preliminary compliance test data available to the COTR on location within four hours after the test. Final test data, including digital printouts and computer generated plots (if applicable), shall be furnished to the COTR within five working days. Additionally, the contractor shall analyze the preliminary test results as directed by the COTR.

All data sheets, strip charts, recordings, plots, technician's notes, etc., shall be either sent to the COTR or destroyed at the conclusion of each delivery order, purchase order, etc.

7. GOVERNMENT FURNISHED PROPERTY (GFP)

ACCEPTANCE OF TEST VEHICLES

The Contractor has the responsibility of accepting test vehicles from either new car dealers or vehicle transporters. In both instances, the contractor acts in the OVSC's behalf when signing an acceptance of test vehicles. If a vehicle is delivered by a dealer, the contractor must check to verify the following:

- A. All options listed on the "window sticker" are present on the test vehicle.
- B. Tires and wheel rims are the same as listed.
- C. There are no dents or other interior or exterior flaws.
- D. The vehicle has been properly prepared and is in running condition.
- E. The glove box contains an owner's manual, warranty document, consumer information, and extra set of keys.
- F. The roof and supporting structures such as the doors and windows should be checked for proper operation and any discrepancies which may influence the testing.

If the test vehicle is delivered by a government contracted transporter, the contractor should check for damage and/or theft which may have occurred during transit.

A "Vehicle Condition" form will be supplied to the contractor by the COTR when the test vehicle is transferred from the new car dealer or between test contracts. The contractor will complete a Vehicle Condition form for each vehicle and deliver it to the COTR with the Final Test Report or the report will NOT be accepted for payment,

NOTIFICATION OF COTR

The COTR must be notified within 24 hours after a vehicle has been delivered.

8. CALIBRATION OF TEST INSTRUMENTS

Before the contractor initiates the safety compliance test program, a test instrumentation calibration system will be implemented and maintained in accordance with established calibration practices. At the minimum, the calibration system shall comply with the following:

- A. Standards for calibrating the measuring and test equipment shall be stored and used under appropriate environmental conditions to assure their accuracy and stability.
- B. All measuring instruments and standards shall be calibrated by the contractor or a commercial facility, against a higher order standard at periodic intervals NOT

TO EXCEED TWELVE (12) MONTHS! Records showing the traceability of the calibration to the National Institute of Standards and Technology (NIST) shall be maintained for all measuring and test equipment.

- C. All measuring and test equipment and measuring standards shall be labeled with the following information:
- (1) Date of calibration
 - (2) Date of next scheduled calibration
 - (3) Name of the technician who calibrated the equipment
- D. The contractor shall provide a written calibration procedure, which, as a minimum, includes the following information for all measuring and test equipment:
- (1) Type of equipment, manufacturer, model number, etc.
 - (2) Measurement range
 - (3) Accuracy
 - (4) Calibration interval
 - (5) Type of standard used to calibrate the equipment (calibration traceability of the standard must be evident)
- E. Records of calibration for all test instrumentation shall be kept by the contractor in a manner which assures the maintenance of established calibration schedules. All such records shall be readily available for inspection when requested by the COTR. The calibration system will need the acceptance of the COTR before the test program commences.

Further guidance is provided in the International Standard ISO 10012-1, "Quality Assurance Requirements for Measuring Equipment" and American National Standard ANSI/NCSL Z540-1, "Calibration Laboratories and Measuring and Test Equipment – General Requirements."

9. PHOTOGRAPHIC DOCUMENTATION

Photographs shall be color, 8 x 10 inches, and legible. A tag, label or placard identifying the test vehicle model and NHTSA number shall appear in each photograph and be legible. Each photograph shall be labeled as to subject matter. As a minimum the following photographs shall be included:

- A. ¾ Forward View of Vehicle on Tested Side Before Testing
- B. ¾ Rearward View of Vehicle on Tested Side Before Testing
- C. Left Side View of Vehicle Before Testing

- D. Right Side View of Vehicle Before Testing
- E. Front View of Test Set-up Pre-Test
- F. Left Front View of Test Set-up Pre-Test
- G. Right Front View of Test Set-up Pre-Test
- H. Vehicle in 216 Test Fixture Pre-Test
- I. Front Close-up View of the Tie-down Fixture
- J. Passenger Side Displacement Indicator Locations
- K. Driver Side Displacement Indicator Locations
- L. Interior View Pre-Test
- M. Roof Contact Point Front View
- N. $\frac{3}{4}$ Front View at Full Load
- O. $\frac{3}{4}$ Rear View at Full Load
- P. Front View of Roof Post Test
- Q. $\frac{3}{4}$ Rear View of Roof Post Test
- R. $\frac{3}{4}$ Front View of Roof Post Test
- S. Interior View Post Test
- T. Side View of Vehicle on Tested Side Post Test
- U. $\frac{3}{4}$ Front View of Vehicle Post Test
- V. $\frac{3}{4}$ Rear View of Vehicle Post Test
- W. Any Damage not Shown in Above Pictures
- X. Close-up View of Vehicle Certification Label
- Y. Close-up View of Vehicle Placard & Tire Inflation Pressure Label (if provided)
- Z. 216 Instrumentation Set-up

10. DEFINITIONS

LONGITUDINAL OR LONGITUDINALLY

Parallel to the vehicle's longitudinal centerline

UNLOADED VEHICLE WEIGHT (UVW)

Unloaded Vehicle Weight (UVW) is the weight of a vehicle with maximum capacity of all fluids necessary for operation of the vehicle, but WITHOUT cargo, occupants, or accessories that are ordinarily removed from the vehicle when they are not in use.

11. PRETEST REQUIREMENTS

Every contractor is required to submit a detailed in-house test procedure to the COTR before initiating the compliance test program. The procedure must include a step-by-step description of the methodology to be used. The contractor's test procedure shall

contain a detailed check-off sheet and a complete listing of test equipment with makes and model numbers. The list of test equipment shall include instrument accuracy and calibration dates. There shall be no contradictions between the OVSC Laboratory Test Procedure and the contractor's in-house procedure without COTR agreement. Written approval of the in-house test procedure and all subsequent revisions shall be obtained from the COTR.

TEST DATA LOSS

A compliance test is not to be conducted unless all of the various test conditions specified in the applicable OVSC Laboratory Test Procedure have been met. Failure of a contractor to obtain the required test data and to maintain acceptable limits on test parameters in the manner outlined in the applicable OVSC Laboratory Test Procedure may require a retest at the expense of the contractor. The retest costs will include the cost of the replacement test vehicle and all costs associated with conducting the retest. The original test vehicle that was used for the invalid test shall remain the property of OVSC, and the retest vehicle shall remain the property of the contractor. If there is a test failure, the contractor shall retain the retest vehicle for a period not exceeding 180 days. If there is no test failure, the Contractor may dispose of the test specimen upon notification from the COTR that the final test report has been accepted.

The Contracting Officer of NHTSA is the only NHTSA official authorized to notify the contractor that a retest is required. The retest shall be completed within two (2) weeks after receipt of notification by the Contracting Officer that a retest is required. If a retest is conducted, no test report is required for the original test.

12. TEST EQUIPMENT

Following is a list of the minimum test equipment needed to evaluate the performance requirements as outlined in S216.

A. Static Loading Device

The **Static Loading Device** will consist of a rigid, unyielding block with its lower surface formed as a flat rectangle 762 millimeters by 1,829 millimeters. The load may be applied either mechanically or hydraulically. The static loading device will be positioned with respect to the test vehicle roof as shown in Figure 2. It will have the capability of applying the required load while moving at a rate of not more than 13 millimeters per second until it has reached 127 millimeters of vehicle crush. The loading device will have the capability of traveling a minimum of 153 millimeters after initial contact with the roof.

B. Tie-Down Fixture

The vehicle must be secured on a rigid, horizontal ($\pm 0.25^\circ$) **tie-down fixture** capable of supporting the vehicle weight and the loads applied during testing without allowing any significant movement of the vehicle during the test. A procedure to secure the vehicle to the tie-down fixture is described in Pre-Test Preparation – Vehicle Preparation section below (Section 13.B)

C. Load Measuring Device

A load cell of proper capacity with an accuracy of ± 0.25 percent shall be used for measuring load and will be placed in the loading system so that it measures the actual load being transmitted into the vehicle roof. It is suggested a back-up system is used to obtain the required test data. Failure of a contractor to obtain it may require a retest at the expense of the contractor.

D. Deflection Measuring Device

Deflection of the loading device shall be measured to ± 1.5 millimeters using a linear displacement potentiometer fixed at one end and attached to the loading device at the opposite end.

E. Measurement of Displacement at the Vehicle Tie-down Fixture

Displacement dial indicators will be positioned on the driver and passenger side rocker panels to record vehicle movement. Place one (1) dial indicator on the tested side at the B-pillar, and three (3) dial indicators on the opposite side: one at the B-pillar, and the other two at the farthest points of the rocker panel (usually A and C pillars).

F. Miscellaneous Measuring Devices

Appropriate angle and length measuring instruments for determination of the orientation of the loading device and test vehicle, scales for weighing the test vehicle, and length measuring instruments for determination of the crush resistance shall be used. Scales for weighing the vehicle shall have an accuracy of ± 18 kilograms when the entire vehicle is weighted.

H. Photographic Equipment

Provide cameras and lights necessary for photographs of each test setup, test vehicle, instrumentation, and the backup systems.

I. Temperature Measuring Device

A temperature measuring instrument with an accuracy of ± 1 degree shall be used to measure the ambient temperature approximately 51 millimeters from the roof in the area of the static loading device. This measurement will be taken within 5 minutes of test initiation.

TEST EQUIPMENT ACCURACY

EQUIPMENT ITEM	RANGE	ACCURACY
Hydraulic Ram	0 - 120% of specified load	N/A
Load Cell and Signal Conditioner	0 - 120% of specified load	± 5%
X-Y Plotter (2)	Readout Capability 120% of Maximum load	± 1%
Oscillator	1 MHz	+ 1%
DC Power Supply	Adequate for Load Cell Used	Line Reg. of 0.05% (105-125v) Load Reg. of 0.05% (0-Full) Ripple: .5mv P/P Stability: 0.1%
Digital Voltmeter or Equivalent Used to Monitor Load Cell Outputs	4 Digit Readout	± 0.1%
Signal Conditioning and Calibration Unit(s)	Adequate for Load Cells Used	± 0.5%
Inclinometer	360°	+ 0.25°
Linear Displacement Potentiometer	153 millimeters	+ 0.25%
Steel Scale	At least 153 millimeters	1 millimeter
Pressure Gage	Adequate for pressure required	± 2%
Dial Indicators (2)	At least 25 millimeters travel	± 0.025 millimeters
Stop Watch	N/A	+ 0.1 Seconds
Temperature Measuring Device	-18° to 49°C	± 0.5°C
Scale	0 - 1135 kgs/wheel	+ 5 kgs/wheel

13. PRETEST PREPARATION

A. WASH AND CLEAN

Wash and clean the vehicle. Inspect test vehicle per receiving inspection procedures (Section 7) to ascertain completeness, function, and operation. Record and notify the COTR of any abnormal conditions that could influence the test results.

B. VEHICLE PREPARATION

Prior to securing the vehicle to the tie-down fixture, the following will be accomplished:

- (1) Weigh the vehicle to determine its unloaded vehicle weight (see definition)
- (2) Secure any convertible top or removable roof structure in place in the closed position.
- (3) Remove any components of the vehicle, including the vehicle wheels, that may interfere or prevent the vehicle sills from being supported on the tie-down fixture.
- (4) **Pick-Up trucks only:**
With the vehicle resting on a flat, level surface, exercise both the front and rear suspension three times and let the suspension come to rest for 5 minutes. Draw a horizontal longitudinal line at any height along each side of the vehicle from the front to the rear; transverse both the cab and cargo

- bed. This line will assist in realigning the cargo bed of the truck with the cab once the vehicle is no longer resting on the suspension components.
- (5) Prepare the surface of the rocker panel pinch weld flanges by removing any type of undercoating, cleaning and roughening the paint to ensure good adhesion for epoxy.
 - (6) If the rocker panel pinch weld flanges are vertical or approximately vertical with respect to the ground, build an **I-beam structure** to support each pinch weld flange as described below. These I-beam structures will be clamped to the tie-down fixture to support the test vehicle in place. Each I-beam structure will consist of, as a minimum, a 4-inch high steel I-beam with 1-inch by 1-inch steel box tubes welded to the top of the I-beam, leaving a 1 inch space between the box tubes. See **Figures 3 & 4**. The vehicle pinch weld flange will sit in the slot between the box tubes and this trough will be filled with epoxy. Cap the ends of the trough with putty to retain the epoxy until it cures. The I-beam structure should extend the entire length of each sill on each side of the test vehicle. If the pinch weld flange on the sill is not straight or does not allow for support by a single I-beam structure, the I-beam structure can be broken down into smaller sections that cover the entire length of the flange.

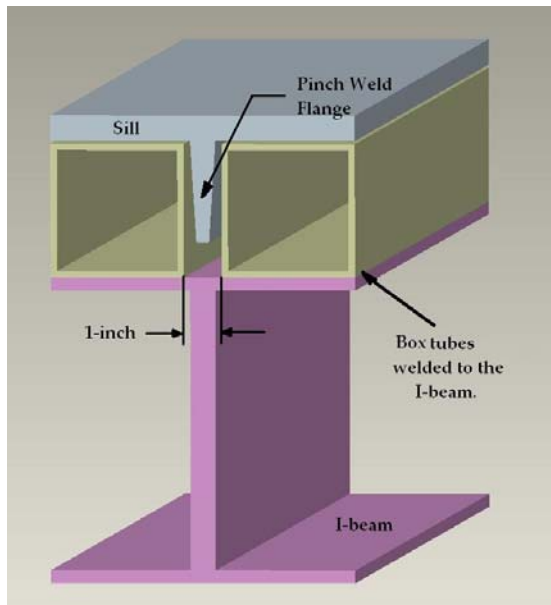

FIGURE 3



FIGURE 4

If the rocker panel pinch weld flanges are horizontal with respect to ground (or at an angle other than vertical) create a trough on top of an I-beam wide enough to hold epoxy. See **Figure 5**. A plate and different size box beams may be used to support the flange and form a trough for the epoxy. Fill the trough with epoxy and place the rocker panel pinch weld flange inside the trough so that the pinch weld is down in the epoxy. Allow the epoxy sufficient time to setup and harden (see epoxy cure time characteristics).

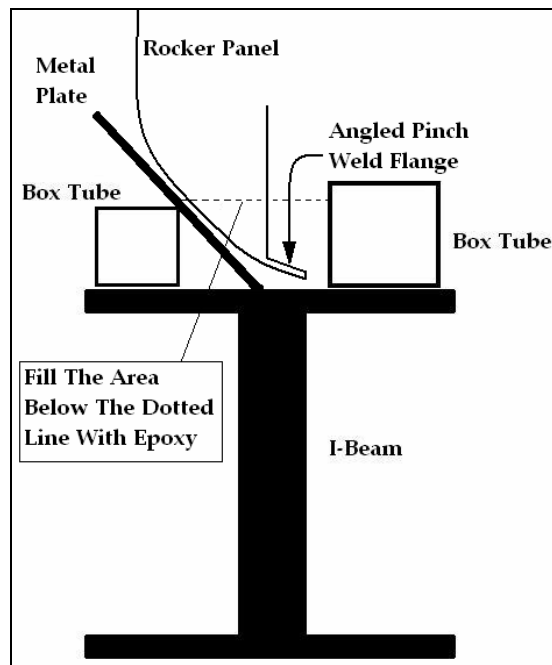

FIGURE 5 (Not to scale)

If no pinch weld flange is present on the sill of the vehicle, contact the COTR for alternatives on tie-down procedure.

NOTE: The I-beam structure dimensions stipulated above are provided simply as an example; depending on vehicle specific parameters the size of the tubing and I-beams may vary. Variation in test structure design may be required based on vehicle sill geometry.

Test experience has shown that ChockFast Gray or similar epoxy with comparable chemical properties (Compressive strength: 16,000 psi; Tensile strength: 4,000 psi) is sufficient to retain even very large vehicles during testing. Epoxy cure time is approximately 18 to 24 hours.

C. SECURE THE VEHICLE

Secure the test vehicle by clamping the I-beam structures described above to the tie-down fixture. The I-beams, and therefore the sills, should be horizontal ($0^\circ \pm 0.5^\circ$). See **Figure 6**

Additional guidelines for Pick-Up trucks:

- a. If the line previously drawn on the side of the truck is no longer co-linear between the bed and cab (or b-pillar with door), jack-up the frame under the cargo bed of the truck to bring the line on the cargo bed co-linear with the line on the cab of the truck to a best possible position.
- b. Ensure doors of the pick-up truck open and close normally without any additional force.

NOTE: Jacking of the cargo bed of the truck is intended to bring the vehicle to its “as delivered” attitude and should not add any load/flex to the cab.



FIGURE 6

D. TEST ENVIRONMENT

The vehicle test will be performed within an enclosed structure. Precautions will be taken to eliminate any heat sources that could cause temperature build-up within the closed vehicle above the ambient of the testing enclosure. The test shall be performed at an ambient temperature between -10° and 43°C .

E. MOUNT THE STATIC LOADING DEVICE

Position the static loading device as shown in Figure 7 such that:

- 1) Its longitudinal axis is at a forward angle (in side view) of 5 degrees below the horizontal, and is parallel to the vertical plane through the vehicle's longitudinal centerline;
- 2) Its transverse axis is at an outboard angle, in the front view projection, of 25 degrees below the horizontal.
- 3) Its lower surface is tangent to the surface of the vehicle; and
- 4) The initial contact point, or center of the initial contact area, is on the longitudinal centerline of the lower surface of the static loading device and 254 millimeters from the forward most point of that centerline.

F. PRETEST PHOTOGRAPHS

Take the required pretest photographs.

14. STATIC LOAD TEST

The roof of any vehicle shall be tested on one side only. The left or right side of the vehicle may be tested. Contact the COTR to determine preference.

A. DATA ACQUISITION

The following data will be recorded during testing of each vehicle roof:

- (1) Load versus displacement.
- (2) Time versus displacement
- (3) Vehicle movement at the rocker panels as recorded by the 4 dial indicators. As a minimum, record the readings from the dial indicators:
 - (A) Before load application.
 - (B) At maximum displacement of loading device travel.
 - (C) Immediately after loading device removal.

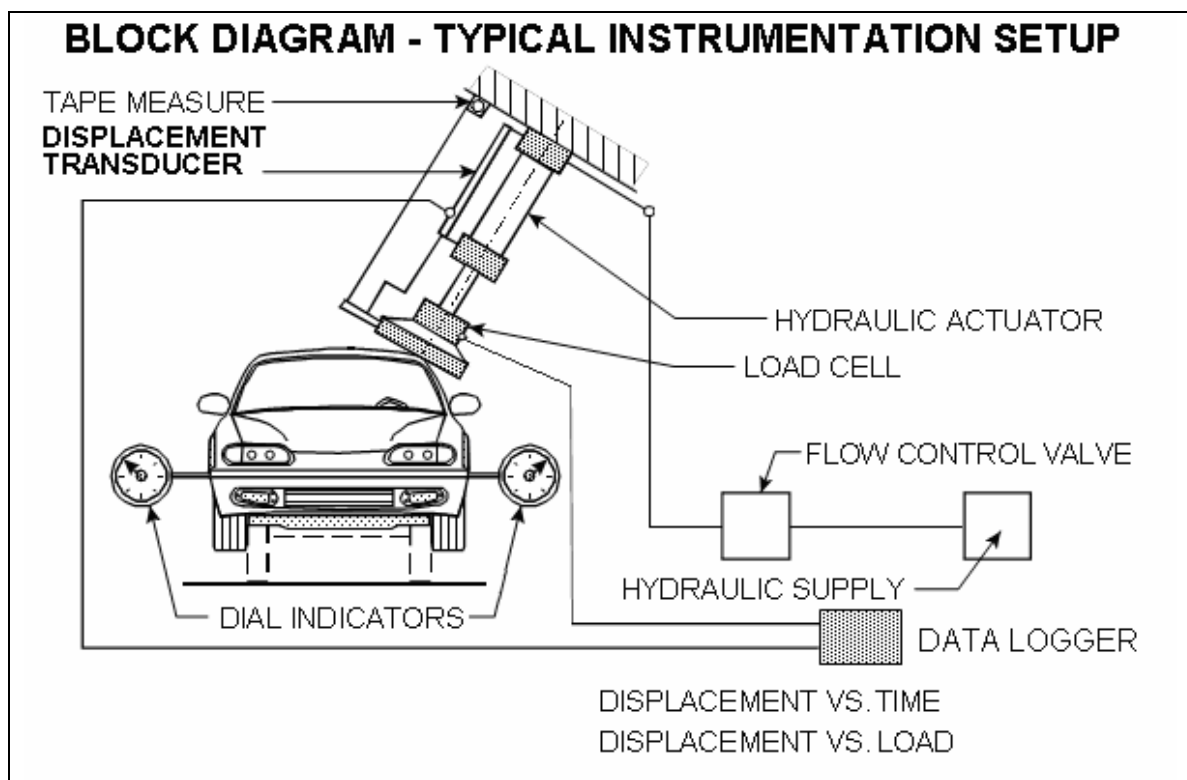

FIGURE 7

B. CRUSH RESISTANCE

Apply a load to the roof normal to the loading device after it has been positioned. Apply the load continuously at a rate not to exceed 13 millimeters per second until the loading device travels 127 millimeters. Guide the loading device to prevent it from being rotated or displaced from its intended direction of travel.

If the minimum roof crush resistance is met before the loading device travels 127 millimeters, the test shall be stopped unless the COTR provides other instructions in advance.

C. PHOTOGRAPHS

Take the necessary photographs specified in Section 9, including one of the vehicle's roof under maximum load.

15. POST TEST REQUIREMENTS

The contractor shall re-verify the operation of all instrumentation and check for the completion of data sheets and required photographs.

VISUAL OBSERVATIONS

The following information shall be recorded after testing of the roof:

Describe all damage and deformation to the roof and vehicle.

Take the required post test photographs.

MEASUREMENTS

Use the plot of force vs. displacement to directly obtain the following information:

The distance of loading device travel at which the minimum required roof crush resistance was reached.

If minimum roof crush resistance was not reached, provide the maximum roof crush resistance obtained and the distance of static loading device traveled when it was obtained.

Graphs for "DISPLACEMENT vs. TIME" and "LOAD vs. DISPLACEMENT" should be included in the Final Report. Typical test curve for FORCE vs. DISPLACEMENT is shown in Figure 8 on the next page.

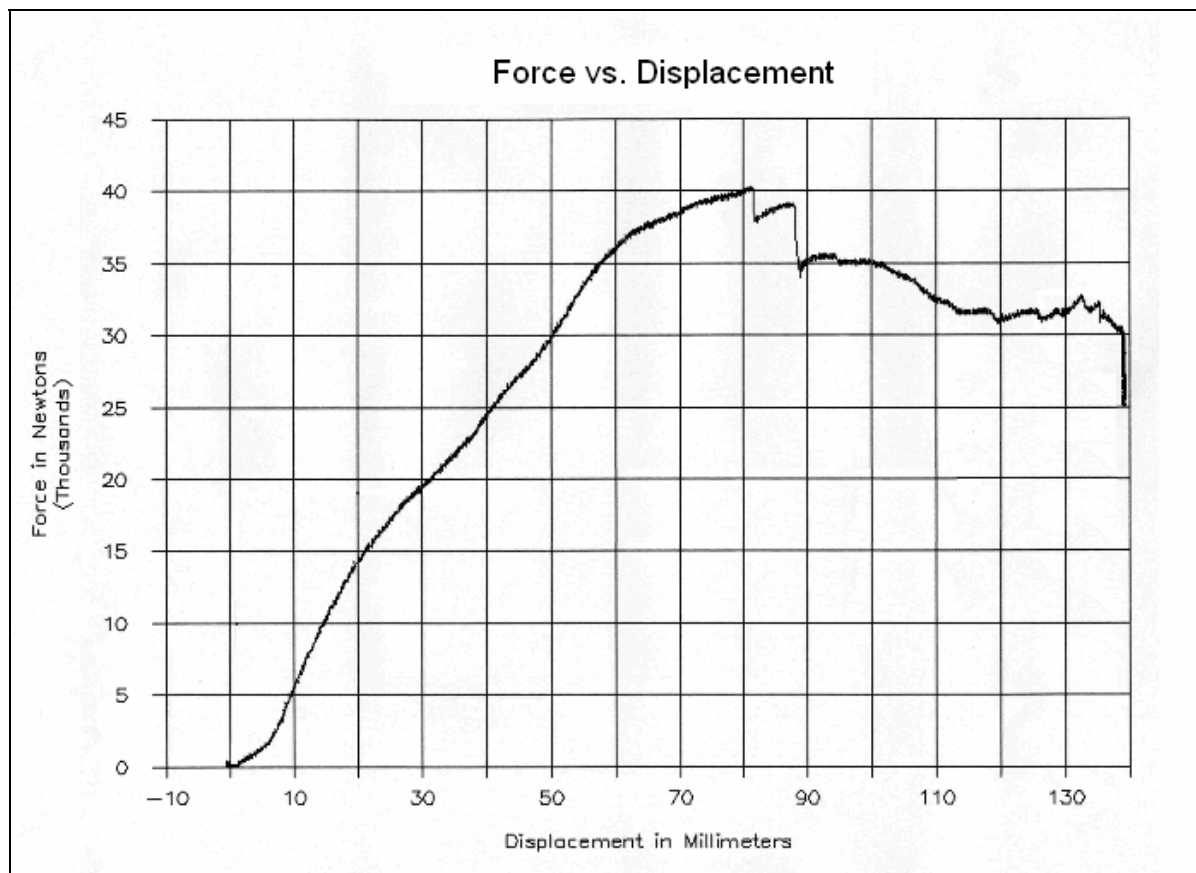
**FIGURE 8**

16. REPORTS

16.1 MONTHLY STATUS REPORTS

The contractor shall submit a monthly Test Status Report and a Vehicle Status Report to the COTR. The Vehicle Status Report shall be submitted until all vehicles are disposed of. Samples of the required Monthly Status Reports are contained in the report forms section.

16.2 APPARENT NONCOMPLIANCE

Any indication of a test failure shall be communicated by telephone to the COTR within 24 hours with written notification mailed within 48 hours (Saturdays and Sundays excluded). A Notice of Test Failure (see report forms section) with a copy of the particular compliance test data sheet(s) and preliminary data plot(s) shall be included. In the event of a test failure, a post test calibration check of some critically sensitive test equipment and instrumentation may be required for verification of accuracy. The necessity for the calibration shall be at the COTR's discretion and shall be performed without additional costs to the OVSC.

16.3 FINAL TEST REPORTS

16.3.1 COPIES

An electronic draft test report is required after completion of each test. The test report and content shall comply with the TP. The organization and content of test data sheets in the report shall be consistent with the applicable TP.

Within seven (7) days of receiving the COTR's comments on the draft test report, the Contractor shall submit up to seven (7) compact discs (at discretion of the COTR) of the final report for which the test items failed to meet the requirements of the test or the test was a retest (another test of a vehicle that previously exceeded the performance requirements). Four (4) compact discs of the final report shall be submitted for tests for which there were no failures.

Note: Prior to submission of the compact discs of the final report, the final report shall be electronically transmitted to the COTR to facilitate electronic signature for acceptance. The COTR shall sign the report then send the electronic file, containing the signature back to the contractor for the purposes of placing the file on compact disc. The final report shall be in PDF format.

The Final Test Report format to be used by all contractors can be found in Section – 16.3.2: "REQUIREMENTS".

Payment of contractor's invoices for completed compliance tests may be withheld until the Final Test Report is accepted by the COTR. Contractors are requested to NOT submit invoices before the COTR is provided copies of the Final Test Report.

Contractors are required to PROOF READ all Final Test Reports before submittal to the COTR. The OVSC will not act as a report quality control office for contractors. Reports containing a significant number of errors will be returned to the contractor for correction, and a "hold" will be placed on invoice payment for the particular test.

Electronic file copies of the Final Test Report shall be provided in accordance with the following:

- a. Electronic Master File:
An electronic version of the final report shall be used as the "Master" report copy. The hard-copy and electronic reports shall be generated from this electronic master file. A copy of the electronic master file shall be provided to NHTSA as required.
- b. System Compatibility
 1. All electronically submitted report copies shall be stored on compact discs (CD) in PDF format.
 2. The software application used to store the electronic file version (Master copy) of the final report shall be compatible with Microsoft Word, i.e., the file must be able to be opened, viewed and edited using Microsoft Word.
 3. All test report images (photographs, charts, graphs, etc.) shall be imbedded as part of a Microsoft Word file and shall be JPEG or TIFF file format.
- c. For any of the option periods exercised under this contract, NHTSA reserves the right to change the hardware and software requirements stated above, such that submitted electronic files continue to be compatible with computer systems utilized by the Office of Vehicle Safety Compliance.

If a Final Test Report is returned to the laboratory for correction, the report date shall be changed to the date of re-submission. Delivery of an unacceptable Final Test Report will not be construed as meeting the due date specified.

The data tapes recorded from the sensors during the test shall be provided on a compact disc or other acceptable media. The data shall be developed and formatted as specified by the Office of Crashworthiness Research Data References Guides. The guides can be located at NHTSA address:

<http://www-nrd.nhtsa.dot.gov/software/test-reference-guides/test-reference-guides.html>

16.3.2 REQUIREMENTS

The Final Test Report and associated documentation (including photographs) are relied upon as the chronicle of the compliance test. The Final Test Report will be released to the public domain after review and acceptance by the COTR. For these reasons, each final report must be a complete document capable of standing by itself.

The contractor should use **detailed** descriptions of all compliance test events. Any events that are not directly associated with the standard but are of technical interest

should also be included. The contractor should include as much **detail** as possible in the report.

Instructions for the preparation of the first three pages of the final test report are provided below for the purpose of standardization.

16.3.3 FIRST THREE PAGES

A. FRONT COVER —

A heavy paperback cover (or transparency) shall be provided for the protection of the final report. The information required on the cover is as follows:

- (1) Final Report Number such as 216-ABC-9X-001 where
 216 is the FMVSS tested
 ABC are the initials for the laboratory
 9X is the Fiscal Year of the test program
 001 is the Group Number (001 for the 1st test,
 002 for the 2nd test, etc.)

- (2) Final Report Title And Subtitle such as

SAFETY COMPLIANCE TESTING FOR FMVSS 216
 Roof Crush Resistance —
 Passenger Cars
 * * * * *
 World Motors Corporation
 199X Ace Super Coupe
 NHTSA No. CX0401

- (3) Contractor's Name and Address such as

COMPLIANCE TESTING LABORATORIES, INC.
 4335 West Dearborn Street
 Detroit, Michigan 48090

NOTE: DOT SYMBOL WILL BE PLACED BETWEEN ITEMS (3) AND (4)

- (4) Date of Final Report completion
- (5) The words "FINAL REPORT"
- (6) The sponsoring agency's name and address as follows

U. S. DEPARTMENT OF TRANSPORTATION
 National Highway Traffic Safety Administration
 Enforcement
 Office of Vehicle Safety Compliance
 400 Seventh Street, SW
 Room 6111 (NVS-220)
 Washington, DC 20590

B. FIRST PAGE AFTER FRONT COVER —

A disclaimer statement and an acceptance signature block for the COTR shall be provided as follows:

This publication is distributed by the U. S. Department of Transportation, National Highway Traffic Safety Administration, in the interest of information exchange. The opinions, findings and conclusions expressed in this publication are those of the author(s) and not necessarily those of the Department of Transportation or the National Highway Traffic Safety Administration. The United States Government assumes no liability for its contents or use thereof. If trade or manufacturers' names or products are mentioned, it is only because they are considered essential to the object of the publication and should not be construed as an endorsement. The United States Government does not endorse products or manufacturers.

Prepared By: _____

Approved By: _____

Approval Date: _____

FINAL REPORT ACCEPTANCE BY OVSC:

Accepted By: _____

Acceptance Date: _____

C. SECOND PAGE AFTER FRONT COVER —

A completed Technical Report Documentation Page (Form DOT F1700.7) shall be completed for those items that are applicable with the other spaces left blank. Sample data for the applicable block numbers of the title page follows.

Block 1 — REPORT NUMBER

216-ABC-9X-001

Block 2 — GOVERNMENT ACCESSION NUMBER

Leave blank

Block 3 — RECIPIENT'S CATALOG NUMBER

Leave blank

Block 4 — TITLE AND SUBTITLE

Final Report of FMVSS 216 Compliance Testing of 199X Ace Super Coupe, NHTSA No. CX0401

Block 5 — REPORT DATE

March 1, 199X

Block 6 — PERFORMING ORGANIZATION CODE

ABC

Block 7 — AUTHOR(S)

John Smith, Project Manager / Bill Doe, Project Engineer

Block 8 — PERFORMING ORGANIZATION REPORT NUMBER

ABC-DOT-XXX-001

Block 9 — PERFORMING ORGANIZATION NAME AND ADDRESS

ABC Laboratories
405 Main Street
Detroit, MI 48070-1234

Block 10 — WORK UNIT NUMBER

Leave blank

Block 11 — CONTRACT OR GRANT NUMBER

DTNH22-9X-D-12345

Block 12 — SPONSORING AGENCY NAME AND ADDRESS

US Department of Transportation
National Highway Traffic Safety Administration
Enforcement
Office of Vehicle Safety Compliance (NVS-220)
400 Seventh Street, SW, Room 6111
Washington, DC 20590

Block 13 — TYPE OF REPORT AND PERIOD COVERED

Final Test Report
Feb. 15 to Mar. 15, 199X

Block 14 — SPONSORING AGENCY CODE

NVS-220

Block 15 — SUPPLEMENTARY NOTES

Leave blank

Block 16 — ABSTRACT

Compliance tests were conducted on the subject 199X Ace Super 2-door coupe in accordance with the specifications of the Office of Vehicle Safety Compliance Test Procedure No. TP-216-XX. Test failures identified were as follows:

None

NOTE: Above wording must be shown with appropriate changes made for a particular compliance test. Any questions should be resolved with the COTR.

Block 17 — KEY WORDS

Compliance Testing
Safety Engineering
FMVSS 216

Block 18 — DISTRIBUTION STATEMENT

Copies of this report are available from —
National Highway Traffic Safety Administration
Technical Information Services (NPO-405)
400 Seventh Street, SW, Room 2336
Washington, DC 20590

e-mail: tis@nhtsa.dot.gov
FAX: 202-493-2833

Block 19 — SECURITY CLASSIFICATION OF REPORT

Unclassified

Block 20 — SECURITY CLASSIFICATION OF PAGE

Unclassified

Block 21 — NUMBER OF PAGES

Add appropriate number

Block 22 — PRICE

Leave blank

16.3.4 TABLE OF CONTENTS

Final test report Table of Contents shall include as a minimum the following:

- A. Section 1 — Purpose of Compliance Test
- B. Section 2 — Compliance Data Summary
- C. Section 3 — Test Data and Results – (Contractor must include a detailed description of all test events)
- D. Section 4 — Test Equipment List and Calibration Information
- E. Section 5 — Photographs
- F. Section 6 — Notice of Test Failure (if applicable)

17. DATA SHEETS

DATA SHEET 1

SUMMARY OF RESULTS

VEH. MOD YR/MAKE/MODEL/BODY: _____

VEH. NHTSA NO.: _____ ; VIN: _____

VEH. CERT DATE: _____ ; TEST DATE: _____

TEST LABORATORY: _____

OBSERVERS: _____

A. STATIC LOAD TEST OF _____ SIDE OF ROOF

(1) Unloaded Vehicle Weight (UVW) = _____ (See data sheet 2)

Minimum resistive force requirement is 1-½ times UVW or 22,240 Newtons (WHICHEVER IS LESS) to be reached at or before 127 millimeters of loading device displacement.

Minimum required resistive force = _____ Newtons (XX,XXX kg x 9.8)

		PASS	FAIL
2)	Maximum Roof Crush Resistance of _____ Newtons recorded at _____ millimeters of displacement.	_____	_____

B. POST TEST VISUAL INSPECTION

Describe all damage, structural failures and the general vehicle condition upon completion of testing.

RECORDED BY: _____
APPROVED BY: _____

DATE: _____

**DATA SHEET 2
RECEIVING INSPECTION**

VEH. MOD YR/MAKE/MODEL/BODY: _____

VEH. NHTSA NO.: _____ ; TEST DATE: _____

Upon receipt, the vehicle will be examined visually for completeness, function, and damage. The roof and supporting structures such as the doors and windows should be checked for proper operation and any discrepancies which may influence the testing. The vehicle will be weighed and the minimum roof crush resistance determined.

RESULTS:

(1) Unloaded Vehicle Weight (UVW):

Left Front _____ kgs. Left Rear _____ kgs.

Right Front _____ kgs. Right Rear _____ kgs.

Front Axle _____ kgs. Rear Axle _____ kgs.

TOTAL UVW _____ kgs.

(2) Minimum Required Roof Crush Resistance: _____

REMARKS:

RECORDED BY: _____

DATE: _____

APPROVED BY: _____

DATA SHEET 3**PRETEST PREPARATION**

VEH. MOD YR/MAKE/MODEL/BODY: _____

VEH. NHTSA NO.: _____; TEST DATE: _____

Prior to testing, the following will be accomplished:

- A. State side of roof tested _____
- B. Ambient temperature at approximately 51 millimeters from the vehicle roof in the area of the static loading device within 5 minutes of test initiation: _____ ° C

REMARKS:

RECORDED BY: _____

DATE: _____

APPROVED BY: _____

DATA SHEET 4**ADDITIONAL DATA**

VEH. MOD YR/MAKE/MODEL/BODY: _____

VEH. NHTSA NO.: _____; TEST DATE: _____

RESULTS: Plots of load versus displacement and time versus displacement showed that:

- (1) The maximum roof crush resistance achieved was _____ at _____ millimeters.
- (2) The rate of loading was _____

The dial indicators showed the following deflections:

STATIC LOADING DEVICE TRAVEL	TESTED SIDE MID	UNTESTED SIDE FRONT	UNTESTED SIDE MID	UNTESTED SIDE REAR
PRE-TEST	mm	mm	mm	mm
FULL LOAD	mm	mm	mm	mm
POST TEST	mm	mm	mm	mm

REMARKS:

RECORDED BY: _____

DATE: _____

APPROVED BY: _____

DATA SHEET 5

POST TEST VISUAL INSPECTION

VEH. MOD YR/MAKE/MODEL/BODY: _____

VEH. NHTSA NO.: _____; TEST DATE: _____

Upon completion of testing, a detailed visual inspection of the vehicle shall be made. Describe all damage and deformation that occurred during the test.

RESULTS:

REMARKS:

RECORDED BY: _____

DATE: _____

APPROVED BY: _____

DATA SHEET 6

TEST EQUIPMENT LIST

VEH. MOD YR/MAKE/MODEL/BODY: _____

VEH. NHTSA NO.: _____; VIN: _____

VEH. BUILD DATE: _____; TEST DATE: _____

TEST LABORATORY: _____

ITEM	MFR	MODEL	S/N	CALIB. PERIOD	DATE OF LAST CALIB.	ACCURACY	REMARKS

REMARKS:

RECORDED BY: _____

DATE: _____

APPROVED BY: _____

18. FORMS

LABORATORY NOTICE OF TEST FAILURE TO OVSC

FMVSS NO.: 216 TEST DATE: _____

LABORATORY: _____

CONTRACT NO.: _____; DELV. ORDER NO.: _____

LABORATORY PROJECT ENGINEER'S NAME: _____

TEST VEHICLE MODEL YEAR/MAKE/MODEL/BODY STYLE: _____

VEHICLE NHTSA NO.: _____; VIN: _____

MFR: _____; BUILD DATE: _____

TEST FAILURE DESCRIPTION: _____

FMVSS REQUIREMENT, PARAGRAPH _____ : _____

NOTIFICATION TO NHTSA (COTR) : _____

DATE: _____ BY: _____

REMARKS: _____

MONTHLY TEST STATUS REPORT

FMVSS 216

DATE OF REPORT: _____

NO.	VEHICLE NHTSA NO., MAKE & MODEL	COMPLIANCE TEST DATE	PASS/ FAIL	DATE REPORT SUBMITTED	DATE INVOICE SUBMITTED	INVOICE PAYMENT DATE
1						
2						
3						
4						
5						
6						
7						
8						
9						
10						
11						
12						
13						
14						

MONTHLY VEHICLE STATUS REPORT

FMVSS 216

DATE OF REPORT: _____

NO.	VEHICLE NHTSA NO., MAKE & MODEL	DATE OF DELIVERY	ODOMETER READING	TEST COMPLETE DATE	VEHICLE SHIPMENT DATE	ODOMETER READING
1						
2						
3						
4						
5						
6						
7						
8						
9						
10						
11						
12						
13						
14						