

TP-222-04
October 21, 2008

(For school buses manufactured from October 21, 2009 to October 21, 2011)

U.S. DEPARTMENT OF TRANSPORTATION
NATIONAL HIGHWAY TRAFFIC SAFETY ADMINISTRATION

LABORATORY TEST PROCEDURE

FOR

FMVSS 222

**School Bus Passenger Seating And
Crash Protection**



ENFORCEMENT
Office of Vehicle Safety Compliance
Mail Code: NVS 220
1200 New Jersey Avenue, SE
Washington, DC 20590

OVSC LABORATORY TEST PROCEDURE No. 222
TABLE OF CONTENTS

	PAGE
REVISION CONTROL LOG	i
PREFACE	ii
1. PURPOSE AND APPLICATION	1
2. GENERAL REQUIREMENTS	2
3. SECURITY	3
4. GOOD HOUSEKEEPING	4
5. TEST SCHEDULING AND MONITORING.....	4
6. TEST DATA DISPOSITION	4
7. GOVERNMENT FURNISHED PROPERTY (GFP).....	6
8. CALIBRATION OF TEST INSTRUMENTS	7
9. SUGGESTED TEST EQUIPMENT	8
10. PHOTOGRAPHIC DOCUMENTATION	10
11. DEFINITIONS	11
12. PRETEST REQUIREMENTS.....	17
13. COMPLIANCE TEST EXECUTION	19
14. POST TEST REQUIREMENTS	39
15. REPORTS.....	40
15.1. MONTHLY STATUS REPORTS	40
15.2. APPARENT TEST FAILURE.....	40
15.3. FINAL TEST REPORTS.....	40
15.3.1. COPIES	40
15.3.2. REQUIREMENTS	41
15.3.3. FIRST THREE PAGES	41
15.3.4. TABLE OF CONTENTS.....	46
16. DATA SHEETS	47
17. FORMS	68

APPENDIX A - SEAT BELT ASSY ANCHORAGES, S210, FOR CLASS 2 SCHOOL BUSES
APPENDIX B - OCCUPANT CRASH PROTECTION, S208, FOR CLASS 2 SCHOOL BUSES
APPENDIX C - WHEELCHAIR SECUREMENT ANCHORAGES AND DEVICES
REFERENCES - SAE J826 & SAE J383

**REVISION CONTROL LOG
FOR OVSC LABORATORY
TEST PROCEDURES**

TP-222

School Bus Passenger Seating and Crash Protection

TEST PROCEDURE		49 CFR Part 571.222		DESCRIPTION
REV. No.	DATE	AMENDMENT	EFFECTIVE DATE	
00	03/03/77			Original release signed by O.D.
01	03/31/80			Minor revisions
02	07/16/91			Minor revisions
03	07/20/93	58FR4586-99		Appendix 3 added Metric conversions
04	10/21/08	73FR62743 10/21/08 Final Rule	10/21/09	Update seat back and restraining barrier height requirement Update seat and barrier measurement procedures. Add seat cushion latching requirement. Minor revisions

PREFACE

On October 21, 2008, the National Highway Traffic Safety Administration (NHTSA) issued a final rule to upgrade Federal Vehicle Motor Safety Standard No. 222, "School bus passenger seating and crash protection." The final rule sets forth new performance requirements for school buses with a gross vehicle weight rating (GVWR) of 4,536 kilograms (10,000 pounds) or less to have lap/shoulder belts instead of the lap belts as currently required and, for larger school buses with a GVWR greater than 4,536, provisions for each State or local jurisdiction to voluntarily install seat belts. These requirements become effective to buses manufactured after October 21, 2011. The final rule also adds changes to the school bus safety requirements by raising the height of seat backs from 508 mm (20 inches) to 610mm (24 inches) on all new school buses and requiring a self-latching mechanism on seat bottom cushions that are designed to flip up or be removable without tools for school buses manufactured on or after October 21, 2009.

This test procedure addresses the seat back height and latching requirements which become effective on October 21, 2009 and applies to buses manufactured on that date and until October 21, 2011. A subsequent test procedure will be issued to address the additional requirements which become effective to school buses manufactured on or after October 21, 2011. For buses manufactured prior to October 21, 2009, the previous test procedure, TP-222-03, is applicable.

1. PURPOSE AND APPLICATION

This document is a laboratory test procedure provided by the National Highway Traffic Safety Administration (NHTSA), Office of Vehicle Safety Compliance (OVSC) for the purpose of presenting guidelines for a uniform testing data and information recording format, and providing suggestions for the use of specific equipment and procedures for contracted testing laboratories. The data correspond to specific requirements of the Federal Motor Vehicle Safety Standard(s) (FMVSS). The OVSC test procedures include requirements that are general in scope to provide flexibility for contracted laboratories to perform compliance testing and are not intended to limit or restrain a contractor from developing or utilizing any testing techniques or equipment which will assist in procuring the required compliance test data. These test procedures do not constitute an endorsement or recommendation for use of any particular product or testing method.

Prior to conducting compliance testing, contracted laboratories are required to submit a detailed test procedure to the Contracting Officer's Technical Representative (COTR) to demonstrate concurrence with the OVSC laboratory test procedure and the applicable FMVSS. If any contractor views any part of an OVSC laboratory test procedure to be in conflict with a FMVSS or observes deficiencies in a laboratory test procedure, the contractor is required to advise the COTR and resolve the discrepancy prior to the start of compliance testing or as soon as practicable. The contractor's test procedure must include a step-by-step description of the methodology and detailed check-off sheets. Detailed check-off sheets shall also be provided for the testing instrumentation including a complete listing of the test equipment with make and model numbers. The list of test equipment shall include instrument accuracy and calibration dates. All equipment shall be calibrated in accordance with the manufacturer's instructions. There shall be no contradictions between the laboratory test procedure and the contractor's in-house test procedure. Written approval of the in-house test procedures shall be obtained from the COTR before initiating the compliance test program.

NOTE: The OVSC Laboratory Test Procedures, prepared for the limited purpose of use by independent laboratories under contract to conduct compliance tests for the OVSC, are not rules, regulations or NHTSA interpretations regarding the meaning of a FMVSS. The laboratory test procedures are not intended to limit the requirements of the applicable FMVSS(s). In some cases, the OVSC laboratory test procedures do not include all of the various FMVSS minimum performance requirements. Recognizing applicable test tolerances, the laboratory test procedures may specify test conditions that are less severe than the minimum requirements of the standard. In addition, the laboratory test procedures may be modified by the OVSC at any time without notice, and the COTR may direct or authorize contractors to deviate from these procedures, as long as the tests are performed in a manner consistent with the standard itself and within the scope of the contract. Laboratory test procedures may not be relied upon to create any right or benefit in any person. Therefore, compliance of a vehicle or item of motor vehicle equipment is not necessarily guaranteed if the manufacturer limits its certification tests to those described in the OVSC laboratory test procedures.

2. GENERAL REQUIREMENTS

Federal Motor Vehicle Safety Standard (FMVSS) No. 222 establishes occupant protection requirements for school bus passenger seating and restraining barriers. The purpose of this standard is to reduce the number of deaths and the severity of injuries that result from the impact of school bus occupants against structures within the vehicle during crashes and sudden driving maneuvers.

Standard 222 applies to school buses in two separate classes:

Class 1. Vehicles with a gross vehicle weight rating of more than 4,536 kilograms, kg.

Class 2. Vehicles with a gross vehicle rating of 4,536 kg or less.

REQUIREMENTS

Class 1. All requirements under S5(a) of FMVSS 222.

NOTE:

When a wheelchair location is positioned in front of a seat on a Class 1 school bus, a restraining barrier must be provided between the seat and the wheelchair location, in order to compartmentalize the passengers in the seat.

Class 2. All requirements under S5(b) of FMVSS 222. The requirements under S5(b) specify that these vehicles must also meet the requirements of FMVSSs 208, 209, and 210 as they apply to multipurpose passenger vehicles. The requirements of standards 208 and 210 shall be met at all seating positions in a bench seat as determined per S4.1. Class 2 vehicles must also meet all the requirements under S5 of FMVSS 222 except:

2. GENERAL REQUIREMENTS....Continued

- S5.2 Restraining Barrier
 - S5.2.1 Barrier Seat Separation
 - S5.2.2 Barrier Position and Rear Surface Area
 - S5.2.3 Barrier Performance Forward

METRIC SYSTEM OF MEASUREMENT

Section 5164 of the Omnibus Trade and Competitiveness Act (Pub. L. 100-418) establishes that the metric system of measurement is the preferred system of weights and measures for trade and commerce in the United States. Executive order 12770 directs Federal agencies to comply with the Act by converting regulatory standards to the metric system after September 30, 1992. In a final rule published on March 15, 1990 (60 FR 13639), NHTSA completed the first phase of metrication, converting English measurements in several regulatory standards to the metric system. Since then, metrication has been applied to other regulatory standards (63 FR 28912).

Accordingly, the OVSC laboratory test procedures include revisions to comply with governmental directives in using the metric system. Regulatory standards converted to metric units are required to use metric measurements in the test procedures, whereas standards using English units are allowed to use English measurements or to use English measurements in combination with metric equivalents in parentheses. For any testing equipment that is not available for direct measurement in metric units, the test laboratory shall calculate the exact metric equivalent by means of a conversion factor carried out to at least five significant digits before rounding consistent with the specified metric requirement.

All final compliance test reports are required to include metric measurements for standards using metrication.

NOTE: The methodology for rounding measurement in the test reports shall be made in accordance with ASTM E29-06b, "Standard Practice for Using Significant Digits in Test Data to Determine Conformance with Specifications."

3. SECURITY

The contractor shall provide appropriate security measures to protect the OVSC test vehicles and Government Furnished Property (GFP) from unauthorized personnel during the entire compliance testing program. The contractor is financially responsible for any acts of theft and/or vandalism which occur during the storage of test vehicles and GFP. Any security problems which arise shall be reported by telephone to the Industrial Property Manager (IPM), Office of Acquisition Management, within two working days after the incident. A letter containing specific details of the security problem shall be sent to the IPM (with copy to the COTR) within 48 hours.

3. SECURITY....Continued

The contractor shall protect and segregate the data that evolves from compliance testing before and after each vehicle test. No information concerning the vehicle safety compliance testing program shall be released to anyone except the COTR, unless specifically authorized by the COTR or the COTR's Division Chief.

NOTE: No individuals, other than contractor personnel directly involved in the compliance testing program or OVSC personnel, shall be allowed to witness any vehicle or equipment item compliance test or test dummy calibration unless specifically authorized by the COTR.

4. GOOD HOUSEKEEPING

Contractors shall maintain the entire vehicle compliance testing area, fixtures and instrumentation in a neat, clean and painted condition with test instruments arranged in an orderly manner consistent with good test laboratory housekeeping practices.

5. TEST SCHEDULING AND MONITORING

The contractor shall submit a test schedule to the COTR prior to conducting the first compliance test. Tests shall be completed at intervals as required in the contract. If not specified, the first test shall be conducted within 6 weeks after receiving the first delivered unit. Subsequent tests shall be completed in no longer than 1 week intervals unless otherwise specified by the COTR.

Scheduling of tests shall be adjusted to permit vehicles (or equipment, whichever applies) to be tested to other FMVSSs as may be required by the OVSC. All compliance testing shall be coordinated with the COTR in order to allow monitoring by the COTR and/or other OVSC personnel if desired. The contractor shall submit a monthly test status report and a vehicle status report (if applicable) to the COTR. The vehicle status report shall be submitted until all vehicles are disposed of. The status report forms are provided in the forms section.

6. TEST DATA DISPOSITION

The Contractor shall make all preliminary compliance test data available to the COTR on location within 30 minutes after the test. Final test data, including digital printouts and computer generated plots (if applicable), shall be available to the COTR in accordance with the contract schedule or if not specified within two working days. Additionally, the Contractor shall analyze the preliminary test results as directed by the COTR.

All backup data sheets, strip charts, recordings, plots, technicians' notes, etc., shall be either sent to the COTR or destroyed at the conclusion of each delivery order, purchase order, etc.

The contractor shall protect and segregate the data that evolves from compliance testing before and after each test.

6. TEST DATA DISPOSITION....Continued

TEST DATA LOSS

A. INVALID TEST DESCRIPTION

An invalid compliance test is one, which does not conform precisely to all requirements/specifications of the OVSC Laboratory Test Procedure and Statement of Work applicable to the test.

B. INVALID TEST NOTIFICATION

The Contractor shall notify NHTSA of any test not meeting all requirements/specifications of the OVSC Laboratory Test Procedure and Statement of Work applicable to the test, by telephone, within 24 hours of the test and send written notice to the COTR within 48 hours of the test completion.

C. RETEST NOTIFICATION

The Contracting Officer of NHTSA is the only NHTSA official authorized to notify the Contractor that a retest is required. The retest shall be completed within 2 weeks after receipt of notification by the Contracting Officer that a retest is required.

D. WAIVER OF RETEST

NHTSA, in its sole discretion, reserves the right to waive the retest requirement. This provision shall not constitute a basis for dispute over the NHTSA's waiving or not waiving any requirement.

E. TEST VEHICLE

NHTSA shall furnish only one vehicle for each test ordered. The Contractor shall furnish the test vehicle required for the retest. The retest vehicle shall be equipped as the original vehicle. The original vehicle used in the invalid test shall remain the property of NHTSA, and the retest vehicle shall remain the property of the Contractor. The Contractor shall retain the retest vehicle for a period not exceeding 180 days if it fails the test. If the retest vehicle passes the test, the Contractor may dispose of it upon notification from the COTR that the test report has been accepted.

F. TEST REPORT

No test report is required for any test that is determined to be invalid unless NHTSA specifically decides, in writing, to require the Contractor to submit such report. The test data from the invalid test must be safeguarded until the data from the retest has been accepted by the COTR. The report and other required deliverables for the retest vehicle are required to be submitted to the COTR within 3 weeks after completion of the retest.

6. TEST DATA DISPOSITION....Continued

G. DEFAULT

The Contractor is subject to the default and subsequent reprocurement costs for nondelivery of valid or conforming test (pursuant to the Termination For Default clause in the contract).

H. NHTSA'S RIGHTS

None of the requirements herein stated shall diminish or modify the rights of NHTSA to determine that any test submitted by the Contractor does not conform precisely to all requirements/specifications of the OVSC Laboratory Test Procedure and Statement of Work applicable to the test.

7. GOVERNMENT FURNISHED PROPERTY (GFP)

A. ACCEPTANCE OF VEHICLE

The Contractor has the responsibility of accepting the test vehicle from either a dealer or a vehicle transporter. In both instances, the contractor acts in the OVSC's behalf when signing an acceptance of the test vehicle. If the vehicle is delivered by a dealer, the contractor must check to verify the following:

1. Tires and wheel rims are new and the same as listed.
2. There are no dents or other interior or exterior flaws in the vehicle body.
3. The vehicle has been properly prepared and is in running condition.
4. An owner's manual, warranty document, consumer information, and extra set of keys are included with the vehicle.
5. Proper fuel filler cap is supplied on the test vehicle.
6. Spare tire, jack, lug wrench and tool kit (if applicable) is included with the vehicle.
7. The VIN (vehicle identification number) on the vehicle matches that supplied by the COTR.
8. Seats and, if applicable, restraining barriers are not deformed.
9. The vehicle is equipped as specified by the COTR.

A Vehicle Condition form will be supplied to the Contractor by the COTR when the test vehicle is transferred from a new vehicle dealership or between test contracts. The upper half of the form is used to describe the vehicle as initially accepted. The lower half of the Vehicle Condition form provides space for a detailed description of the post-test condition. The contractor must complete a Vehicle Condition form for each vehicle and deliver it to the COTR with the Final Test Report or the report will NOT be accepted for payment.

7. GOVERNMENT FURNISHED PROPERTY (GFP)Continued

If the test vehicle is delivered by a government contracted transporter, the contractor should check for damage which may have occurred during transit. GFP vehicle(s) shall not be driven by the contractor on public roadways unless authorized by the COTR.

B. NOTIFICATION OF COTR

The COTR must be notified within 24 hours after a vehicle (and/or equipment item) has been delivered. In addition, if any discrepancy or damage is found at the time of delivery, a copy of the Vehicle Condition form shall be sent to the COTR immediately.

8. CALIBRATION OF TEST INSTRUMENTS

Before the Contractor initiates the vehicle safety compliance test program, a test instrumentation calibration system must be implemented and maintained in accordance with established calibration practices. The calibration system shall include the following as a minimum:

- A. Standards for calibrating the measuring and test equipment shall be stored and used under appropriate environmental conditions to assure their accuracy and stability.
- B. All measuring instruments and standards shall be calibrated by the Contractor, or a commercial facility, against a higher order standard at periodic intervals not exceeding 12 months for instruments and 12 months for the calibration standards except for static types of measuring devices such as rulers, weights, etc., which shall be calibrated at periodic intervals not to exceed two years. Records, showing the calibration traceability to the National Institute of Standards and Technology (NIST), shall be maintained for all measuring and test equipment.

Accelerometers shall be calibrated every twelve months or after a test failure or after any indication from calibration checks that there may be a problem with the accelerometer whichever occurs sooner.

- C. All measuring and test equipment and measuring standards shall be labeled with the following information:
 - 1. Date of calibration
 - 2. Date of next scheduled calibration
 - 3. Name of the technician who calibrated the equipment
- D. A written calibration procedure shall be provided by the Contractor, which includes as a minimum the following information for all measurement and test equipment:
 - 1. Type of equipment, manufacturer, model number, etc.

8. CALIBRATION OF TEST INSTRUMENTS....Continued

2. Measurement range
 3. Accuracy
 4. Calibration interval
 5. Type of standard used to calibrate the equipment (calibration traceability of the standard must be evident).
 6. The actual procedures and forms used to perform the calibrations.
- E. Records of calibration for all test instrumentation shall be kept by the Contractor in a manner that assures the maintenance of established calibration schedules.
- F. All such records shall be readily available for inspection when requested by the COTR. The calibration system shall need the acceptance of the COTR before vehicle safety compliance testing commences.
- G. Test equipment shall receive a system functional check out using a known test input immediately before and after the test. This check shall be recorded by the test technician(s) and submitted with the final report.
- H. The Contractor may be directed by NHTSA to evaluate its data acquisition system.

Further guidance is provided in the International Standard ISO 10012-1, "Quality Assurance Requirements for Measuring Equipment" and American National Standard ANSI/NCSL Z540-1, "Calibration Laboratories and Measuring and Test Equipment General Requirements."

NOTE: In the event of a failure to meet the standard's minimum performance requirements additional calibration checks of some critically sensitive test equipment and instrumentation may be required for verification of accuracy. The necessity for the calibration will be at the COTR's discretion and shall be performed without additional cost.

9. SUGGESTED TEST EQUIPMENT

The following is a list of the minimum suggested test equipment needed to evaluate the minimum performance requirements as outlined in FMVSS 222.

- A. Two loading bars in accordance with the requirements given in section 11, Definitions.
- B. A head form in accordance with the requirements given in section 11, Definitions.
 - (1) An acceleration sensing device whose output is recorded in a data channel that conforms to the requirements for a 1,000 Hz channel class as specified in SAE Recommended Practice J211a, Dec 1971. (S6.6.2)

9. SUGGESTED TEST EQUIPMENT....Continued

- (2) A stroking device constructed such that the direction of travel of the head form is not affected by impact with the surface being tested at the force levels called for in FMVSS 222. (S6.6.3)
 - (3) The acceleration sensing device will be oriented so that its axis of acceleration coincides with the straight line connecting the center points of the two hemispherical outer surfaces which constitute the head form shape. (S6.6.3)
- C. A knee form in accordance with the requirements given in section 11, Definitions.
- (1) An acceleration sensing device whose output is recorded in a data channel that conforms to the requirements of a 600 Hz channel class as specified in the SAE Recommended Practice J211a, Dec 1971. (S6.7.2)
 - (2) A stroking device constructed such that the direction of travel of the knee form is not affected by impact with the surface being tested at the force levels called for in FMVSS 222. (S6.7.3)
 - (3) The axis of the acceleration sensing device is aligned to measure acceleration along the centerline of the cylindrical knee form. (S6.7.1)
- D. Data recording equipment that have a sufficient number of channels available for recording the required loads. Each data channel is comprised of a sensor, signal conditioner, data acquisition device and all interconnecting cables. The knee and head impact data shall be collected by computer and be in a Windows PC compatible format.
- E. An instrument calibration system capable of performing individual tests of all data channels used in acquiring all force, deflection and acceleration data. The calibration system must conform to the appropriate section of SAE J211.
- F. A recorder to provide preliminary acceleration and force data prior to data reduction.
- G. (1) A fixture or apparatus for mounting the head form and knee form in the various positions required by the test procedure.
- (2) A test fixture for mounting the load bars in the positions required by the test procedure. The test fixture shall be mounted securely to the bus such that when the loading bar is at any test position, the pivot point will not be deflected more than 25.4 mm when a lateral or vertical load of 17,792 newtons is applied to the pivot point.

The contractor must evaluate his entire test equipment system and provide the NHTSA COTR with the overall plus or minus tolerances for approval before testing can be started.

9. SUGGESTED TEST EQUIPMENT....Continued

- H. Measuring devices to locate impact points and distances.
- I. Device or speed trap for calibrating and measuring velocity at impact.
- J. Method, procedure and equipment for measuring the contact area of the head and knee forms with the seat or other padding.

10. PHOTOGRAPHIC DOCUMENTATION**DIGITAL PHOTOGRAPHS**

The contractor shall take digital photographs of the test execution procedures. Photographs shall be taken in color and contain clear images. A tag, label or placard identifying the test item, NHTSA number (if applicable) and date shall appear in each photograph and must be legible. Each photograph shall be labeled as to the subject matter. The required resolution for digital photographs is a minimum of 1,600 x 1,200 pixels. Digital photographs are required to be created in color and in a JPG format. Glare or light from any illuminated or reflective surface shall be minimized while taking photographs.

The test reports shall include enough photographs to describe the testing in detailed and shall be organized in a logical succession of consecutive pictures. The digital photographs shall be included in the test report as 203 mm x 254 mm or 215.9 mm x 279 mm (8 x 10 or 8½ x 11 inch) pictures (or for equipment testing -- 125 mm x 175 mm (5 x 7 inch) pictures). All photographs are required to be included in the test report in the event of a test failure. Any failure must be photographed at various angles to assure complete coverage. Upon request, the photographs shall be sent to the COTR on a CD or DVD and saved in a "read only" format to ensure that the digital photographs are the exact pictures taken during testing and have not been altered from the original condition.

PHOTOGRAPHIC VIEWS

As a minimum the following test photographs shall be included in each vehicle final test report, submitted by the contractor:

- A. Left side view of school bus
- B. Right side view of school bus
- C. 3/4 frontal view from left side of school bus
- D. 3/4 rear view from right side of school bus
- E. Closeup view of the vehicle's certification label including the chassis manufacturers label if applicable.

10. PHOTOGRAPHIC DOCUMENTATION....Continued

- F. Closeup view of vehicle's tire information label
- G. Views of vehicle's interior, front to rear and rear to front
- H. Each test performed on the school bus will include the following:
 - (1) Pretest equipment setup of the head and knee form impactors, loading bars, and other test fixtures and loading devices.
 - (2) Pretest and post test condition of each seat, barrier, seat belt anchorage, wheelchair securement anchorage, and wheelchair occupant restraint anchorage that was tested
 - (3) Fit of seat belt on each applicable test dummy
 - (4) Additional photographs of any damage or noncompliance condition which cannot be seen in the above photographs

11. DEFINITIONS

ABSORBED ENERGY

Total energy minus the recoil energy.

ATTACHMENT POINT

Any point where the seat is fastened to the vehicle floor or side wall. Any point where structural components of the seat frame are joined.

BUS

Motor vehicle with motive power, except a trailer, designed for carrying more than 10 persons. Carrying capacity is determined by identifying the number of designated seating positions in the vehicle as defined in 49 CFR Part 571.3. In determining vehicle carrying capacity, wheelchair seating positions are not designated seating positions, however wheelchair positions are counted in determining vehicle seating capacity. Designated seating position uses the term person in its definition and a driver is considered a person for both the computation of designated seating positions and vehicle capacity. (571.3)

CONTACT AREA

Maximum area bounded by outline curves of the individual contact prints and non-intersecting tangent line segments between contact print outline curves. Contact prints are only those transfers resulting from contact between the head and knee forms and the test surface, as opposed to those transfers resulting from an obvious splatter of the transfer medium.

11. DEFINITIONS....Continued

CONTACTABLE SURFACE

Any surface that is contactable from any direction by the head form within the following zone:

- A. Horizontal plane 305 mm and a horizontal plane 1,016 mm above the Seating Reference Point (SRP)
- B. Vertical longitudinal plane tangent to the inboard (aisle side) edge of the seat
- C. Vertical longitudinal plane 82 mm inboard of the outboard edge of the seat
- D. Vertical transverse plane through the SRP, and a vertical transverse plane 762 mm forward of the SRP except any surface on the front of a seat back or restraining barrier 76 mm or more below the top of the seat back or restraining barrier. (S4)

FMVSS

Federal Motor Vehicle Safety Standard

FORCE-DEFLECTION ZONE

Limits within which the seat and barrier must perform during the forward force application phase of the test as shown in Figure 1. (S5.1.3(a))

SEAT BACK AND RESTRAINING BARRIER FORCE DEFLECTION ZONE (FORWARD TEST)

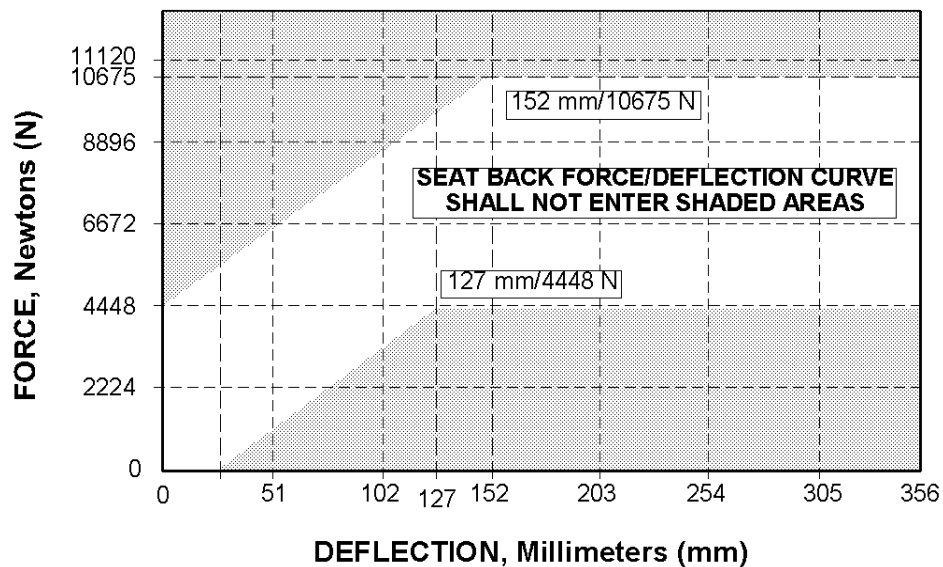

FIGURE 1

11. DEFINITIONS....Continued

GROSS VEHICLE WEIGHT RATING (GVWR)

Gross Vehicle Weight Rating means the value specified by the manufacturer as the loaded weight of a single vehicle.

HEAD FORM

Head form, shown in Figure 2, for the measurements of HIC, energy, contact area, and resisting force is a rigid surface comprised of two hemispherical shapes. The total weight of the two hemispheres and all other attachments is 5.21 Kg. The first of the two hemispherical shapes has a diameter of 164 mm. The second of the two hemispherical shapes has a 50.8 mm diameter and is centered to protrude from the outer surface of the first hemispherical shape. The surface roughness of the hemispherical shapes does not exceed 0.0016 mm, root mean square (RMS). (S6.6)

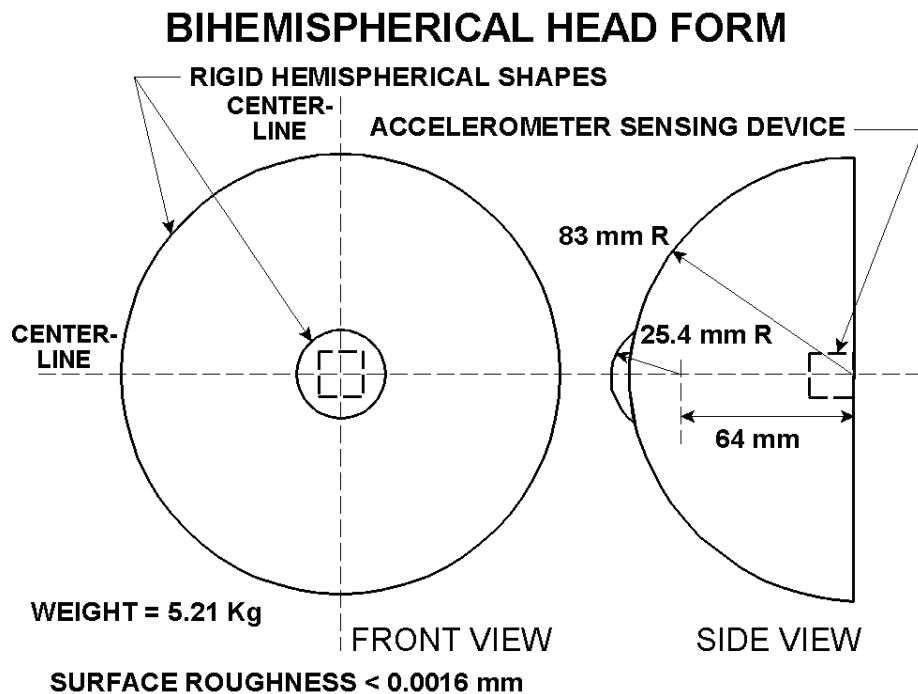

FIGURE 2

11. DEFINITIONS....Continued

KNEE FORM

Knee form, shown in Figure 3, for measurement of resisting force and contact area is a rigid 76 mm diameter cylinder, with an equivalent weight of 4.53 Kg, that has one rigid hemispherical end with a 38 mm radius forming the contact surface of the knee form. The hemispherical surface roughness does not exceed 0.0016 mm RMS. (S6.7)

KNEE FORM

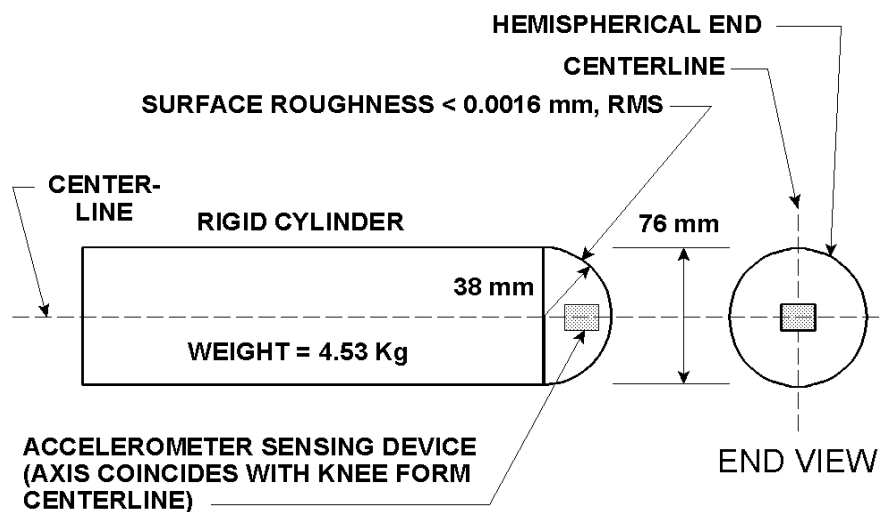

FIGURE 3

LOADING BAR

Rigid cylinder, shown in Figure 4, with an outside diameter of 152 mm that has hemispherical ends with a radii of 76 mm and with a surface roughness that does not exceed 0.0016 mm, root mean square (RMS). The length of the loading bar is 102 mm less than the width of the seat back which is measured in the horizontal plane at the required loading bar position for each test. The stroking mechanism applies force through a pivot attachment at the center point of the loading bar which allows the loading bar to rotate in a horizontal plane 30 degrees in either direction from the transverse position. (S6.5)

11. DEFINITIONS....Continued

LOADING BAR

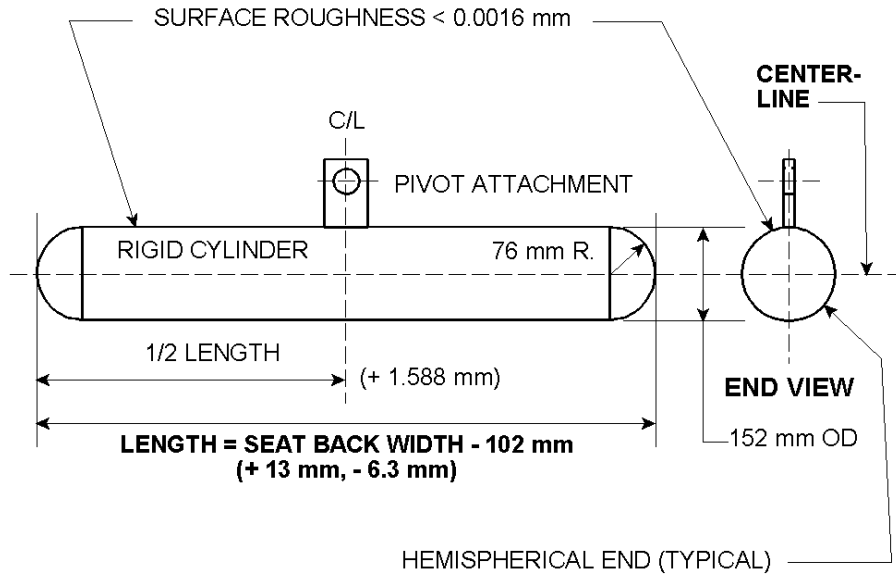

FIGURE 4

REARMOST SEAT

In cases where there are no provisions for passengers behind this seat who could impact with it in a crash situation, it has been EXEMPTED from the forward and rearward performance requirements of the standard.

SCHOOL BUS

A bus, shown in Figure 5, that is sold, or introduced into interstate commerce, for purposes that include carrying students to and from school or related events, but does not include a bus designed and sold for operation as a common carrier in urban transportation. (571.3)

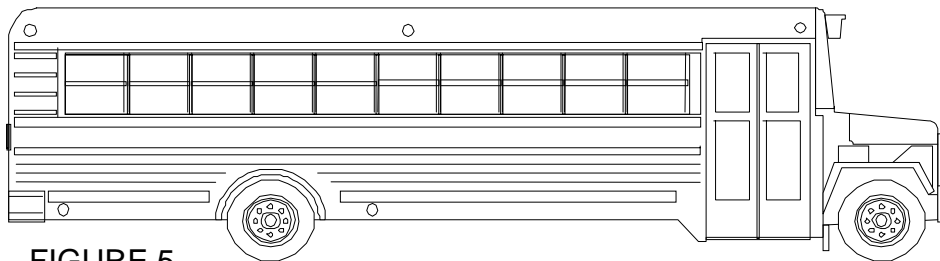

FIGURE 5

11. DEFINITIONS....Continued

SCHOOL BUS PASSENGER SEAT

Seat in a school bus, other than the driver's seat. (S4)

SEAT CUSHION SELF-LATCHING MECHANISM

A passenger seat cushion attachment device that allows for the seat cushion to be removable without tools or to flip up and is designed to latch the seat cushion to the seat frame when a mass is placed on the top center of the seat cushion with the seat cushion in the down position. S5.1.5(a)

SEATING REFERENCE POINT (SRP)

Manufacturer's design reference point which-

- A. Establishes the rearmost normal design driving or riding position of each designated seating position in a vehicle;
- B. Has coordinates established relative to the designed vehicle structure;
- C. Simulates the position of the pivot center of the human torso and thigh; and
- D. Is the reference point employed to position the two dimensional templates described in SAE Recommended Practice J826, Manikins for Use in Defining Vehicle Seating Accommodations, Nov 1962 (571.3).

STROKING DEVICE

Method to accelerate the head form or knee form to the desired velocity.

"W"

The number of seating positions considered to be in a bench seat, and is calculated as the bench width in millimeters (mm) divided by 381 and rounded to the nearest whole number. (S4.1)

12. PRETEST REQUIREMENTS

Prior to conducting a compliance test, the contractor shall:

- Verify COTR approval of Contractor's in-house test procedure,
- Verify the training of technicians for performance of this test,
- Verify the calibration status of test equipment,
- Review applicable revisions of FMVSS 222, 208, and 210.
- Review vehicle Owner's Manual (or equipment mfg. instructions), and
- Set cold tire pressures according to the vehicle manufacturer's recommendations (where applicable).

RECEIVING INSPECTION OF THE SCHOOL BUS

- A. Wash and clean the vehicle exterior and interior including all seats. Affix a placard displaying the NHTSA number to the inside the windshield and to the exterior front sides and rear of the bus. This number is the primary identification number and will remain on the vehicle throughout the test program.
- B. Place the test vehicle on a level surface.
- C. Inflate tires to manufacturer's recommended pressure for the applicable gross vehicle weight rating (GVWR).
- D. Ambient test temperature must be maintained between 0°C and 32.2°C inside the bus during testing. Temperature readings should be taken at 3 different locations within the bus interior that are approved by the OVSC COTR.
- E. It must be noted that a particular school bus passenger seat, as a test specimen, is not required to meet additional standards after having met the seat back height and surface area and the seat cushion retention requirements, or after having been subjected to either the seat back force/deflection test-forward, seat back force/deflection test-rearward, or the impact zone tests. The COTR in coordination with the testing laboratory will select the exact location and number of seats to be tested. (S5(a))
- F. If the school bus is equipped with adjustable seat backs, the back is placed in the most upright position. (S6.4)

12. PRETEST REQUIREMENTS....Continued

- G. Determine that all school bus passenger seats are forward facing. (S5.1)
- H. Note that Class 2 buses receive all the same tests as Class 1 buses except the requirements of sections S5.2, S5.2.1, S5.2.2, and S5.2.3. In addition, Class 2 buses are tested to the seat belt fit requirements of FMVSS 208 and the seat belt anchorage requirements of FMVSS 210 as shown in the appendix section. No testing to FMVSS 209 will be performed. (S5(b))
- I. Number each bus seat, including wheelchair locations, in a counter clockwise direction starting at the passenger seat or wheelchair immediately behind the driver's seat as shown in Figure 6. Each seat number for a wheelchair location shall include the letter W as shown below. Place a schematic of the seat floor plan in the final report for seat identification. Label each seat in the photographs with the number of the seat and by the NHTSA number of the school bus.

TYPICAL SCHOOL BUS SEAT FLOORPLAN

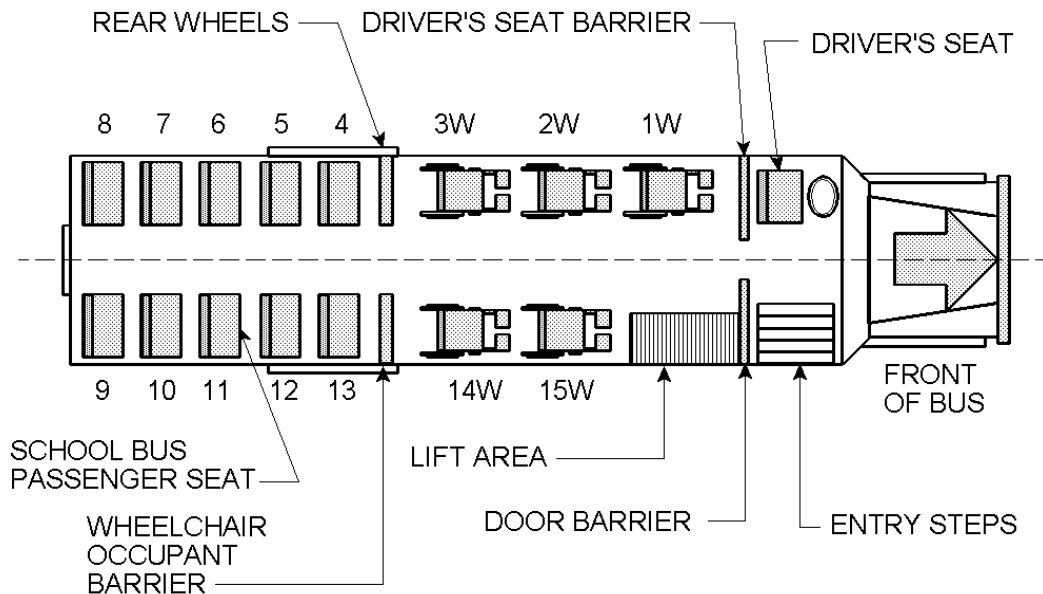

FIGURE 6

12. PRETEST REQUIREMENTS....Continued

- J. For Class 2 buses, the test vehicle's seats (including the operation of any adjustable seats) and restraint systems shall be subjected to a visual inspection to ascertain that the seats and seat belt assemblies are functional. Any damage that could influence the test results shall be recorded on the Vehicle Condition sheet, and any unusual condition shall be reported to the COTR before initiation of testing. The COTR must approve the testing of any unusual test specimen.
- K. The vehicle's interior and exterior, including all windows, seats, doors, etc., shall be subjected to visual and manual inspection to ascertain that each system is complete and functional per the manufacturer's recommendations. Any damage, deformation, maladjustments or other conditions that could influence the test results or the purpose of the test program shall be recorded. Report the nature of any abnormal condition to the OVSC COTR prior to test initiation on an abnormal specimen.
- L. Obtain color photographs of the vehicle's exterior and interior as per section 10, Photographic Documentation.
- M. Record and photograph manufacturer's certification label for the complete vehicle, and, if applicable, for the incomplete vehicle.
- N. Record vehicle general data and pretest checkout data on the Administrative Data Sheet.

13. COMPLIANCE TEST EXECUTION

13.1 LINEAR AND AREA MEASUREMENTS

- A. Check all the school bus passenger seats to determine that either a seat back or barrier is no more than 610 mm, +0, -6 mm, horizontally forward of the SRP. (S5.2.1)

Shown in Figure 7 are the space measurement requirements for the seats; use tolerance limits of ± 6 mm when locating the SRP. Record results on Data Sheet 1. (Not required for Class 2 buses)

13. COMPLIANCE TEST EXECUTION....Continued

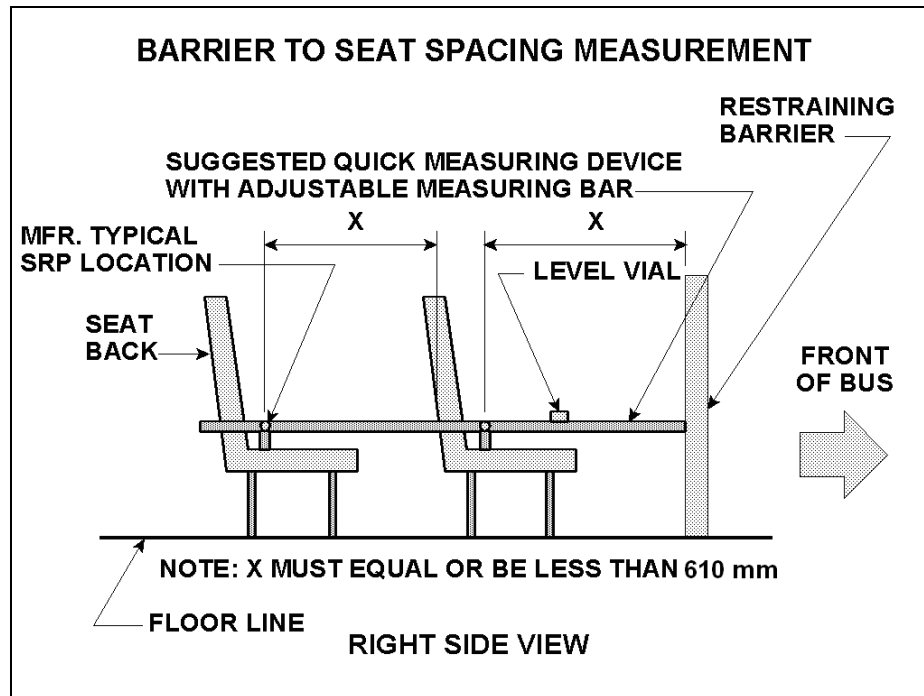

FIGURE 7

- B. Select two school bus passenger seats which represent each seat design in the bus. Project the front surface of the seat back onto a vertical transverse plane and measure the seat back height and surface area ($\pm 2\%$) as shown in Figure 8. The front surface area to be measured is that which falls between:

- (1) A horizontal plane that passes through the SRP and a horizontal plane 610 mm above the SRP; and
- (2) A vertical longitudinal plane that passes through the inboard-most point of the seat cushion and a vertical longitudinal plane that passes through the outboard-most point of the seat cushion.

Figure 8 shows the vital dimensions which must be recorded for a typical school bus passenger seat back. The area of the seat back as described above must be equal to or greater than 90 percent of the seat bench width multiplied by 610 mm. Record these measurements and computations for each seat measured on Data Sheet 2. (S5.1.2)

Measure the seat back width at 610 mm above the SRP. This dimension should be at least 75 percent of the maximum transverse width of the seat bench (W1). Record these measurements and computations for each seat measured on Data Sheet 2. (S5.1.2)

13. COMPLIANCE TEST EXECUTION....Continued

SEAT BACK HEIGHT AND SURFACE AREA DIMENSIONS

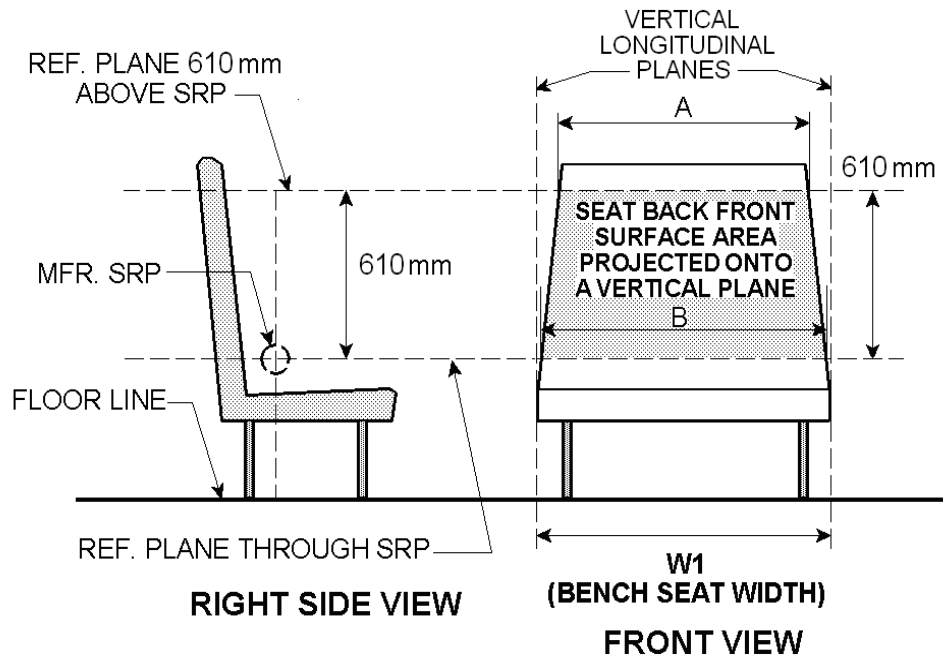

FIGURE 8

13.2 RESTRAINING BARRIER REQUIREMENTS

(Not Required For Class 2 Vehicles)

- A. Measure the distance in a horizontal plane from the SRP of the seat immediately behind the barrier to the aft side of the barrier. Record this measurement on Data Sheet 3. This measurement shall not exceed 610 mm, +0, -6 mm. (S5.2.1)
- B. For each restraining barrier, project the rear surface of the barrier onto a vertical transverse plane. Measure the projected surface area ($\pm 2\%$) that falls between the following planes, which are determined relative to the seat located immediately rearward of the barrier:
 - (1) A horizontal plane that passes through the SRP and a horizontal plane 610 mm above the SRP; and
 - (2) A vertical longitudinal plane that passes through the inboard-most point of the seat cushion and a vertical longitudinal plane that passes through the outboard-most point of the seat cushion.

13. COMPLIANCE TEST EXECUTION....Continued

Figure 9 shows the vital dimensions which must be recorded for a typical school bus restraining barrier. The area of the barrier as described above must be equal to or greater than 90 percent of the seat bench width of the seat immediately rearward of the barrier multiplied by 610 mm. Record these measurements and computations for each barrier measured on Data Sheet 3. (S5.1.2 and S5.2.2)

Measure the barrier width at 610 mm above the SRP of the seat immediately rearward of the barrier that falls between the planes described in (2), above. This dimension should be at least 75 percent of the maximum transverse width of the seat bench (W_1). Record these measurements and computations for each seat measured on Data Sheet 3. (S5.1.2 and S5.2.2)

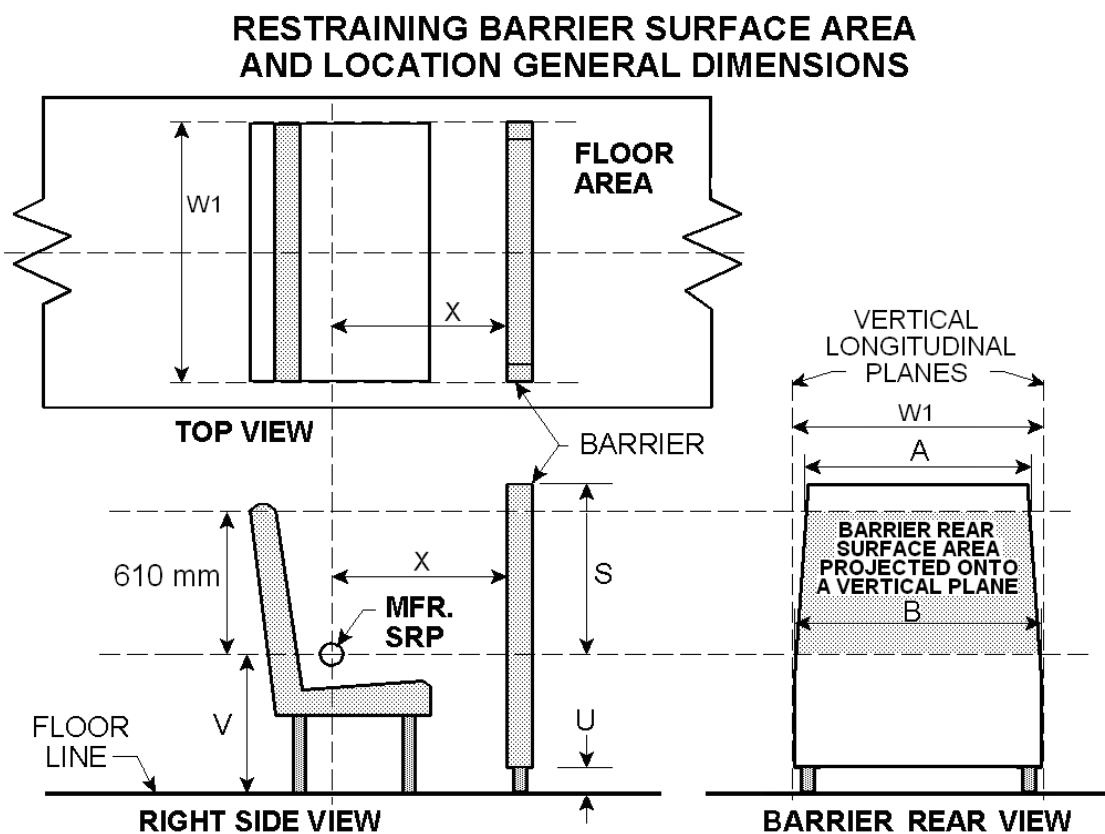

FIGURE 9

13.3 SEAT CUSHION LATCHING AND RETENTION

- A. For each school bus passenger seat design, select 2 school bus seats which have the same type of cushion. Complete Data Sheet 4 for each of the selected seats.
- B. Determine if the seat cushion is designed to be removable without tools or to flip up. If it is not, proceed directly to step H.

13. COMPLIANCE TEST EXECUTION....Continued

- C. Determine if the seat is equipped with a self-latching mechanism and record in Data Sheet 4. (S5.1.5 (a)) If the seat is not equipped with a self-latching mechanism, contact the COTR before proceeding with any further testing under section 13.3.
- D. Release the seat cushion latching mechanism and lift the cushion away from the seat frame.
- E. Gently place the seat cushion back onto its frame. If the self-latching mechanism does not activate under the seat cushion's own weight, do not push down on the seat or force the mechanism to activate.
- F. Place a mass of 22 kg, with a force distribution pad of 102 mm radius, at the geometric center of the top of the seat cushion as to produce a vertical downward force of 215.75 N, -0, +4.45. (S5.1.5 (a))
- G. Remove the load from the top of the seat cushion.
- H. Select an additional seat of the same design as that selected in step A. Remove the seat cushion by releasing the attachments. Weigh the cushion and record the value on Data Sheet 4.
- I. Position the upward load fixture at the center of the cushion underside. Use a force distribution pad of 102 mm radius between the load fixture and the cushion. If this is not possible, use a rectangular distribution pad of at least the same area which has dimensions such that force applied will be evenly distributed to the seat cushion.
- J. Install a calibrated load cell between the seat cushion and load applicator. Attach data recording equipment.
- K. Record all instrument settings, serial numbers, date, test operators, and zero and calibration checks. Apply an upward force equal to 5 times the weight of the cushion, +0, -2.22 N, to the center of the cushion underside. Apply the force in not less than 1 second or more than 5 seconds and maintain the force for 5 seconds, +1.0, -0. The force versus time shall be recorded and ultimately displayed on a graph. (S5.1.5 (b))
- L. The seat cushion shall not separate from the seat structure at any attachment point with application of this force. Record the post test zero and calibration check. (S5.1.5 (b))
- M. Record the results of the test on Data Sheet 4.

13. COMPLIANCE TEST EXECUTION....Continued

13.4 SEAT BACK FORCE/DEFLECTION TEST - FORWARD

- A. Select two passenger seats in the bus which have another seat located behind them. Remove the aft seat(s) and install the loading fixture in its place using the same floor and/or wall mounting holes, if possible.

A dual stroking device or loading fixture for conducting force/deflection testing is diagrammed in Figure 10. The diagram is only a suggested equipment setup, for it is NOT the intent of this laboratory test procedure to dictate the design of any test device other than the loading bars and head and knee forms specified in the standard. Testing laboratories are encouraged to use any type of equipment which will accomplish the objective and produce reliable data. All test equipment must be described in the laboratory test procedure which will be submitted for COTR approval prior to the initiation of compliance testing.

The loading fixture is equipped with a linear deflection measuring device which records the horizontal movement of the pivot point. A load measuring device(s) is installed to record load induced by the stroking device(s). Both instruments are connected to an x-y recorder which will display the force versus time and force versus deflection.

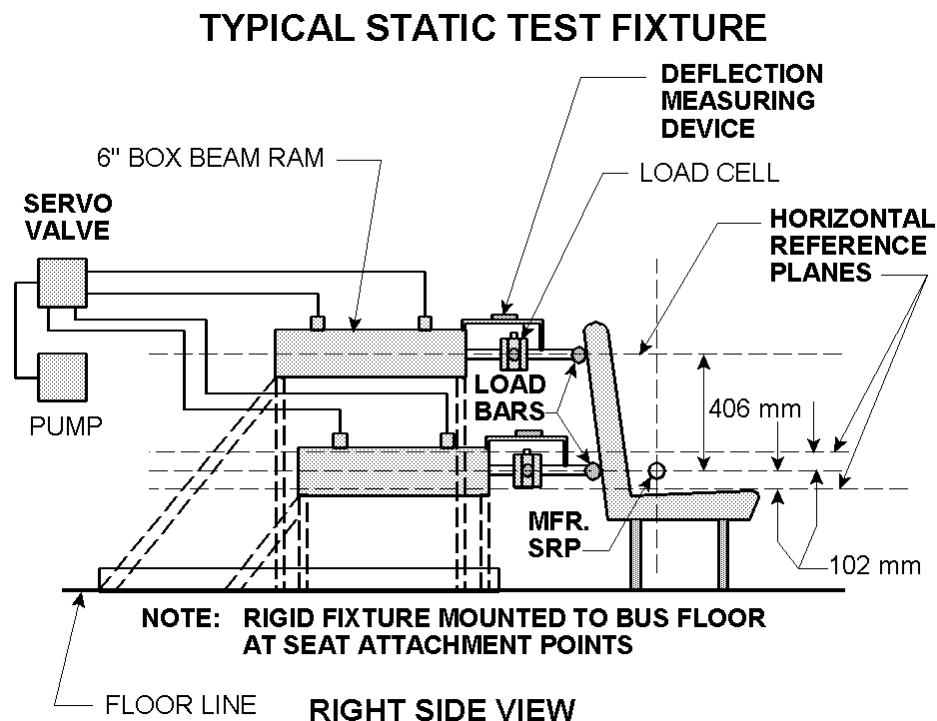

FIGURE 10

13. COMPLIANCE TEST EXECUTION....Continued

- B. Position the lower loading bar such that it is centered laterally behind the seatback and the pivot and stroking device are in a horizontal plane which is located in a vertical zone between 102 mm, +0, -6, above and 102 mm, +6, -0, below the SRP of the seat aft of the test seat. (See Figure 11 for lower load bar position.) (S5.1.3.1)

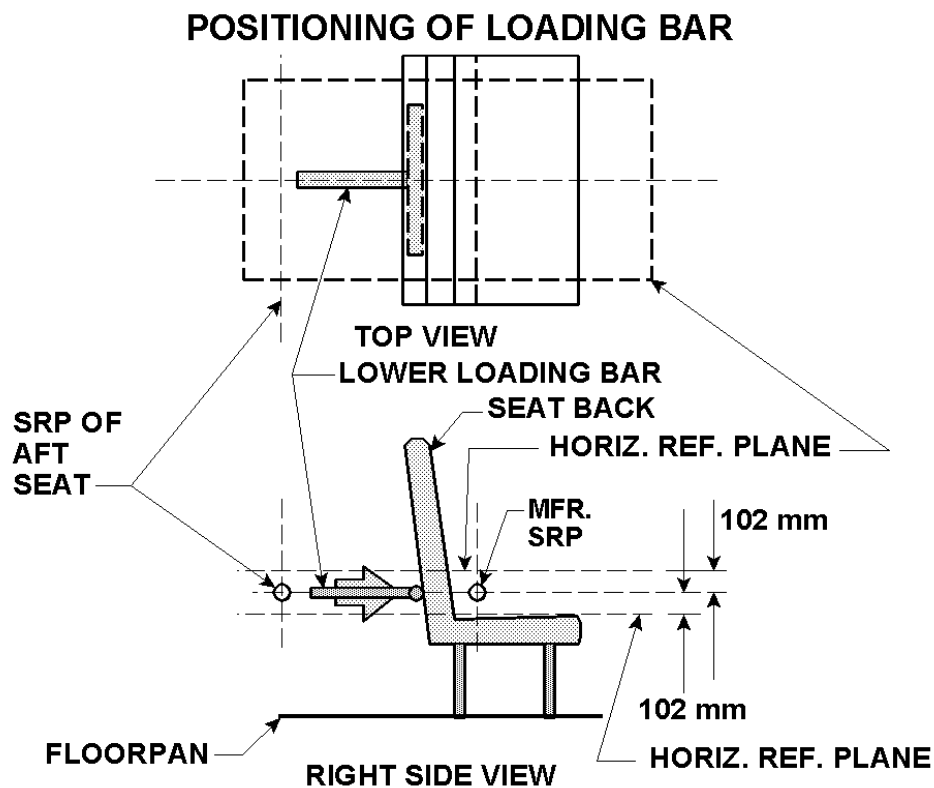

FIGURE 11

- C. Record all instrument settings, equipment serial numbers, test date, test operators, and zero and calibration checks. Apply a load through the pivot point equal to 3114W newtons, +44.5, -89. Reach this load in not less than 5 seconds and not more than 30 seconds. Hold the 3114W newtons, +44.5, -89, load for 1 to 3 seconds, after which, drop the load to 1557W newtons, +0, -44.5. Lock the stroking device in place at this time to maintain the displacement. (See Figure 12 for sample force/time trace at this point.) (S5.1.3.2)

Record the displacement on Data Sheet 5.

13. COMPLIANCE TEST EXECUTION....Continued

SEAT BACK FORCE/DEFLECTION CURVE LOWER LOADING BAR

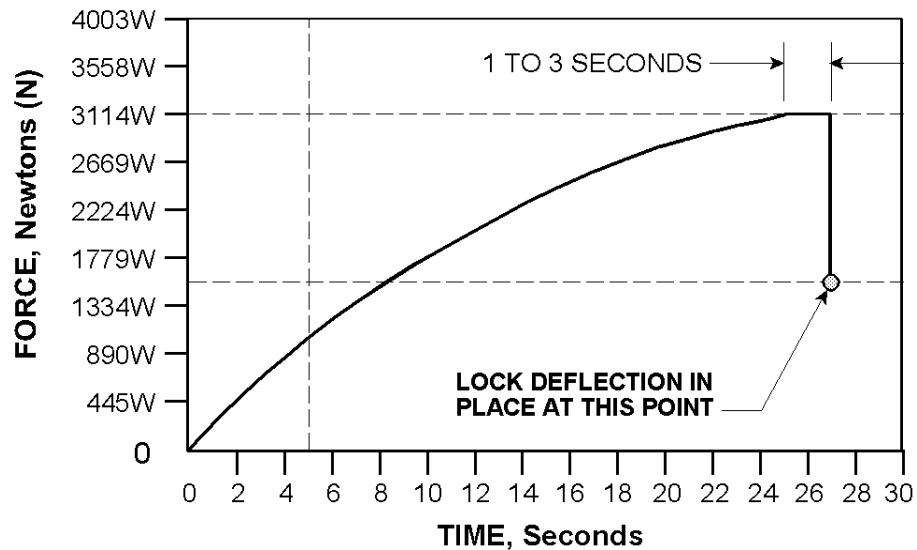

FIGURE 12

- D. Position the upper loading bar so that it is centered laterally along the seat back and the pivot attachment point and stroking device are in a horizontal plane 406 mm above ± 6 mm, the SRP. Apply a preload of 44.48 N, +4, -0, through the upper loading bar. Lock the loading bar in position. (S5.1.3.3)
- E. Determine if an additional 356 mm of seat back horizontal displacement (measured at the upper loading bar) will bring the seat back within 102 mm of any part of another school bus seat or restraining barrier. See Figure 13 for suggested determination.
- F. The contractor's test engineer shall pick an amount of time between 6 and 29 seconds in which the seat back will be deflected. Using this time limit the test engineer will determine a movement rate (mm per second) for the upper loading bar. (S5.1.3.4)
- G. Deflect the seat back at the rate determined in step F until the deflection of 356 mm is reached. Carefully inspect the seat attachment points and component joints for an indication of any separation that may have occurred. (S5.1.3)

13. COMPLIANCE TEST EXECUTION....Continued

QUICK DETERMINING DEVICE

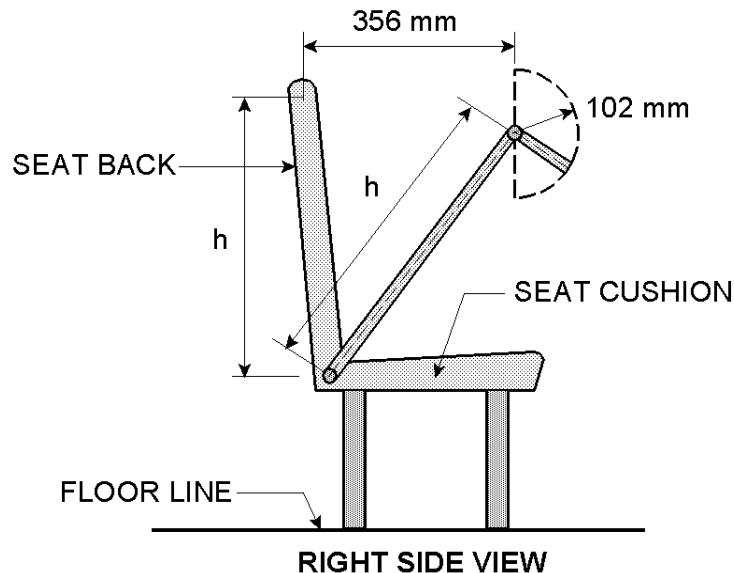

FIGURE 13

- H. When the maximum deflection described above is reached, stop deflecting the seat back, maintain the load for 5 to 10 seconds and then immediately back the loading bar away from the seat back completing the unloading (reaching zero load) between 5 and 30 seconds. Record the post test zero and calibration check. Inspect attachment points and component joints for separations. (S5.1.3.4)
- I. The force vs. deflection event of loading and unloading the seat back will be recorded on an x-y plot. The deflection vs. time history of the event will also be recorded on an x-y plot. Both plots will be included in the test report. The data may be digitally recorded but must be shown as x-y plots in the test reports.
- J. Superimpose the boundaries shown in Figure 14, Seat Back and Restraining Barrier Force/Deflection Zone (Forward Test) on the force vs. deflection plot for the upper loading bar. (S5.1.3)

13. COMPLIANCE TEST EXECUTION....Continued

**SEAT BACK AND RESTRAINING BARRIER
FORCE DEFLECTION ZONE (FORWARD TEST)**

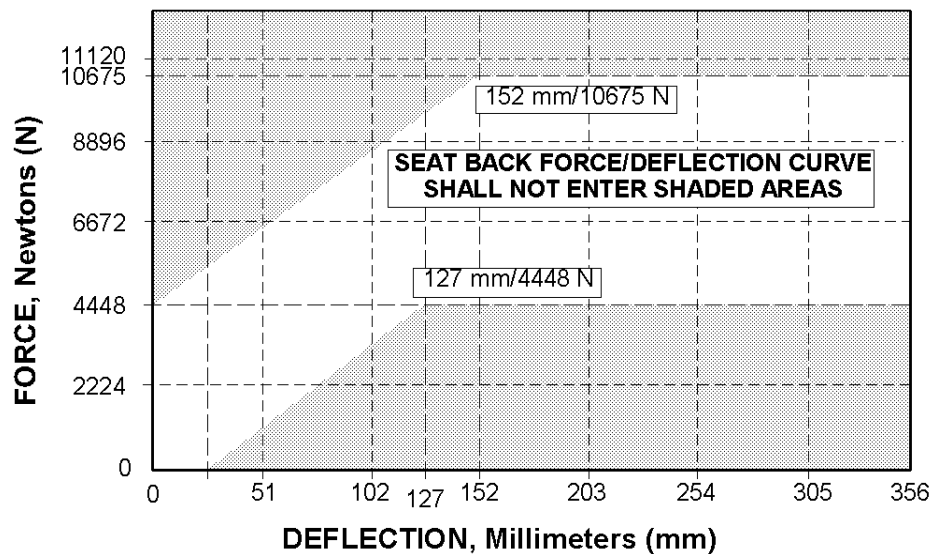

FIGURE 14

- K. Measure the area within the force vs. deflection curve, using a planimeter or an equivalent tool.
- L. Record the results of the seat back force/deflection test-forward, on Data Sheet 5.

13.5 BARRIER PERFORMANCE – FORWARD (Not required for Class 2 buses)

- A. Project the SRP of the seat aft of the barrier forward and mark the vertical height on the barrier.
- B. Remove the seat(s) aft of the restraining barrier and install the loading fixture in its place using the same wall and/or floor mounting holes, if possible. If the barrier is behind the driver's seat, place the driver's seat in the mid-position of horizontal and vertical travel. Document the effect of the testing on the driver's seat.
- C. Position the lower loading bar so that it is centered laterally behind the barrier and the pivot and stroking device are in a horizontal plane located vertically somewhere between 102 mm above, +0, -6.3, and 102 mm below, +6.3, -0, the SRP. (S5.1.3.1)

13. COMPLIANCE TEST EXECUTION....Continued

- D. Record all instrument settings, equipment serial numbers, test date, test operators, and zero and calibration checks. Calculate W using the bench seat width measurement of the seat aft of the restraining barrier. Apply a load through the pivot point equal to $3114W$ newtons, $+0, -44.5$. Reach this load in not less than 5 seconds and not more than 30 seconds. Hold the $3114W$ newton load, $+0, -44.5$, for at least 1 to 3 seconds, after which, drop the load to $1557W$ newtons, $+0, -44.5$. Lock the stroking mechanism in place at this time to maintain the displacement. (See Figure 15 for sample force vs. time plot at this point.)

**SEAT BACK FORCE/DEFLECTION CURVE
LOWER LOADING BAR**

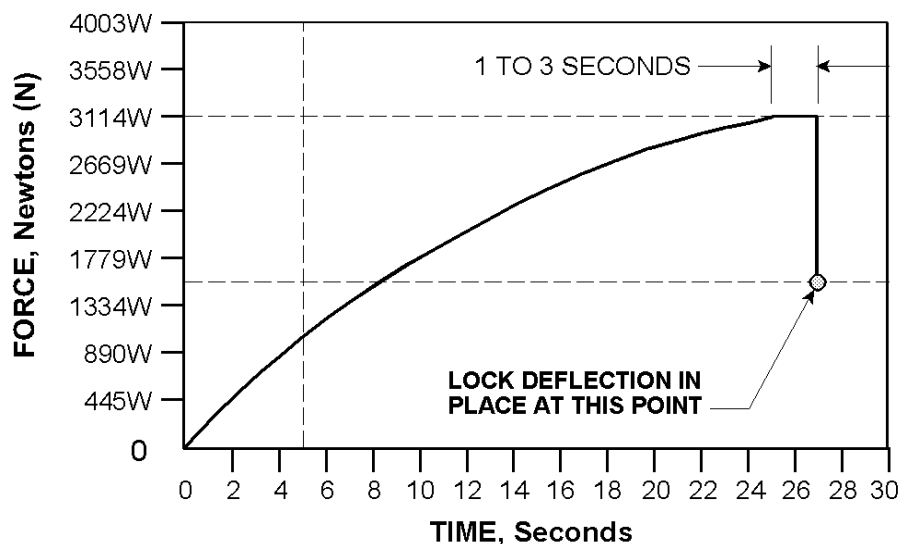

FIGURE 15

- E. Center the upper loading bar laterally along the barrier so that the pivot and stroking bar are in a horizontal plane 406 mm above the SRP, ± 6.5 . Apply a preload of 44.5 newtons, $+44.5, -0$. Lock the loading bar in position. (S5.1.3.3)
- F. Determine if the 356 mm of additional deflection, measured through the upper loading bar, will cause the restraining barrier to interfere with the normal operation of the door.
- G. Select an amount of time between 6 and 29 seconds in which the barrier will be deflected. The test engineer will determine a movement rate (mm per second) for the loading bar. (S5.1.3)

13. COMPLIANCE TEST EXECUTION....Continued

- H. Deflect the barrier at the rate determined in step G until the target deflection of 356 mm is reached. Carefully, inspect barrier attachment points and barrier components for an indication of any separation that may have occurred. (S5.2.3)
- I. When the maximum deflection of 356 mm is reached stop deflecting the barrier, maintain the load for 5 to 10 seconds and then immediately back the loading bar away from the barrier completely unloading the barrier in not less than 5 seconds and not more than 30 seconds. Record the post test zero and calibration checks. (S5.1.3.4)
- J. The force vs. deflection event, including unloading, and the deflection vs. time history will both be recorded on x-y plots which will be included in the test report. The data may be digitally recorded but must be shown as x-y plots in the test report.
- K. Superimpose the boundaries shown in Figure 16 on the force vs. deflection plot for the upper loading bar. (S5.1.3)

SEAT BACK AND RESTRAINING BARRIER FORCE DEFLECTION ZONE (FORWARD TEST)

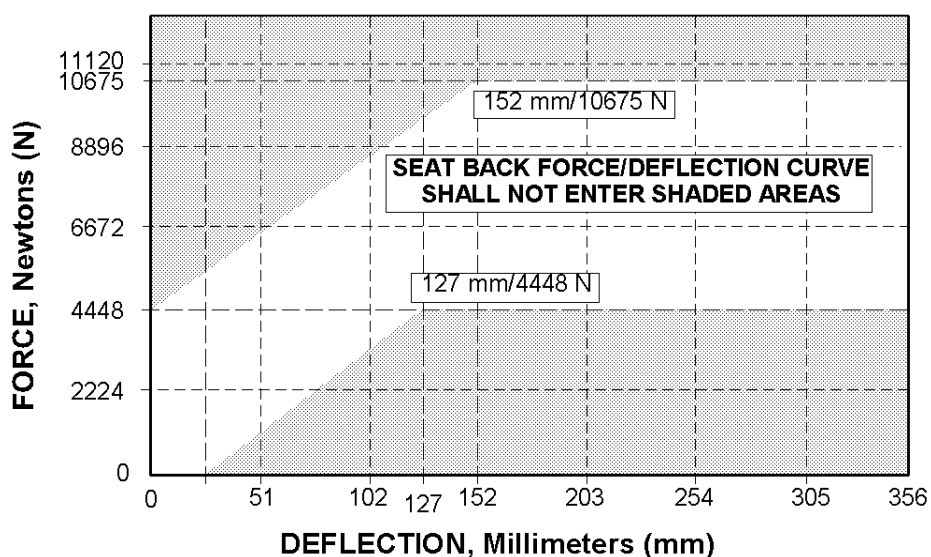

FIGURE 16

- L. Using a planimeter or an equivalent tool, measure the area bounded by the force/deflection curve.
- M. Record results of restraining barrier force/deflection test on Data Sheet 6.

13. COMPLIANCE TEST EXECUTION....Continued

13.6 SEAT BACK FORCE/DEFLECTION TEST - REARWARD

- A. Select two passenger seats which have another seat located to the front and rear of them. Remove the forward seat(s) and install the loading fixture in that space using the same wall and/or floor mounting holes, if possible.
- B. Center the loading bar laterally (plus or minus 6.3 mm) on the front of the seat back with the stroking bar in a horizontal plane 343 mm, +6.3, -0, above the SRP and parallel with the plane of the floor. Move the loading bar rearward to preload the seat back to 222 newtons, +44.5, -0. (S5.1.4.1)
- C. Determine if 254 mm of seat back horizontal displacement, measured at the loading bar, will bring the seat back to within 102 mm of any part of another seat. Pay particular attention to the distance between the seat back and the seat cushion of the seat behind the test specimen. (See Figure 17)

QUICK DETERMINING DEVICE

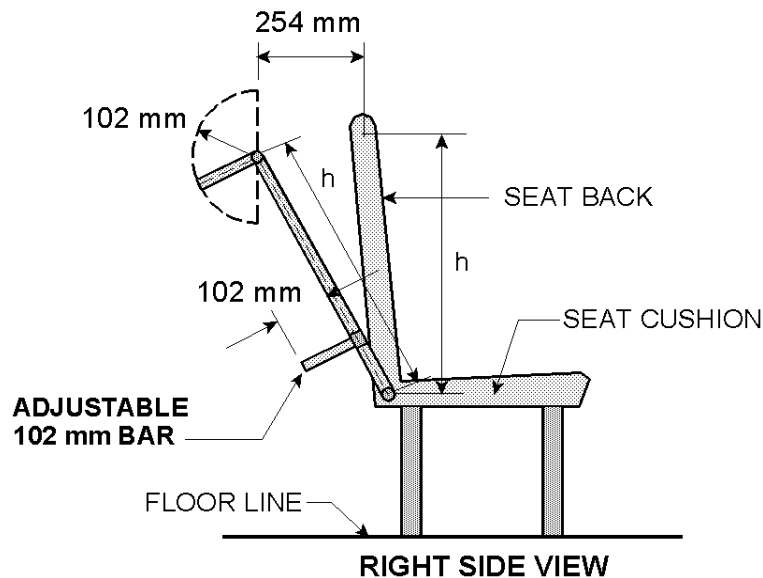

FIGURE 17

- D. The contractor's test engineer shall pick an amount of time between 6 and 29 seconds in which the seat back shall be deflected rearward. Using this quantity of time, the test engineer shall calculate a movement rate (mm per second) for the loading bar.

13. COMPLIANCE TEST EXECUTION....Continued

- E. Record all instrument settings, equipment serial numbers, test date, test operators, and zero and calibration checks. Deflect the seat back at the rate determined in step D until the deflection of 254 mm has been reached. Carefully inspect the seat attachment points and component joints for an indication of any separation that may have occurred. Measure and record the deflection of the seat back on Data Sheet 7.
- F. When the seat loading is stopped, maintain the load for 5 to 10 seconds and then immediately back the loading bar away so that the seat back is completely unloaded in no less than 5 seconds and no more than 30 seconds. Record the post test zero and calibration checks. Inspect attachment points and component joints for separations. (S5.1.4.2)
- G. The force vs. deflection event, including unloading, and the deflection vs. time history will both be recorded on x-y plots which will be included in the test report. The data may be digitally recorded but must be shown as x-y plots in the test report.
- H. Superimpose the boundaries shown in Figure 18 on the force vs. deflection in plot.

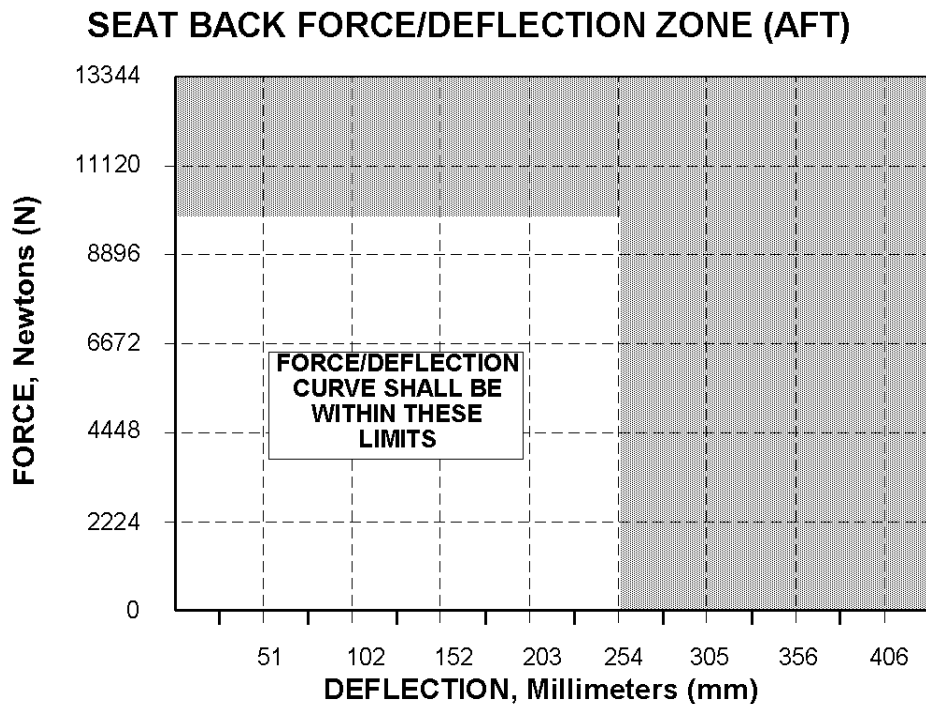

FIGURE 18

13. COMPLIANCE TEST EXECUTION....Continued

- I. Using a planimeter or an equivalent tool, measure the area within the force vs. deflection curve.
- J. Record the results of seat back force/deflection test-aft on Data Sheet 7.

13.7 HEAD FORM IMPACT ZONE TESTS

- A. Using the SRP of the seat aft of the test seat or barrier as the reference point, mark the areas of the seat back, driver's seat, walls, barriers, stanchions, or other locations which fall into the head protection zone described below and shown in Figure 19.
 - (1) Horizontal planes, 305 mm, +6.3, -0, and 1016 mm, +6.3, -0, above the SRP. (S5.3.1.1(a))
 - (2) A vertical longitudinal plane tangent to the inboard (aisle side) edge of the seat, +0, -6.3. (S5.3.1.1(b))
 - (3) A vertical longitudinal plane 82 mm, +6.3, -0, inboard of the outboard edge of the seat. (S5.3.1.1(c))
 - (4) Vertical transverse planes through the SRP, +6.3, -0, and 762 mm, +0, -6.3, forward of the SRP, except any surface on the front of a seat back or restraining barrier 76 mm or more below the top of the seat back or restraining barrier. (S5.3.1.1(d) & S4)

SEAT BACK CONTACTABLE SURFACE LYING WITHIN HEAD PROTECTION ZONE

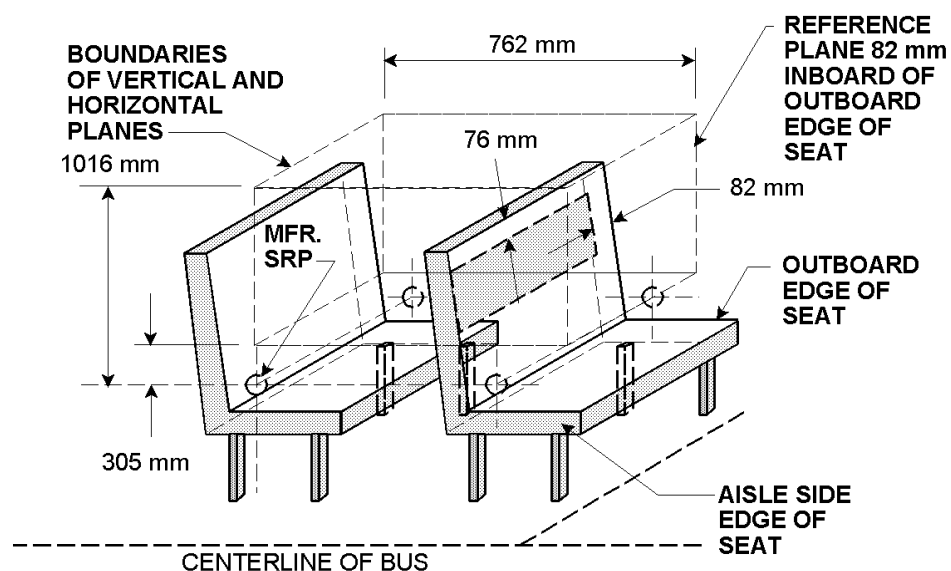
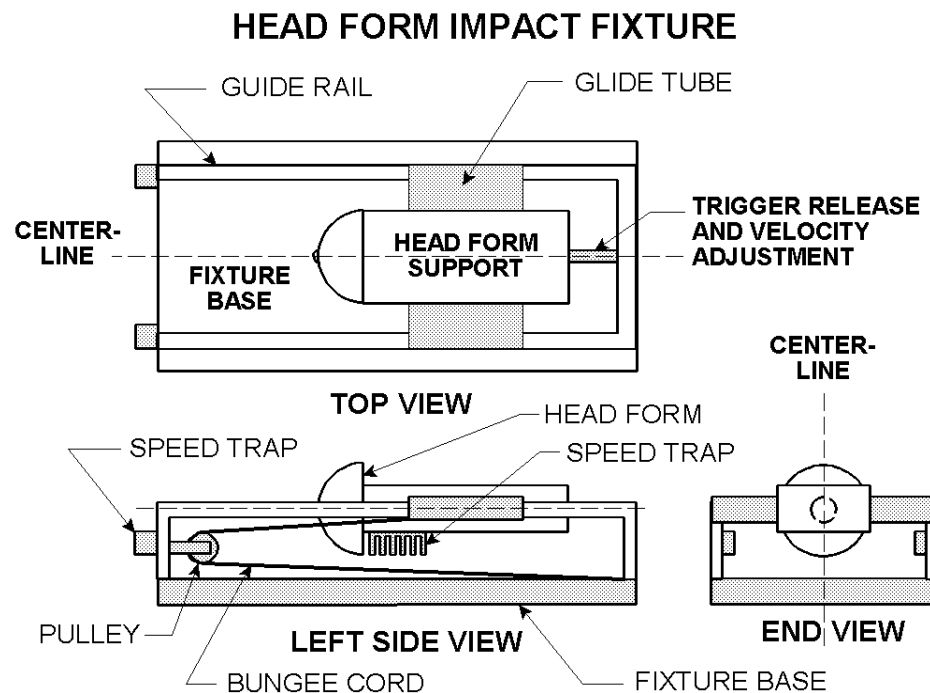

FIGURE 19

13. COMPLIANCE TEST EXECUTION....Continued

- B. Determine all surfaces that are located within the head impact zones. Any surface in the impact zone that is not a seat back, sidewall, window or door structure must be reported to the COTR. The COTR will decide whether any non-seat back surfaces shall be tested for compliance with head impact requirements. (S5.3.1.1)
- C. Remove the seat(s) aft of the test seat or barrier and install a test fixture containing the head form in the same wall and/or floor mounting holes, if possible.
- D. A diagram of one type of head form stroking device is shown in Figure 20. The contracted laboratory may use any type of stroking device which will accomplish the objective.



- E. Select 7 impact locations and impact angles within the head protection zone. Stripping a previously tested seat to examine the padding, structure and metal frame location may be helpful in selecting the most suitable impact points. Record the x-y description of each impact location with respect to a common reference point. Record the impact angle of each impact location with respect to a defined reference plane. No two locations in the same plane may be within a 102 mm radius of each other. Describe in writing in the test report the common reference point location and the impact angle reference plane.
- F. Coat the head form surface with a lipstick, Drum Beat Red, made by L'Oreal which will adhere to the seat cover fabric when the head form contacts it. The lipstick must be applied so that splatter is not recorded as contacted area.

13. COMPLIANCE TEST EXECUTION....Continued

- G. Strike the 7 locations with the head form traveling at a constant speed of 1.52 meters per second (mps), $+0.076$, -0 . Record the velocity from the speed trap mounted on the stroking device on Data Sheet 8. Digitally record the acceleration data from the time the head form begins moving.
- H. After each impact blot the struck area with Keuffel & Esser No. 460862 graph paper to record the contact print of the impact. Collect as much of the transfer medium on the paper as possible.
- I. Draw straight line connections around complete contact prints. The lines will connect the outer most extremities of the contact prints as shown in Figure 21.

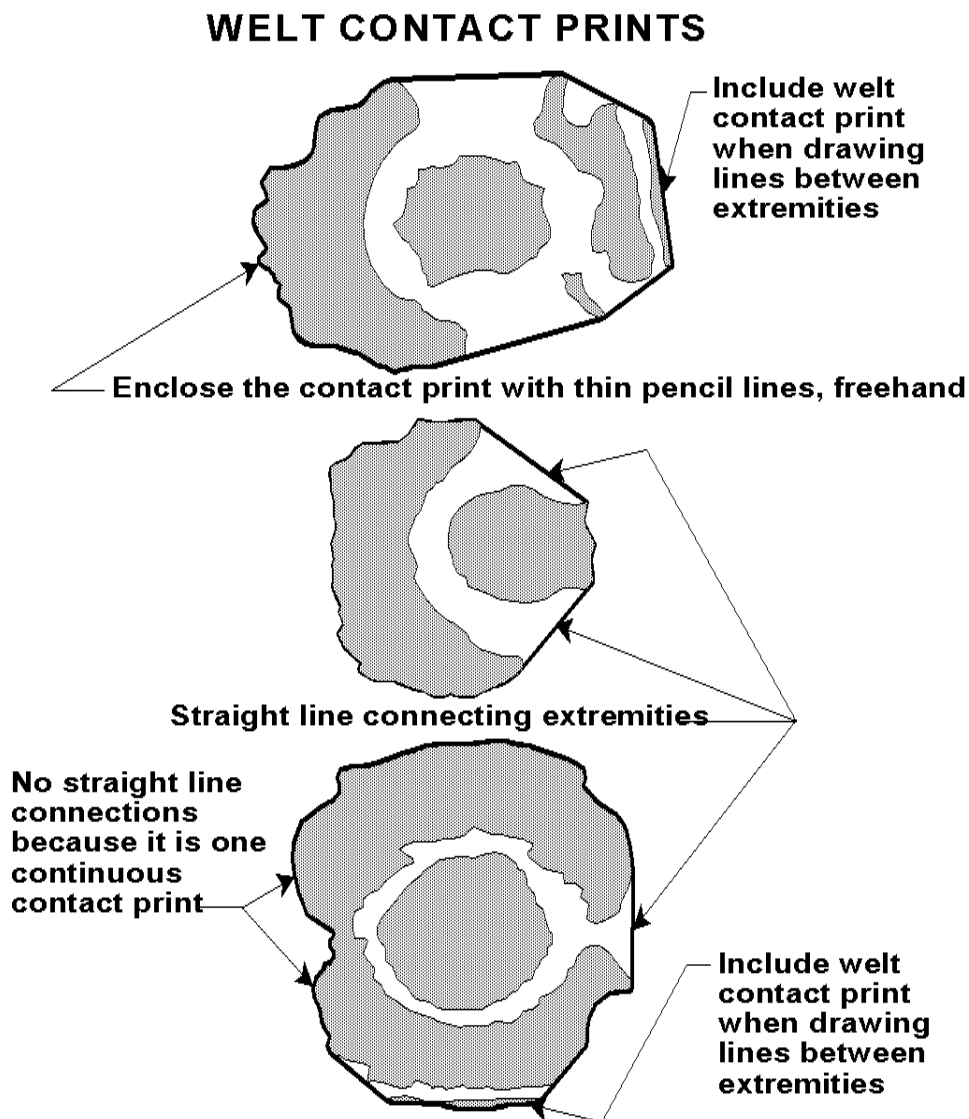

FIGURE 21

13. COMPLIANCE TEST EXECUTION....Continued

- J. Measure the encompassed area with a planimeter or an equivalent tool and record the area on Data Sheet 8.
- K. Select an additional 7 locations and impact angles in the head protection zone which are suitable with respect to the impact requirements. Stripping a previously tested seat to examine the padding, structure and metal locations may be helpful in selecting the impact locations. Record the x-y description of each impact location with respect to the same reference point used in step E. Record the impact angle of each impact location with respect to the same reference plane used in step E on Data Sheet 9. No two locations in the same plane may be within a 102 mm radius of each other, including previous testing. If necessary use another seat of the same design.
- L. Impact 7 locations with the instrumented head form at a constant speed (zero acceleration) of 6.69 mps, +0, -0.076, at the instant of impact. Record the velocity from the speed trap mounted on the stroking device on Data Sheet 9. Digitally record the acceleration data from the time the head form begins moving.
- M. Process the acceleration vs. time data recorded from the head form accelerometer by the following procedures:

Determine the maximum value which can be calculated from the following expression by repetitive calculation using all possible t_1 and t_2 values on the a-t curve

$$\left[\frac{1}{(t_1 - t_2)} \int_{t_1}^{t_2} a \, dt \right]^{2.5} (t_2 - t_1)$$

where "a" is the axial acceleration expressed as a multiple of "g" (acceleration due to gravity = 9.79 meters per second per second, mpsps, mps²). The value should not exceed 1,000. The algorithm for this calculation will be supplied by the COTR. (S5.3.1.2)

- N. (1) Determine the force vs. time plot using the acceleration vs. time plot.
- (2) Mark the point at which force reached 667 newtons (N). Integrate the area under the curve to that point, and then using the calculated quantity of the change in momentum, determine the energy necessary to deflect the impacted material to that point. See equations below.

$$\int_{t_0}^{t_f} F dt = m (v_F - v_0)$$

13. COMPLIANCE TEST EXECUTION....Continued

Where:

F = force on head form at any point in time during impact

m = mass of head form = $(51 \text{ N}/9.79 \text{ mps}^2) = 5.21 \text{ Kg}$

a = acceleration at any point in time during impact

v_0 = initial velocity = 6.69 mps

v_F = final velocity where F = 667 N

t_0 = time at impact

t_F = time during impact where F = 667 N

Area under Force-Time curve =

Solve this expression for v_F

$$\text{Energy} = \frac{1}{2} m (v_F^2 - v_0^2)$$

Solve this expression for energy necessary to deflect impacted material where F = 667 newtons

This energy must be greater than 4,521 mm-N. (S5.3.1.3)

In the test report, show the calculations for each impact.

- O. Record results of head form impact test requirements on Data Sheet 9.
- P. Determine the velocity versus time plot using the acceleration versus time data. Verify velocity is constant prior to impact for both the area and impact/force distribution requirements. Verify the impact velocity from the plot within 0.608 mps of the velocity as measured by the speed trap.
- Q. Acceleration versus time plots, velocity versus time plots, and force versus time plots derived from acceleration data shall be included in the test reports.

13.8 KNEE FORM IMPACT ZONE TESTS

- A. Layout the leg protection zone on the test seat back or restraining barrier such that it encompasses that portion of the test seat back or restraining barrier bound by horizontal planes 305 mm, +0, -6.3, above and 102 mm, +0, -6.3, below the SRP of the seat immediately aft of the test specimen as shown in Figure 22. (S5.3.2.1)
- B. Select 8 impact locations and impact angles in this zone which are suitable with respect to the impact requirements. Stripping a previously tested seat to examine the padding, structure and metal locations may be helpful in selecting the impact points. Record the x-y description of each location with respect to a common reference point. Record the impact angle of each impact location with respect to a defined reference plane. Describe the common reference point location and impact angle reference plane in the test report.

13. COMPLIANCE TEST EXECUTION....Continued

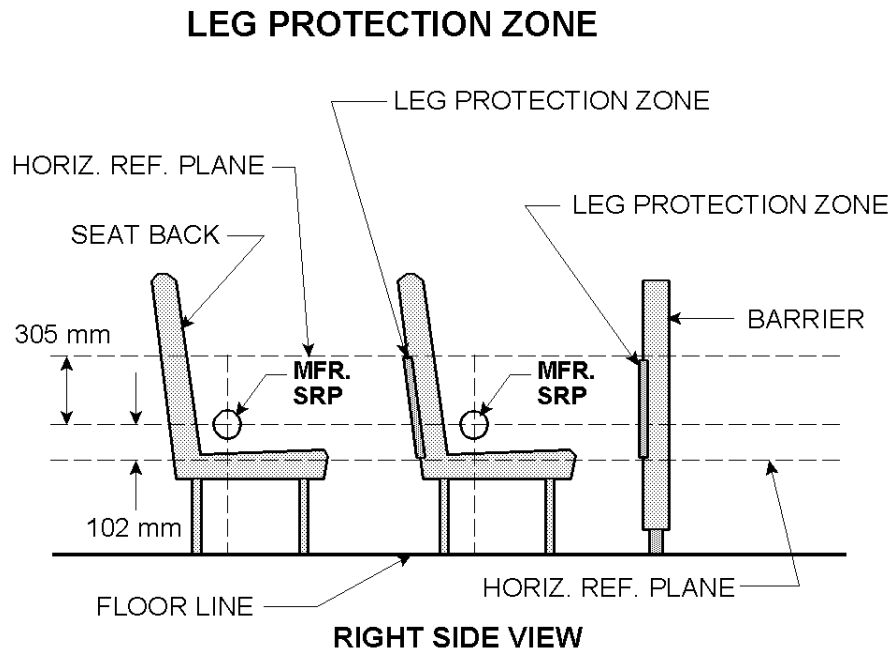

FIGURE 22

- C. Remove the seat(s) aft of the test seat or restraining barrier and install the impact fixture containing the instrumented knee form.
- D. Coat the knee form with the same substance used to define contact area for the head form test (lipstick made by Loreal — Drum Beat Red) insuring that "splatter" will be negligible at impact.
- E. Impact 4 of the selected locations at a constant speed (zero acceleration) of 4.86 mps, +0.076, -0, to check the contact area and 4 at 4.86 mps, +0, -0.076, to check the resistive force. Record the impact velocity from the speed trap on Data Sheet 10. Digitally record the acceleration data from the time the knee form begins moving.
- F. Determine the velocity versus time plot using the acceleration versus time data. Verify the velocity is constant prior to impact for both the area and impact/force distribution requirements. Verify the impact velocity from the plot within 0.608 mps of the velocity as measured by the speed trap.
- G. Record and measure contact area using the procedure described in the head form impact test. (13.7 H through 13.7 J)
- H. Produce a force vs. time plot from the recorded acceleration vs. time curve. Determine the peak resistive force.

13. COMPLIANCE TEST EXECUTION....Continued

- I. Record the results of the knee form impact test on Data Sheet 10.
- J. Acceleration versus time plots, velocity versus time plots, and force versus time plots derived from acceleration data shall be included in the test reports.

13.9 SEAT BELT ASSEMBLY ANCHORAGES (FMVSS 210)

Applicable to Class 2 school buses only.

See Appendix 1

13.10 OCCUPANT CRASH PROTECTION IN PASSENGER CARS AND, MULTIPURPOSE PASSENGER VEHICLES, TRUCKS AND BUSES (FMVSS 208)

Applicable to Class 2 school buses only.

See Appendix 2

13.11 WHEELCHAIR SECUREMENT ANCHORAGES AND DEVICES WHEELCHAIR OCCUPANT RESTRAINT ANCHORAGES AND RESTRAINTS

Applicable to school buses with wheelchair location only.

See Appendix 3

14. POST TEST REQUIREMENTS

- A. Verify all instrumentation, data sheets and photographs are complete
- B. Protect the school bus from further damage.
- C. Move the test vehicle to a secure area,
- D. Place all original records in a secure and organized file awaiting test data disposition.

15. REPORTS

15.1 MONTHLY STATUS REPORTS

The contractor shall submit a monthly Test Status Report and a Vehicle Status Report to the COTR. The Vehicle Status Report shall be submitted until all vehicles or items of equipment are disposed of. Samples of the required Monthly Status Reports are contained in the Report Forms section.

15.2 APPARENT NONCOMPLIANCE

Any indication of a test failure shall be communicated by telephone to the COTR within 24 hours with written notification mailed within 48 hours (Saturdays and Sundays excluded). A Notice of Test Failure (see report forms section) with a copy of the particular compliance test data sheet(s) and preliminary data plot(s) shall be included. In the event of a test failure, a post test calibration check of some critically sensitive test equipment and instrumentation is required for verification of accuracy. The calibration shall be performed without additional costs to the OVSC.

15.3 FINAL TEST REPORTS

15.3.1 COPIES

In the case of a test failure, 7 copies (2 color hard copies and 5 CDs) of the Final Test Report shall be submitted to the COTR for acceptance within three weeks of test completion. The Final Test Report format to be used by all contractors can be found in the "Report Section".

Where there has been no indication of a test failure, 3 copies (2 color hard copies and 3 CDs) of each Final Test Report shall be submitted to the COTR within three weeks of test completion. Payment of contractor's invoices for completed compliance tests may be withheld until the Final Test Report is accepted by the COTR. Do NOT submit invoices before the COTR is provided copies of the Final Test Report.

Contractors are required to submit the first Final Test Report in draft form within two weeks after the compliance test is conducted. The contractor and the COTR will then be able to discuss the details of both test conduct and report content early in the compliance test program.

Contractors are required to PROOF READ all Final Test Reports before submittal to the COTR. The OVSC will not act as a report quality control office for contractors. Reports containing a significant number of errors will be returned to the contractor for correction, and a "hold" will be placed on invoice payment for the particular test.

15. REPORTS....Continued

15.3.2 REQUIREMENTS

The Final Test Report, associated documentation (including photographs) are relied upon as the chronicle of the compliance test. The Final Test Report will be released to the public domain after review and acceptance by the COTR. For these reasons, each final report must be a complete document capable of standing by itself.

The contractor should use DETAILED descriptions of all compliance test events. Any events that are not directly associated with the standard but are of technical interest should also be included. The contractor should include as much DETAIL as possible in the report.

Instructions for the preparation of the first three pages of the final test report are provided below for the purpose of standardization.

15.3.3 FIRST THREE PAGES

A. FRONT COVER

A heavy paperback cover (or transparency) shall be provided for the protection of the final report. The information required on the cover is as follows:

(1) Final Report Number such as 222-ABC-XX-001 where –

222 is the FMVSS tested
 ABC are the initials for the laboratory
 XX is the last two numbers of the Fiscal Year of the test program
 001 is the Group Number (001 for the 1st test)

(2) Final Report Title and Subtitle such as

COMPLIANCE TESTING FOR FMVSS 222
 School Bus Seating and Crash Protection
 * * * * *

World Motors Corporation
 20XX XYZ School Bus
 NHTSA No. CX0901

(3) Contractor's Name and Address such as

COMPLIANCE TESTING LABORATORIES, INC.
 4335 West Dearborn Street
 Detroit, Michigan 48090

NOTE: DOT SYMBOL WILL BE PLACED BETWEEN ITEMS (3) AND (4)

15. REPORTS....Continued

- (4) Date of Final Report completion
- (5) The words "FINAL REPORT"
- (6) The sponsoring agency's name and address as follows

U. S. DEPARTMENT OF TRANSPORTATION
National Highway Traffic Safety Administration
Enforcement
Office of Vehicle Safety Compliance
Mail Code: NVS-220
1200 New Jersey Ave., SE
Washington, DC 20590

B. FIRST PAGE AFTER COVER PAGE

When a contract test laboratory is reporting, a disclaimer statement and an acceptance signature block for the COTR shall be provided as follows:

This publication is distributed by the National Highway Traffic Safety Administration in the interest of information exchange. Opinions, findings and conclusions expressed in this publication are those of the author(s) and not necessarily those of the Department of Transportation or the National Highway Traffic Safety Administration. The United States Government assumes no liability for its contents or use thereof.

If trade or manufacturers' names or products are mentioned, it is only because they are considered essential to the object of the publication and should not be construed as an endorsement.

Prepared By: _____

Approved By: _____ *

Approval Date: _____ *

FINAL REPORT ACCEPTANCE BY OVSC: *

Accepted By: _____

Acceptance Date: _____

* These lines not required when OVSC staff writes the Test Report

15. REPORTS....Continued**C. SECOND PAGE AFTER FRONT COVER**

A completed Technical Report Documentation Page (Form DOT F1700.7) shall be completed for those items that are applicable with the other spaces left blank. Sample data for the applicable block numbers of the title page follows.

Block 1 — REPORT NUMBER

222-ABC-XX-001

Block 2 — GOVERNMENT ACCESSION NUMBER

Leave blank

Block 3 — RECIPIENT'S CATALOG NUMBER

Leave blank

Block 4 — TITLE AND SUBTITLE

Final Report of FMVSS 222 Compliance Testing of 20XX World XYZ School Bus,
NHTSA No. CX0901

Block 5 — REPORT DATE

Month Day, 20XX

Block 6 — PERFORMING ORGANIZATION CODE

ABC

Block 7 — AUTHOR(S)

John Smith, Project Manager
Bill Doe, Project Engineer

Block 8 — PERFORMING ORGANIZATION REPORT NUMBER

ABC-DOT-XXX-001

15. REPORTS....Continued

Block 9 — PERFORMING ORGANIZATION NAME AND ADDRESS

ABC Laboratories
405 Main Street
Detroit, MI 48070

Block 10 — WORK UNIT NUMBER

Leave blank

Block 11 — CONTRACT OR GRANT NUMBER

DTNH22-XX-D-12345

Block 12 — SPONSORING AGENCY NAME AND ADDRESS

U.S. Department of Transportation
National Highway Traffic Safety Administration
Enforcement
Office of Vehicle Safety Compliance
Mail Code: NVS-220
1200 New Jersey Ave., SE
Washington, DC 20590

Block 13 — TYPE OF REPORT AND PERIOD COVERED

Final Test Report
Month Day to Month Day, 20XX

Block 14 — SPONSORING AGENCY CODE

NVS-220

Block 15 — SUPPLEMENTARY NOTES

Leave blank

15. REPORTS....Continued

Block 16 — ABSTRACT

Compliance tests were conducted on the subject 20XX World XYZ School Bus in accordance with the specifications of the Office of Vehicle Safety Compliance Test Procedure No. TP-222-XX for the determination of FMVSS 222 compliance. Test failures identified were as follows:

None

NOTE: Above wording must be shown with appropriate changes made for a particular compliance test. Any questions should be resolved with the COTR.

Block 17 — KEY WORDS

Compliance Testing
Safety Engineering
FMVSS 222

Block 18 — DISTRIBUTION STATEMENT

National Highway Traffic Safety Administration
Technical Information Services Division, NPO-411
1200 New Jersey Avenue SE (Room E12-100)
Washington DC 20590

e-mail: tis@nhtsa.dot.gov
FAX: 202-493-2833

Block 19 — SECURITY CLASSIFICATION OF REPORT

Unclassified

Block 20 — SECURITY CLASSIFICATION OF PAGE

Unclassified

Block 21 — NUMBER OF PAGES

Add appropriate number

Block 22 — PRICE

Leave blank

15. REPORTS....Continued

15.3.4 TABLE OF CONTENTS

Final test report Table of Contents shall include the following:

Section 1 — Purpose of Compliance Test

Section 2 — Compliance Test Data Summary

Section 3 — Compliance Test Data

Section 4 — Noncompliance Data (if applicable)

Section 5 — Photographs

16. DATA SHEETS

GENERAL TEST DATA SHEET

SCHOOL BUS IDENTIFICATION —

MODEL YEAR/MFR./MAKE/MODEL: _____

WHEELBASE: _____ mm; PASSENGER CAPACITY: _____

NHTSA NO.: _____ ; VIN: _____

CONVENTIONAL OR FORWARD CONTROL: _____

GVWR (From Certification Label): FRONT - _____ kg

REAR - _____ kg

TEST CONDITIONS —

DATE(S) OF TEST: _____

TIME OF TEST: _____ ; AMBIENT TEMPERATURE: _____ °C

REQUIRED TEMP. RANGE = 0°C to 32.2°C

SEAT IDENTIFICATION —

SEAT MANUFACTURER: _____

MODEL NAME & NUMBER: _____

DESCRIPTION OF SEATS:

EXAMPLE: Backs and cushion are ABC foam construction with 13 mm plywood boards, 995 gram vinyl upholstery. Tubular steel frames of 25.4 mm diameter are wall mounted.

16. DATA SHEETS....Continued

DATA SHEET 1
SEAT TO SEAT/BARRIER SPACING
SCHOOL BUS NHTSA NO.: _____

SEAT NUMBER	MEASUREMENT OF SPACING FROM SRP FORWARD TO SEAT/BARRIER	REQMT. 610 mm (CLASS I BUSES ONLY)	
		YES - PASS	NO - FAIL
1			
2			
3			
4			
5			
6			
7			
8			

REMARKS:

RECORDED BY: _____ ; DATE: _____

APPROVED BY: _____

16. DATA SHEETS....Continued

DATA SHEET 2
SEAT BACK HEIGHT & FRONT SURFACE AREA TEST
SCHOOL BUS NHTSA NO.: _____

SEAT NUMBER: _____

1. Maximum vertical height of the seat back above the SRP = _____ mm
2. Is item 1 greater than or equal to 610 mm? (S5.1.2)
_____ Yes – Pass _____ NO - FAIL
3. Maximum transverse width of the seat cushion (W1) = _____ mm
4. Calculate the following: $0.75 \times W1 =$ _____ mm
5. Calculate the following: $0.90 \times W1 \times 610 \text{ mm} =$ _____ mm²
6. Project the front surface of the seat back onto a vertical transverse plane. Measure the projected surface area that falls between:
 - (a) A horizontal plane that passes through the SRP and a horizontal plane 610 mm above the SRP; and
 - (b) A vertical longitudinal plane that passes through the inboard-most point of the seat cushion and a vertical longitudinal plane that passes through the outboard-most point of the seat cushion.

Use the following procedure for a typical trapezoidal shape:

- 6.1 Seat back width at 610 mm above the SRP height (A) = _____ mm
- 6.2 Seat back width at the SRP height (B) = _____ mm
- 6.3 Area = $1/2 (A + B) \times 610 \text{ mm} =$ _____ mm²

NOTE: For a seat back area that is not trapezoidal in shape or has a large radius at the corner(s), the above described measuring method (item 6.3) must be modified as required to obtain accurate area measurements. Include any additional measurements and calculations required to determine the surface area under REMARKS.

16. DATA SHEETS....Continued

7. Is item 6.1 greater than or equal to item 4? (S5.1.2)

_____ Yes – Pass _____ NO - FAIL

8. Is item 6.3 greater than or equal to item 5? (S5.1.2)

_____ Yes – Pass _____ NO - FAIL

REMARKS:

RECORDED BY: _____ ; DATE: _____

APPROVED BY: _____

16. DATA SHEETS....Continued

DATA SHEET 3
 RESTRAINING BARRIER POSITION AND PROJECTED REAR SURFACE AREA (S5.2.2)
 SCHOOL BUS NHTSA NO.: _____

SEAT NUMBER: _____

See Figure 9 from TP-222 for diagram.

1. Distance from SRP of seat immediately aft of barrier in a horizontal longitudinal line forward to barrier (X) = ____ mm
2. Is distance X equal to or less than 610 mm? (S5.2)
 ____ Yes - Pass ____ NO - FAIL
3. Measure distance U at inboard (i) and outboard (o) side of barrier.
 U_i = ____ mm U_o = ____ mm
4. Measure distance V at inboard and outboard sides of seat.
 V_i = ____ mm V_o = ____ mm
5. Is U_i equal to or less than V_i?
 ____ Yes - Pass ____ NO - FAIL
6. Is U_o equal to or less than V_o?
 ____ Yes - Pass ____ NO - FAIL
7. Maximum vertical height of the barrier above the SRP of the seat located immediately rearward of the barrier (S) = ____ mm
8. Is item 7 greater than or equal to 610 mm? (S5.2.2 and S5.1.2)
 ____ Yes - Pass ____ NO - FAIL
9. Maximum transverse width of the seat cushion of the seat immediately rearward of the barrier (W1) = ____ mm

16. DATA SHEETS....Continued

10. Calculate the following: $0.75 \times W1 = \underline{\hspace{2cm}}$ mm
11. Calculate the following: $0.90 \times W1 \times 610 \text{ mm} = \underline{\hspace{2cm}}$ mm²
12. Project the rear surface of the barrier onto a vertical transverse plane. Measure the projected surface area ($\pm 2\%$) that falls between the following planes, which are determined relative to the seat located immediately rearward of the barrier:
- (a) A horizontal plane that passes through the SRP and a horizontal plane 610 mm above the SRP; and
 - (b) A vertical longitudinal plane that passes through the inboard-most point of the seat cushion and a vertical longitudinal plane that passes through the outboard-most point of the seat cushion.

Use the following procedure for a typical trapezoidal shape:

- 12.1 Barrier width at 610 mm above the SRP height (A) = $\underline{\hspace{2cm}}$ mm
- 12.2 Barrier width at the SRP height (B) = $\underline{\hspace{2cm}}$ mm
- 12.3 Area = $1/2 (A + B) \times 610 \text{ mm} = \underline{\hspace{2cm}}$ mm²

NOTE: For a barrier area that is not trapezoidal in shape or has a large radius at the corner(s), the above described measuring method (item 12.3) must be modified as required to obtain accurate area measurements. Include any additional measurements and calculations required to determine the surface area under REMARKS.

13. Is item 12.1 greater than or equal to item 10? (S5.1.2)

Yes – Pass NO - FAIL

14. Is item 12.3 greater than or equal to item 11? (S5.1.2)

Yes – Pass NO - FAIL

REMARKS:

RECORDED BY: _____ ; DATE: _____

APPROVED BY: _____

16. DATA SHEETS....Continued

DATA SHEET 4
SEAT CUSHION LATCHING AND RETENTION TEST
SCHOOL BUS NHTSA NO.: _____

SEAT NUMBER: _____

1. Is the passenger seat cushion designed to be removable without tools or to flip up?
 Yes – Complete 1.1 through 1.3 No – Go to Item 2
 - 1.1 Is the seat equipped with a self-latching mechanism? (S5.1.5 (a))
 Yes – Pass NO – FAIL
 - 1.2 Release the seat cushion latching mechanism and lift the cushion away from the seat frame. Gently place the seat cushion back onto its frame. If the self-latching mechanism does not activate under the seat cushion's own weight, do not push down on the seat or force the mechanism to activate.
 - 1.3 Place a mass of 22 kg, with a force distribution pad of 102 mm radius, at the geometric center of the top of the seat cushion as to produce a vertical downward force of 215.75 N, -0, +4.45. (S5.1.5 (a))
 - 1.4 Remove the load from the top of the seat cushion.
2. Cushion Weight = _____ N (measured from a different seat of the same design as the test seat)
3. Cushion Weight x 5 = F = _____ N (S5.1.5 (b))
4. Using the upward load fixture with a force distribution pad of 102 mm radius (or a rectangular pad of equivalent area in cases where the circular pad cannot be used), apply a vertical upward force at the center of the cushion underside. Complete the following force/time graph.

16. DATA SHEETS....Continued

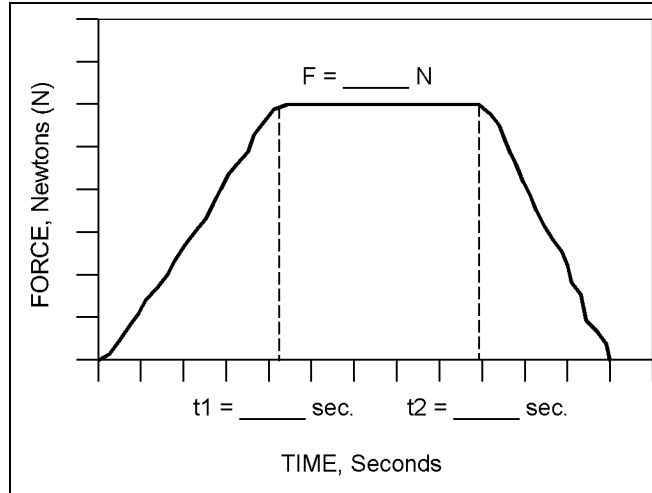

F must be 5 x Cushion Weight; t1 and t2 must be according to the following expressions:

1 sec.$t_1$$5$ sec., $t_2 = t_1 + 5</math> sec., + 1.0 sec. and - 0.0 sec.
(S5.1.5 (b))$

5. Did seat cushion separate from the seat structure at any attachment point? (S5.1.5 (b))

___ Yes - Pass ___ NO - FAIL

DESCRIBE SEAT CUSHION ATTACHMENTS:

REMARKS:

RECORDED BY: _____ ; DATE: _____

APPROVED BY: _____

16. DATA SHEETS....Continued

DATA SHEET 5
SEAT BACK FORCE DEFLECTION TEST - FORWARD
SCHOOL BUS NHTSA NO.: _____

SEAT NUMBER: _____

1. Seat Bench Width = _____ mm

$$W = (\text{Seat Bench Width})/381 \text{ (round to nearest whole number)} = \underline{\hspace{2cm}}$$
2. Seating Reference Point (SRP) location is: (Description of location as supplied by the manufacturer) _____
_____3. Location of lower loading bar is _____ mm above/below the SRP.
(Requirement: Between 102 mm above and 102 mm below the SRP) (S5.1.3.1)

Lower loading bar length = _____ mm

Seat back width at the SRP height = _____ mm

(Loading Bar Length = Seat Back Width – 102 mm, +13, -6.3)

4. Include x-y plot of Force vs. Time for the lower loading bar.

5. Deflection of the seat back at conclusion of lower bar loading (1557W position)
= _____ mm

6. Maximum deflection allowed without moving the seat back to within 102 mm of another seat or restraining barrier = _____ mm (must be 356 mm or less) (S5.1.3)

7. Seat back movement rate selected by the test engineer = _____ mps

8. Location of upper loading bar is in a horizontal plane _____ mm above the SRP. (Requirement: 406 mm) (S5.1.3.3)

Upper loading bar length = _____ mm

Seat back width at 406 mm above the SRP height = _____ mm

(Loading Bar Length = Seat Back Width – 102 mm, +13, -6.3)

16. DATA SHEETS....Continued

9. Reason for stopping seat back deflection:

- Reached deflection determined in item 5 above (if less than 356 mm)
 Reached 356 mm maximum allowed deflection
 Force exceeded 10676 N
 Separation was about to occur

10. Include the x-y plot of force vs. deflection for the upper loading bar with boundaries of Figure 14 superimposed.

11. Is the seat in its final deflected position within 102 mm of the next seat or barrier?

No - Pass YES - FAIL

12. Does the forward force vs. deflection trace of the seat back lie within the unshaded area? (S5.1.3)

Yes - Pass NO - FAIL

13. Include a deflection vs. time plot for the upper loading bar.

14. The area within the force vs. deflection curve = N-m

15. 452W = N-m (S5.1.3.4)

16. Is item 14 greater than or equal to item 15? (S5.1.3.4)

Yes - Pass NO - FAIL

REMARKS:

RECORDED BY: _____ ; DATE: _____

APPROVED BY: _____

16. DATA SHEETS....Continued

DATA SHEET 6
 RESTRAINING BARRIER FORCE/DEFLECTION TEST
 SCHOOL BUS NHTSA NO.: _____

BARRIER IDENTIFICATION: _____

1. Seat cushion width of seat immediately rearward of restraining barrier = _____ mm.
 $W = (\text{Seat Cushion Width})/381$ (round to nearest whole number) = _____
2. Location of SRP of seat rearward of restraining barrier is: (description of location as supplied by the manufacturer) _____

3. Location of lower loading bar is _____ mm above/below the SRP.
 (Requirement: between 102 mm above and 102 mm below the SRP) (S5.1.3.1)
 Lower loading bar length = _____ mm
 Barrier width at the SRP height = _____ mm
 (Loading Bar Length = Barrier Width – 102 mm, +13, -6.3)
4. Include x-y plot of Force vs. Time for the lower loading bar.
5. Deflection of the barrier at the conclusion of lower bar loading (1557W position) = _____ mm.
6. Maximum deflection allowed without moving the restraining barrier to within interference of door operation = _____ mm (must be 356 mm or less).
7. Barrier movement rate selected by the test engineer = _____ mm/sec
8. Location of upper loading bar is in a horizontal plane _____ mm above the SRP. (Requirement: 406 mm) (S5.1.3.3)
 Upper loading bar length = _____ mm
 Barrier width at 406 mm above the SRP height = _____ mm
 (Loading Bar Length = Barrier Width – 102 mm, +13, -6.3)

16. DATA SHEETS....Continued

9. Reason for stopping restraining barrier deflection:

- Reached 356 mm maximum
 Force exceeded 10676 N
 Separation was about to occur
 Interference with door operation

10. Maximum deflection of barrier _____ mm.
 (Requirement: maximum allowed is 356 mm) (S5.2.3(b))

11. Does the restraining barrier interfere with the normal operation of the door? (S5.2.3(c))

No - Pass YES - FAIL

12. Did any separation of barrier component or the separation of the barrier from the vehicle occur? (S5.1.3 (d) & (e))

No - Pass YES - FAIL

13. Include the x-y plot of force vs. deflection for the upper loading bar with boundaries of Figure 14 (TP-222) superimposed.

14. Does the forward force vs. deflection trace of the barrier back lie within the unshaded area? (S5.2.3(a))

Yes - Pass NO - FAIL

15. Include a deflection vs. time plot for the upper loading bar.

16. The area within the force vs. deflection curve = _____ N-m

17. 452W = _____ N-m (S5.2.3) (S5.1.3.4)

18. Is item 16 greater than item 17?

Yes - Pass NO - FAIL

REMARKS:

RECORDED BY: _____ ; DATE: _____

APPROVED BY: _____

16. DATA SHEETS....Continued

DATA SHEET 7
SEAT BACK FORCE DEFLECTION TEST - REARWARD
SCHOOL BUS NHTSA NO.: _____

SEAT NUMBER: _____

1. Seat Bench Width = _____ mm

W = (Seat Bench Width)/381 (round to nearest whole number) = _____

2. Location of the loading bar is in a horizontal plane _____ mm above the SRP of the test seat.
(Requirement: 343 mm above SRP) (S5.1.4.1)

Loading bar length = _____ mm

Seat back width at 343 mm above the SRP height = _____ mm
(Loading Bar Length = Seat Back Width – 102 mm, +13, -6.3)

3. Deflection of seat back at 222 N preload = _____ mm

4. Maximum deflection allowed without moving the seat back to within 102 mm of another seat = _____ mm (maximum allowed = 254 mm) (S5.1.4)

5. Seat back movement rate selected by the test engineer = _____ mm/sec

6. Reason for stopping deflection:

_____ Reached deflection determined in item 3 above

_____ Reached 254 mm maximum allowed deflection

_____ Force exceeded 9786 N

_____ Separation was about to occur

7. Include the x-y plot of force vs. deflection for the loading bar with the boundaries of Figure 18 (TP-222) superimposed.

8. Does the force vs. deflection plot lie within the boundaries of Figure 18 (TP-222)?

_____ Yes - Pass

_____ NO - FAIL

9. Include the deflection vs. time plot for the loading bar.

16. DATA SHEETS....Continued

10. 316W = _____ N-m

11. The area within the force vs. deflection curve = _____ N-m

12. Is item 11 greater than or equal to item 10? (S5.1.4.2)

_____ Yes - Pass

_____ NO - FAIL

REMARKS:

RECORDED BY: _____ ; DATE: _____

APPROVED BY: _____

16. DATA SHEETS....Continued

DATA SHEET 8
 HEAD FORM IMPACT CONTACT AREA REQUIREMENT
 SCHOOL BUS NHTSA NO.: _____

SEAT NUMBER: _____

BARRIER IDENTIFICATION: _____

1. Locate x-y reference point on sketch above for head form impact locations. (Label the positive and negative directions, if applicable)
2. Identify head form impact location on sketch by placing H1, H2, H3, H4, H5, H6 and H7 in the appropriate location.
3. Define the plane of reference for head form impact angle: _____

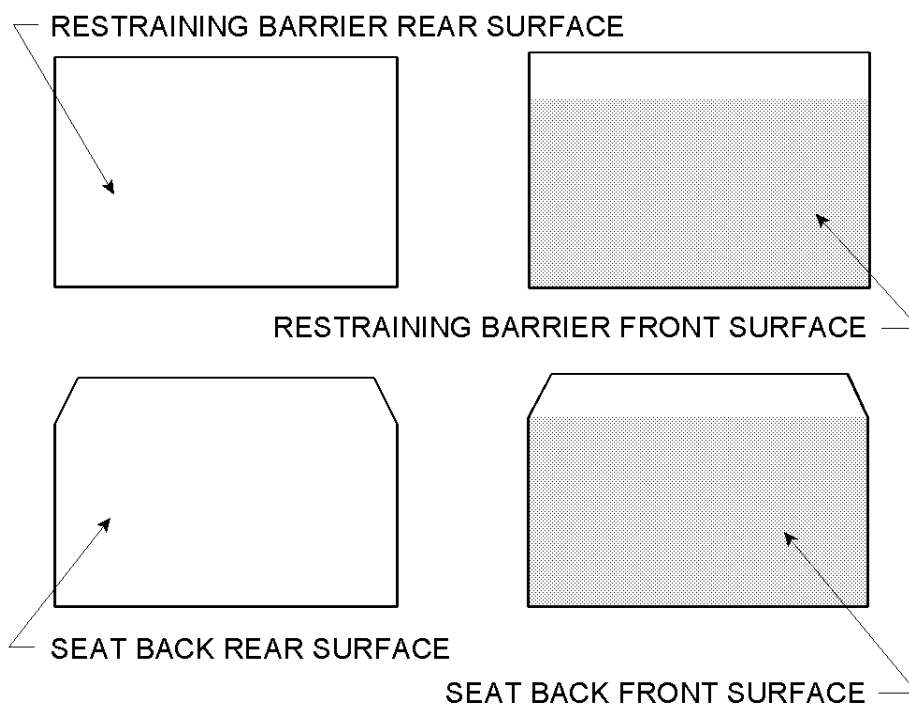

16. DATA SHEETS....Continued

4. Complete the following table:

(1)	(2)			(3)	(4)*	(5)	(6)	(7)
HEAD IMPACT	LOCATION			SPEED TRAP IMPACT VELOCITY**	DERIVED VELOCITY	CONTACT AREA (CA)	CA ≥ 1935 mm ²	
	X	Y	ANGLE				YES - PASS	NO - FAIL
H1								
H2								
H3								
H4								
H5								
H6								
H7								

* Contact Velocity from Item 7 below; ** Velocity Range = 1.52 mps, +0.076, -0

- 5. Attach Contact Area Prints.
- 6. Attach acceleration versus time plots for each impact.
- 7. Integrate the acceleration versus time plots and attach plots of the results that show velocity versus time.

REMARKS:

RECORDED BY: _____ ; DATE: _____

APPROVED BY: _____

16. DATA SHEETS....Continued

DATA SHEET 9
HEAD FORM IMPACT ENERGY REQUIREMENT
SCHOOL BUS NHTSA NO.: _____

SEAT NUMBER: _____

BARRIER IDENTIFICATION: _____

1. Locate x-y reference point on sketch above for head form impact locations. (Label the positive and negative directions, if applicable)
2. Identify head form impact location on sketch by placing H1, H2, H3, H4, H5, H6 and H7 in the appropriate location.
3. Define the plane of reference for head form impact angle: _____

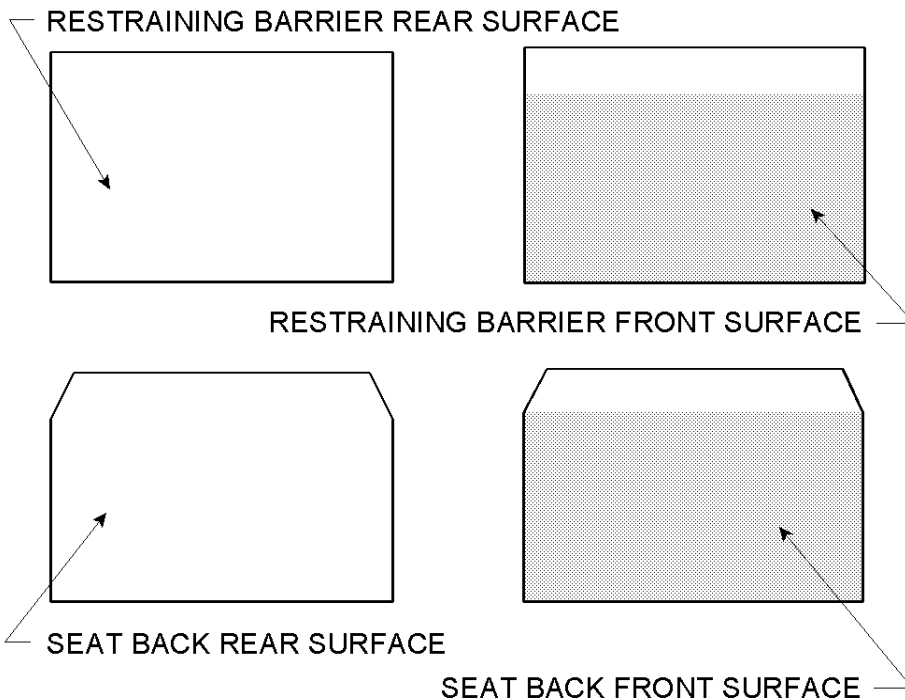

16. DATA SHEETS....Continued

4. Complete the following table:

(1)	(2)			(3)	(4)*	(5)	(6)	(7)		(8)	
HEAD IMPACT	LOCATION			SPEED TRAP IMPACT VELOCIT Y**	DERIVED VELOCITY **	MAX HIC	ENGY REQD	COLUMN 5 < 1000		COLUMN 6 > 4.5 N-m	
	X	Y	ANGLE					YES - PASS	NO - FAIL	YES - PASS	NO - FAIL
H1											
H2											
H3											
H4											
H5											
H6											
H7											

* Impact Velocity from Item No. 6 below

** Impact Velocity Range = 6.69 mps, +0, -0.076

- 5. Attach acceleration versus time plots for each impact.
- 6. Integrate the acceleration versus time plots and attach plots of the results that show velocity versus time.

REMARKS:

RECORDED BY: _____ ; DATE: _____

APPROVED BY: _____

16. DATA SHEETS....Continued

DATA SHEET 10
KNEE FORM IMPACT TEST
SCHOOL BUS NHTSA NO.: _____

SEAT NUMBER: _____

BARRIER IDENTIFICATION: _____

1. Locate x-y reference point on sketch above for knee form impact locations.
(Label the positive and negative directions, if applicable)
2. Identify knee form impact location on sketch by placing K1, K2, K3, K4, K5, K6, K7 and K8 in the appropriate location.
3. Define the plane of reference for knee form impact angle: _____

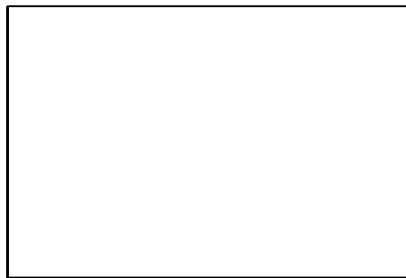

RESTRAINING BARRIER REAR SURFACE

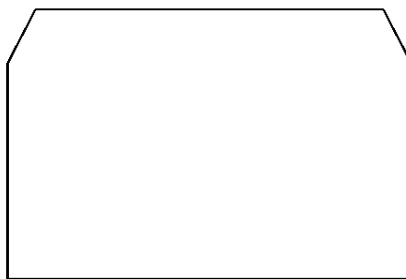

SEAT BACK REAR SURFACE

16. DATA SHEETS....Continued

4. Complete the following table:

(1)	(2)			(3)	(4)*	(5)	(6)	(7)		(8)	
KNEE IMPACT	LOCATION			SPEED TRAP IMPACT VELOCIT Y**	DERIVED VELOCITY **	CONT AREA mm ²	RESI ST FORC E	COLUMN 5 > 1935 mm ²		COLUMN 6 < 2669 N	
	X	Y	ANGLE					YES - PASS	NO - FAIL	YES - PASS	NO - FAIL
K1											
K2											
K3											
K4											
K5											
K6											
K7											
K8											

* Impact Velocity from Item 7 below

** Velocity Range = 4.86 mps, +0.076, -0.0 for contact area (K1 through K4)
 Velocity Range = 4.86 mps, +0, -0.076 for force (K5 through K8)

5. Attach Contact Area Prints for K1 through K4.
6. Attach acceleration versus time plots for each impact.
7. Integrate the acceleration versus time plots and attach plots of the results that show velocity versus time for each plot K1 through K8.
8. Attach force versus time plots for K5 though K8.

REMARKS:

RECORDED BY: _____ ; DATE: _____

APPROVED BY: _____

16. DATA SHEETS....Continued

DATA SHEET 11
ADMINISTRATIVE DATA SHEET

TESTED FOR: U.S. Department of Transportation
National Highway Traffic Safety Administration

CONTRACT NO.: DTNH22-_____ ; TESTING CLASSIFICATION: Compliance

DESCRIPTION OF TEST VEHICLE:

- A. Incomplete Vehicle (if applicable)
- 1 - Manufacturer
 - 2 - Model
 - 3 - Vehicle Identification Number (VIN)
 - 4 - Build Date
 - 5 - Certification Date
- B. Completed Vehicle
- 1 - Model Year/Make/Model
 - 2 - Vehicle Body Style
 - 3 - Vehicle Identification Number (VIN)
 - 4 - NHTSA number
 - 5 - Color
 - 6 - GVWR
 - 7 - Manufacturer
 - 8 - Build Date
 - 9 - Certification Date

DATES:

- 1 - Vehicle Receipt
- 2 - Start of Test
- 3 - Completion of Test

TEST VEHICLE DISPOSITION:

TEST: All tests were performed in accordance with the references outlined in FMVSS 222 as published in the Federal Register, Volume 41, No. 19, Jan 28, 1976, and as amended in 41FR28528, Jul 12, 1976; 41FR36027, Aug 26, 1976; 41FR54945, Dec 16, 1976; 42FR64120, Dec 23, 1977; 43FR9150, Mar 6, 1978; 44FR18675, Mar 29, 1979; and 48FR12386, Mar 24, 1983.

THE ABOVE NOTED ADMINISTRATIVE DATA SHEET IS TO BE INCLUDED IN THE FRONT OF THE FINAL REPORT ALONG WITH THE STANDARD TITLE PAGE.

17. FORMS

LABORATORY NOTICE OF TEST FAILURE TO OVSC

FMVSS: 222 TEST DATE: _____

LABORATORY: _____

CONTRACT NO.: _____ DELV. ORDER NO.: _____

LABORATORY PROJECT ENGINEER'S NAME: _____

SCHOOL BUS DESCRIPTION: _____

BUS NHTSA NO.: _____ VIN: _____

MFR: _____

TEST FAILURE DESCRIPTION: _____

FMVSS REQUIREMENT, PARAGRAPH S ____ : _____

NOTIFICATION TO OVSC (COTR): _____

DATE: _____ BY: _____

REMARKS:

17. FORMS....Continued

MONTHLY TEST STATUS REPORT
FMVSS 222
DATE OF REPORT: _____

No.	SCHOOL BUS NHTSA No., MAKE & MODEL	COMPLIANCE TEST DATE	PASS/ FAIL	DATE REPORT SUBMITTED	DATE INVOICE SUBMITTED	INVOICE PAYMENT DATE
1						
2						
3						
4						
5						
6						
7						
8						
9						
10						

17. FORMS....Continued

MONTHLY VEHICLE STATUS REPORT
FMVSS 222
DATE OF REPORT: _____

No.	SCHOOL BUS NHTSA No., MAKE & MODEL	DATE OF DELIVERY	ODOMETER READING	TEST COMPLETE DATE	VEHICLE SHIPMENT DATE	ODOMETER READING
1						
2						
3						
4						
5						
6						
7						
8						
9						
10						

APPENDIX A
FMVSS 210 – SEAT BELT ASSEMBLY ANCHORAGES
FOR CLASS 2 SCHOOL BUSES

A7. CALIBRATION OF TEST INSTRUMENTS

TEST EQUIPMENT ACCURACY

EQUIPMENT	RANGE	ACCURACY
Hydraulic Rams (3 Req'd)	0-120% of Specified Load	N/A
Load Cells (3 Req'd)	0-120% of Readout Capability	± 0.5%
Strip Chart Recorder	Readout Capability of 3% of Maximum Load	± 1.0%
Hydraulic Pump	Approx. 14.4 liters/min.	N/A
DC Power Supply	Adequate for Load Cells Used	Line Reg. of 0.05% (105 to 125 v) Load Reg. of 0.05% (0 to Full) Ripple: 5 mv P/P Stability: 0.1%
Digital Voltmeter or Equivalent Used to Monitor Load Cell Outputs	4 Digit Readout	± 0.1%
Signal Conditioning and Calibration Units	Adequate for Load Cells Used	± 0.5%
H-Point Machine	N/A	N/A
Steel Scale	914 mm Minimum	± 2.54 mm

APPENDIX A....Continued

A10 DEFINITIONS

CURB WEIGHT

Weight of a motor vehicle with standard equipment; maximum capacity of engine fuel, oil and coolant; and, if so equipped, air conditioning and additional weight optional engine.

DESIGNATED SEATING POSITION (DSP)

Any plan view location capable of accommodating a person at least as large as a 5th percentile adult female, if the overall seat configuration and design and vehicle design is such that the position is likely to be used as a seating position while the vehicle is in motion, except for auxiliary seating accommodations such as temporary or folding jump seats.

H-POINT

Mechanically hinged hip point of a manikin which simulates the actual pivot center of the human torso and thigh, described in SAE J826

H-POINT TEMPLATE

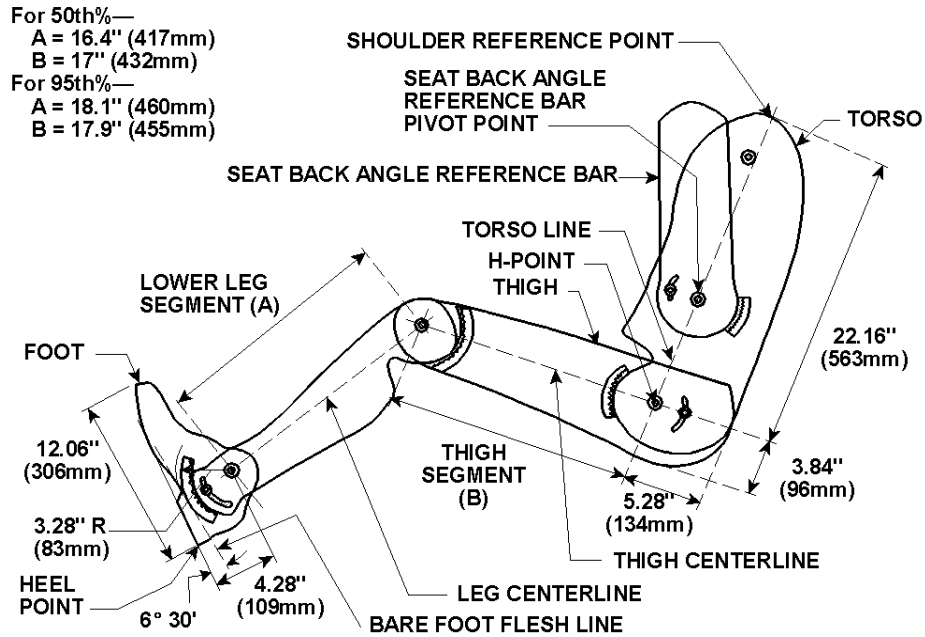

APPENDIX A....Continued**SEAT BELT ASSEMBLY**

Any strap, webbing or similar device designed to secure a person in a motor vehicle in order to mitigate the results of any accident, including all necessary buckles and other fasteners, and all hardware designed for installing such seat belt assembly in a motor vehicle.

SEAT BELT ASSEMBLY ANCHORAGE

Provision for transferring seat belt assembly loads to the vehicle structure.

SEATING REFERENCE POINT (SRP)

Manufacturer's Design Reference Point which –

- A. Establishes the rearmost normal design driving or riding position of each DSP in a vehicle;
- B. Has coordinates established relative to the designed vehicle structure;
- C. Simulates the position of the center pivot of the human torso and thigh; and
- D. Is the reference point employed to position the 2 dimensional templates described in SAE Recommended Practice J826, Manikins for use In Defining Vehicle Seating Accommodation.

SHOULDER REFERENCE POINT (SHRP)

A point 563 mm above the H-Point along the torso centerline of the 2 dimensional drafting template described in SAE J383 -- IT DOES NOT DESCRIBE A SHOULDER JOINT

TORSO LINE

Line connecting the H-Point and the SHRP as defined in SAE Recommended Practice J383, Motor Vehicle Seat Belt Anchorage.

APPENDIX A....Continued

TYPE 1 SEAT BELT ASSEMBLY

Lap belt assembly for occupants pelvic or lower body restraint.

TYPE 2 SEAT BELT ASSEMBLY

A combination of pelvic (lap belt) and upper torso (shoulder belt) restraints.

A12 COMPLIANCE TEST EXECUTION

GENERAL STATEMENT OF REQUIREMENTS

Establishes requirements for Seat Belt Assembly Anchorages. Those requirements are detailed in Title 49 Code of Federal Regulations Part 571.210.

TEST EQUIPMENT DESCRIPTION

- A. A test loading, monitoring, and control system which shall consist of a maximum of three load cells, with one load cell mounted on each body block measuring the force applied. Force control shall be derived from a closed loop programmable force generator and shall be capable of simultaneously supplying loads to a maximum of three separate body blocks at a constant rate. In addition, if any seat belts or cables used in lieu of seat belts fail during the test, the change in the rate of loading on the remaining anchorages shall be minimal.

Recorded data shall include preload, loading, and unloading of the anchorages at the end of the holding period. The measured force at each body block shall be applied and controlled at a rate less than the maximum rate specified (220,000 newtons per second) in S210. If all loading devices are not connected to the same load source, the application rate difference shall not exceed five percent. The maximum force, maintained for the time interval specified, shall be within -44.5, -222 newtons of the standard's specified maximum value. The loading apparatus shall be mounted so that it is sturdy enough to adequately withstand the loads applied and so that it will load the anchorages at the required angles.

APPENDIX A....Continued

NOTE: IT IS IMPORTANT TO NOTE THAT A MAXIMUM OF 3 SEPARATE LOADING DEVICES ARE REQUIRED AND A PLOT OF LOAD VERSUS TIME MUST BE GENERATED DURING THE TEST OR FROM REAL TIME CONTINUOUS MEASUREMENTS RECORDED AND STORED DURING THE TEST.

B. Three (3) lap belt blocks shown on the next page.

NOTE: LAP BELT BODY BLOCK WILL BE COVERED BY 25.4 mm MEDIUM DENSITY CANVAS COVERED FOAM RUBBER WHERE LAP BELT CONTACTS BODY BLOCK.

C. Appropriate angle, length, width, height, etc. measuring devices.

D. Restraining device or fixture to completely tie-down and immobilize the test vehicle when applying the required anchorage loads.

E. System to raise and hold the test vehicle at least 25.4 mm above the floor level, if the loading device is mounted outside the bus.

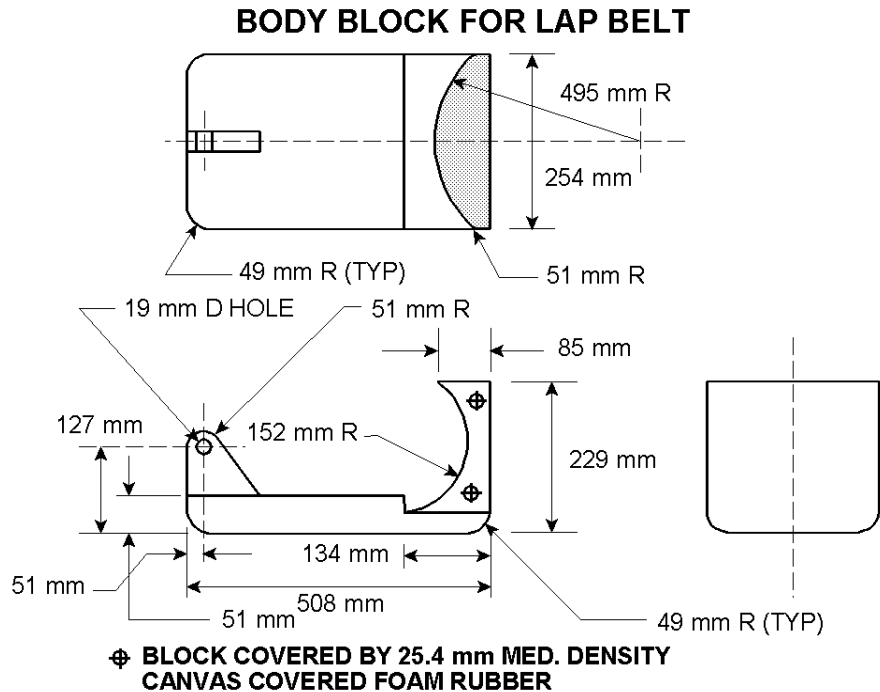

APPENDIX A....Continued

- F. A SAE two dimensional manikin or equivalent device to determine the shoulder belt reference point -- SHRP (see SAE J826).
- G. A camera to provide pertinent still photographs, which as a minimum, should include the photographs listed in this procedure.

SEQUENCE FOR SEAT BELT ASSEMBLY ANCHORAGE TESTS

The test vehicles shall be subjected to the tests in the order shown below:

- A. Dimensional measurements
- B. Static load testing of seat belt assembly anchorages

DIMENSIONAL MEASUREMENTS

The number of Designated Seating Positions (DSP) specified on the test vehicle's tire information label or placard shall be recorded on Data Sheet A1, and the number of seat belt systems in the vehicle compared with this figure (DSPs stipulated for the maximum loading capacity). The type of seat belt system installed at each DSP shall also be recorded on Data Sheet A1.

Measurements shall be made of the lateral spacing of the anchorages for individual seat belt assemblies and recorded on Data Sheet A2. The anchorages for an individual seat belt assembly must be at least 165 mm apart.

Next, the angle from the SRP to the belt attachment hardware shall be measured using the sketch shown below as a guide for the inboard and outboard anchorages at each DSP. Seat back angle and SRP data for each test vehicle will be obtained by the COTR from each manufacturer. Record the information on Data Sheet A3.

APPENDIX A....Continued

ANCHORAGE/SRP LOCATIONS

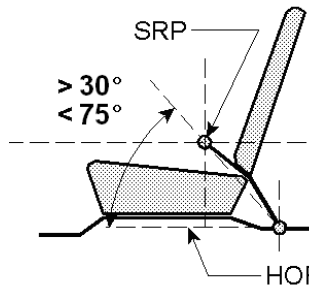
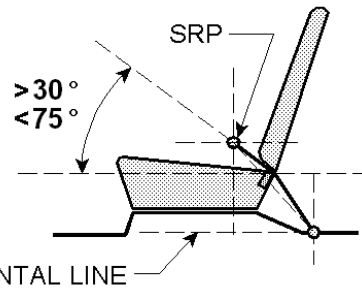
BELT OUTSIDE SEAT
OR THROUGH SEATSEAT BELT OVER
SEAT CROSSBAR

REAR SEAT

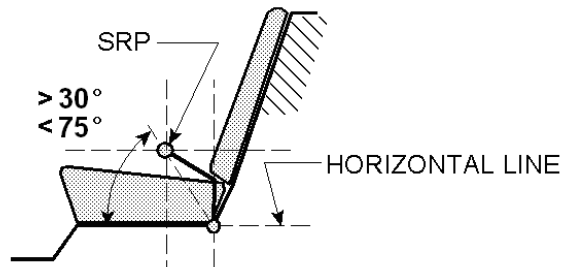

STATIC LOAD TESTING OF SEAT BELT ASSEMBLY ANCHORAGES

A. PREPARATION OF TEST VEHICLE

- (1) MODIFICATIONS MADE TO THE VEHICLE IN ORDER TO PERFORM THE TEST SHALL BE KEPT TO A MINIMUM.
- (2) Attach seat belts around the body block(s). If necessary, replace the seat belt webbing in the area of the body blocks with wire rope (COTR must first give permission to use wire rope).
 - (A) Position the seat belts around the body blocks
 - (B) Mark the seat belts at the length necessary to position the body blocks

APPENDIX A....Continued

- (C) Replace the safety belt webbing in the areas that will come into contact with the body block. Remove the buckles that will incur side loading from the body blocks. Retain all hardware which attaches the safety belt webbing to the anchorages. Attach wire rope securely to the remaining webbing and buckle hardware.
- (3) Attach the load cells to the body block load application cables, and connect the load application device to the load cells. The load application devices shall be positioned such that the angle of pull is $10^{\circ} \pm 5^{\circ}$ above the horizontal. The plane of load application in the plan view shall be adjusted parallel to the test vehicle centerline $\pm 3^{\circ}$.
- (4) Perform and record pretest zero and calibration settings on instrumentation prior to testing, and document for inclusion in the final report. Provide tolerance range indicators on the tracings, chart, or data paper, and provide tolerance range indicators on instruments so that if the test is video taped it shall be apparent that the test was conducted within the test procedure requirements. Identify each recording with date, time, vehicle, test technicians, NHTSA Number, chart speed, if applicable, FMVSS Number, X and Y axes names, units of measure and instrument settings. Record the serial numbers of equipment used for each specific load application location.

B. TEST PERFORMANCE

- (1) The pelvic portion of type one seat belt assemblies shall be loaded to 22,000 newtons. The load tolerance for each shall be -44 to -220 newtons. A seat with three DSP's shall have all three belt systems tested. The test results shall be recorded on Data Sheet A4.
- (2) Seat Belt Assemblies That Attach to the Seats -- Simultaneously apply the appropriate load from item B.(1)
- (3) Two seats shall have the seat belt assembly anchorages load tested. Remove seat(s), if necessary to allow access to the test seats.

APPENDIX A....Continued

- (4) For each belt load application, all forces shall be adjusted to 10% of target load. While at this load level, photographs and measurements of the load application angles shall be taken. The load application angles shall be recorded on Data Sheet A5. The load shall then be increased to 100% of the target load. After holding the load for a minimum of 10 seconds (load application time from 10% of load can not exceed 30 seconds), the test loads shall be released, anchorages inspected, and all post test photographs taken.
- (5) Perform and record post test zero and calibration checks.
- (6) Descriptions of test vehicle damage resulting from the anchorage loadings shall be recorded on the Report of Vehicle Condition at the Completion of Testing form and included in the final report. Permanent deformation, including rupture or breakage, of any anchorage or surrounding area may not constitute a failure. Any anomalies shall be reported immediately to the COTR prior to the next step in testing.
- (7) If the seat belt webbing at a particular DSP breaks during the test, the anchorage test for that DSP is terminated at that point and so noted on the data sheet. This would also apply to failed webbing hardware such as buckles and latch plates. Testing of unbroken belts at the other DSPs shall continue to completion.
- (8) Where requirements are not specified, testing shall be performed using good engineering judgment.

APPENDIX A....Continued

DATA SHEET A1
SEAT BELT ASSEMBLY ANCHORAGE INSTALLATION TYPES

VEH. MOD YR/MAKE/MODEL/BODY: _____

VEH. NHTSA NO.: _____ ; VIN: _____

VEH. BUILD DATE: _____ ; TEST DATE: _____

TEST LABORATORY: _____

OBSERVERS: _____

SEAT NUMBER	SEATING POSITION	SEAT FACING	REQUIRED ANCHORAGE	OBSERVED ANCHORAGE
	Outboard - Left	Forward	Type 1	
	Center	Forward	Type 1	
	Outboard - Right	Forward	Type 1	
	Outboard - Left	Forward	Type 1	
	Center	Forward	Type 1	
	Outboard - Right	Forward	Type 1	

REMARKS:

RECORDED BY: _____ DATE: _____

APPROVED BY: _____

APPENDIX A....Continued

DATA SHEET A2
LATERAL SPACING OF SEAT BELT ASSEMBLY ANCHORAGES

VEH. MOD YR/MAKE/MODEL/BODY: _____

VEH. NHTSA NO.: _____ ; VIN: _____

VEH. BUILD DATE: _____ ; TEST DATE: _____

TEST LABORATORY: _____

OBSERVERS: _____

SEAT NUMBER	ANCHORAGE LOCATION	MEASURED SPACING
	Left Outer - Left Inner Center Left - Center Right Right Inner - Right Outer	
	Left Outer - Left Inner Center Left - Center Right Right Inner - Right Outer	

NOTE: The spacing for an individual seat belt assembly anchorage shall be at least 165 mm apart as measured between the vertical centerlines of the bolt holes.

REMARKS:

RECORDED BY: _____ DATE: _____

APPROVED BY: _____

APPENDIX A....Continued

DATA SHEET A3
SEAT BELT ANGLES

VEH. MOD YR/MAKE/MODEL/BODY: _____

VEH. NHTSA NO.: _____ ; VIN: _____

VEH. BUILD DATE: _____ ; TEST DATE: _____

TEST LABORATORY: _____

OBSERVERS: _____

LAP BELT ANCHORAGES:

SEAT NUMBER	SEATING POSITION	SPECIFIED ANGLE RANGE ABOVE HORIZONTAL	MEASURED ANGLE
	Left	30 to 75 degrees	
	Center	30 to 75 degrees	
	Right	30 to 75 degrees	
	Left	30 to 75 degrees	
	Center	30 to 75 degrees	
	Right	30 to 75 degrees	

REMARKS:

RECORDED BY: _____ DATE: _____

APPROVED BY: _____

APPENDIX A....Continued

DATA SHEET A4
LAP AND SHOULDER BELT ASSEMBLY ANCHORAGE LOADINGS

VEH. MOD YR/MAKE/MODEL/BODY: _____

VEH. NHTSA NO.: _____ ; VIN: _____

VEH. BUILD DATE: _____ ; TEST DATE: _____

TEST LABORATORY: _____

OBSERVERS: _____

SEAT NUMBER	BELT ASSEMBLY TESTED	MAXIMUM LOAD REQUIREMENT	APPLIED LOAD
	Left Lap	22,000 N, -44, -220	
	Right Lap	22,000 N, -44, -220	
	Center Lap	22,000 N, -44, -220	
	Left Lap	22,000 N, -44, -220	
	Right Lap	22,000 N, -44, -220	
	Center Lap	22,000 N, -44, -220	

REMARKS:

RECORDED BY: _____ DATE: _____

APPROVED BY: _____

APPENDIX A....Continued

DATA SHEET A5

SEAT BELT ASSEMBLY LOAD ANGLE MEASUREMENT

VEH. MOD YR/MAKE/MODEL/BODY: _____

VEH. NHTSA NO.: _____ ; VIN: _____

VEH. BUILD DATE: _____ ; TEST DATE: _____

TEST LABORATORY: _____

OBSERVERS: _____

TYPE	ANGLE MEASURED	ANGLE REFERENCE	ANGLE AT 10% LOAD (degrees)					
			LEFT DSP		CNTR DSP		RIGHT DSP	
			SEAT#	SEAT#	SEAT#	SEAT#	SEAT#	SEAT#
LAP BELT	Load Application Angle (degrees)	From Side View Horizontal 10° ± 5°						
		From Plan View Vehicle Centerline 0° ± 3°						

REMARKS:

RECORDED BY: _____ DATE: _____

APPROVED BY: _____

APPENDIX A....Continued

DATA SHEET A6
TEST VEHICLE RECEIVING-INSPECTION

VEH. MOD YR/MAKE/MODEL/BODY: _____

VEH. NHTSA NO.: _____ ; VIN: _____

VEH. BUILD DATE: _____ ; TEST DATE: _____

TEST LABORATORY: _____

OBSERVERS: _____

- 1. Without disturbing the integrity of each seat belt and anchorage, verify that each seat belt is attached to the anchorage. For seat belts that are attached to the seat, also verify the seats are attached to the seat anchors and the seat anchors are attached to the vehicle.

_____ Yes - No Problems

_____ No - Problems

- 2. COMMENTS: (Explain any problems here)

RECORDED BY: _____

DATE: _____

APPROVED BY: _____

APPENDIX B

FMVSS 208, OCCUPANT CRASH PROTECTION
FOR CLASS 2 SCHOOL BUSES

B9 PHOTOGRAPHIC DOCUMENTATION

1. Front Seat, Driver Side - 95%M dummy with seat forward
2. Front Seat, Driver Side - 95%M dummy with seat rearward
3. Front Seat, Driver Side - 5%F dummy with seat forward
4. Front Seat, Driver Side - 5%F dummy with seat rearward
5. Front Seat, Passenger Side - 95%M dummy with seat forward
6. Front Seat, Passenger Side - 95%M dummy with seat rearward
7. Front Seat, Passenger Side - 50%C dummy with seat forward
(lap belt usage only)
8. Front Seat, Passenger Side - 50%C dummy with seat rearward
(lap belt usage only)
9. Rear Seat, Outboard Position - 95%M dummy
10. Rear Seat, Outboard Position - 50%C dummy
(lap belt only)

APPENDIX B....Continued

4. Single point, push-button, accessible latch release at each passenger DSP
(571.208 S7.2(c))

PASS = single point push-button

FAIL = not single point push-button

SEAT NO.								
DSP #1								
DSP #2								
DSP #3								
DSP #4								

5. Latch plate and buckle must not pass through conduit or guide between seat cushion and seat back at each passenger DSP. (571.208 S7.4.6)

PASS = latch plate and/or buckle will not fit through conduit or guide

FAIL = latch plate and/or buckle will fit through conduit or guide

SEAT NO.								
DSP #1								
DSP #2								
DSP #3								
DSP #4								

APPENDIX B....Continued

6.0 Either the latchplate, buckle, or webbing must stay on top or above the seat when the seat belt is unbuckled and the remaining two parts must stay accessible at each passenger DSP. (571.208 S7.4.6)

PASS = the seat belt meets the above requirements

FAIL = the seat belt does not meet the above requirements

SEAT NO.								
DSP #1								
DSP #2								
DSP #3								
DSP #4								

7. Seat Belt Fit Test Dummies

		MANUFACTURER	SERIAL NUMBER
7.1	50% 6-YEAR OLD CHILD		
7.2	5% ADULT FEMALE		
7.3	50% ADULT MALE		
7.4	95% ADULT MALE		

APPENDIX B....Continued

8. Seat belt must fit persons whose dimensions range from those of a 50th percentile 6-year old child to those of a 95th percentile adult male. (571.208 S7.1.1)

Two seats checked

PASS = snug fitting seat belt FAIL = loose fitting seat belt

SEAT NUMBER			
DSP #1	50% C		
	95% AM		
DSP #2	50% C		
	95% AM		
DSP #3	50% C		
	95% AM		
DSP #4	50% C		
	95% AM		

9. Driver's Seat (Not part of FMVSS 222)

1 Belt Type: ___ - 1 ___ - 2

2 Automatic Restraint: ___ - Yes ___ - No

3 Type of Automatic Restraint (if applicable) _____

4 PASS = snug fitting seat belt (571.208 S7.1.1.1)

FAIL = loose fitting seat belt

5%AF

95%AM

RECORDED BY: _____ DATE: _____

APPROVED BY: _____

APPENDIX B....Continued

DATA SHEET B2
SEAT BELT WARNING SYSTEM CHECK

NHTSA No.: _____; Technician: _____; Date: _____

1. Leave driver seat belt disconnected.
 - A. Place ignition switch in "ON" or "START" position
 - B. Measure time duration of continuous or intermittent audible warning signal operation.
_____ (4 to 8 seconds required 571.208 S4.5.3.3(b) & S7.3)
 - C. Measure time duration of continuous or flashing reminder light
_____ (4 to 8 seconds for active belts 571.208 S7.3)
(60 seconds or more for passive belts 571.208 S4.5.33)

2. Put occupant in driver's position and attach seat belt.
 - A. Place ignition switch in "ON" or "START" position.
 - B. Measure time duration of continuous or intermittent audible warning signal operation.
_____ (should not operate)
 - C. Measure time duration of continuous or flashing reminder light
_____ (4 to 8 seconds for active belts 571.208 S7.3)
(not required for passive belt unless the webbing is not in its locked, protective mode at the anchorage point)

APPENDIX B....Continued

3. Record exactly the wording of the visual seat belt warning system:

(The warning can only be "FASTEN SEAT BELT", "FASTEN BELTS", or the SYMBOL from FMVSS 101.)

REMARKS:

Recorded By: _____

Date: _____

Approved By: _____

APPENDIX C
WHEELCHAIR SECUREMENT ANCHORAGES AND DEVICES
WHEELCHAIR OCCUPANT RESTRAINT ANCHORAGES AND RESTRAINTS
FMVSS 222
APPLICABLE TO SCHOOL BUSES WITH WHEELCHAIR LOCATION ONLY

C1 TEST EQUIPMENT DESCRIPTION

The following is a list of the minimum suggested test equipment needed to evaluate the minimum performance requirements as outlined in S5.4 of S222.

- A. A hydraulic ram capable of generating the pull-force levels called for in S222 (S5.4.1 and S5.4.3).
- B. Loads cells to measure force levels called for in S222 (S5.4.1 and S5.4.3).
- C. Appropriate angle, length, width, height, etc. measuring devices.

Recorded data shall include preload, loading, and unloading of the anchorages at the end of the holding period. The measured force at each anchorage shall be applied and controlled at a rate less than the maximum onset rate specified (133,440 newton per second for a wheelchair anchorage, or a wheelchair occupant restraint floor anchorage; 66720 newton per second for a wheelchair occupant upper torso restraint anchorage) in S222. The maximum specified force value, maintained for the time interval specified, shall be within a tolerance of +0, -1 percent. The loading apparatus shall be mounted so that it is sturdy enough to withstand the loads applied and so that it will load the anchorage at the required angle.

It is important to note that only 1 loading device (hydraulic ram) and 1 load cell is allowed for each test to ensure smooth load application and recording. A plot of load versus time must be generated during the test or real time continuous measurements recorded and stored during the test.

C2 DEFINITIONS

TYPE A ANCHORAGE

Wheelchair securement anchorage which transfers ONLY the wheelchair inertia loads to the vehicle structure.

APPENDIX C....Continued**TYPE B ANCHORAGE**

Wheelchair occupant pelvic and upper torso restraint floor anchorage which transfers ONLY the wheelchair occupant inertia loads to the vehicle structure.

TYPE C ANCHORAGE

Common anchorage for the wheelchair securement device and wheelchair occupant restraint; transfers both the wheelchair and its occupant inertia loads to the vehicle structure.

TYPE D ANCHORAGE

Upper torso restraint anchorage for the upper end of wheelchair occupant torso restraint; transfers wheelchair occupant inertia loads to the vehicle structure.

WHEELCHAIR

A wheeled seat frame for the support and conveyance for a physically disabled person, comprised of at least a frame, seat, and wheels (S4.2).

WHEELCHAIR OCCUPANT RESTRAINT ANCHORAGE

The provision for transferring wheelchair occupant restraint system loads to the vehicle structure (S4.3).

WHEELCHAIR SECUREMENT ANCHORAGE

The provision for transferring wheelchair securement device loads to the vehicle structure (S4.4).

WHEELCHAIR SECUREMENT DEVICE

A strap, webbing or other device used for securing a wheelchair to the school bus, including all necessary buckles and other fasteners (S4.5).

APPENDIX C....Continued**C3 COMPLIANCE TEST EXECUTION****SEQUENCE FOR WHEELCHAIR SECUREMENT ANCHORAGE AND WHEELCHAIR OCCUPANT RESTRAINT ANCHORAGES TESTS.**

The test vehicle shall be subjected to the tests in the order shown below:

- A. Visual inspection
- B. Static load testing of wheelchair securement anchorages and wheelchair occupant restraint anchorages

VISUAL INSPECTION

The wheelchair securement anchorages and wheelchair occupant restraint anchorages are designed for forward seating wheelchair position. Each wheelchair location shall have not less than four wheelchair securement anchorages (Type A or C) -- two located in the front of the wheelchair and two in the rear. Type C anchorages may be used rearward of the wheelchair only. Each wheelchair location shall have not less than two wheelchair occupant pelvic and upper torso restraint anchorages (Type Bs, Cs, or combination). The pelvic belt may attach to but must not terminate at the wheelchair. Each wheelchair location shall have not less than one Type D anchorage. Record the number and type(s) of anchorages on Data Sheet A3.1. Wheelchair securement device incorporating webbing or a strap shall provide a means of adjustment to remove slack from the device. If webbing or a strap is not used, then the securement device shall provide means which limit movement of the wheelchair.

STATIC LOAD TESTING OF WHEELCHAIR SECUREMENT ANCHORAGES AND WHEELCHAIR OCCUPANT RESTRAINT ANCHORAGES

APPENDIX C....Continued**PREPARATION OF TEST VEHICLE AND EQUIPMENT**

- (1) The test equipment and its installation onto the vehicle and any modifications made to the vehicle in order to perform the test, shall not strengthen or weaken the vehicle structure in the vicinity of the anchorage to be tested, or interfere in any way with the proper execution of the test.
- (2) Connect, as a load transfer device, the wheelchair securement device or wheelchair occupant restraint device to the load cell. These devices will transfer the applied test loads to the anchorages to be tested. If this is not feasible, then a suitable load transfer device must be fabricated. This device must be capable of transferring the required test load, and must not alter the force application angle or direction, or introduce any additional loads or moments at the anchorage. **THE LOAD TRANSFER DEVICE MUST BE APPROVED BY THE COTR, AND THE ANCHORAGE MUST NOT BE MODIFIED IN ANY WAY.**
- (3) Connect the load application device to the load cell.
- (4) **NOTE: THE COTR MUST BE CONSULTED IN DETERMINING THE EXACT TEST ANGLES.**

FOR TYPE A ANCHORAGES

The load application device shall be positioned such that the angle of pull is not less than 30 degrees, but not more than 60 degrees, measured from the horizontal. In addition, the horizontal projection of the force direction shall be within a horizontal arc of ± 45 degrees relative to a longitudinal line which has its origin at the anchorage location and projects rearward for an anchorage whose wheelchair securement device is intended to secure the front of the wheelchair and forward for an anchorage whose wheelchair securement device is intended to secure the rear of the wheelchair (See Figure 1).

FOR TYPE B OR C ANCHORAGES

The load application device shall be positioned such that the angle of pull is not less than 45 degrees, but not more than 80 degrees, measured from the horizontal. In addition, the horizontal projection of the force direction shall be within a horizontal arc of ± 45 degrees relative to a longitudinal line which has its origin at the anchorage location and projects forward as shown in Figure 2.

APPENDIX C....Continued

WHEELCHAIR SECUREMENT ANCHORAGE (TYPE A) LOADING DIRECTION
(REAR ANCHORAGE SHOWN)

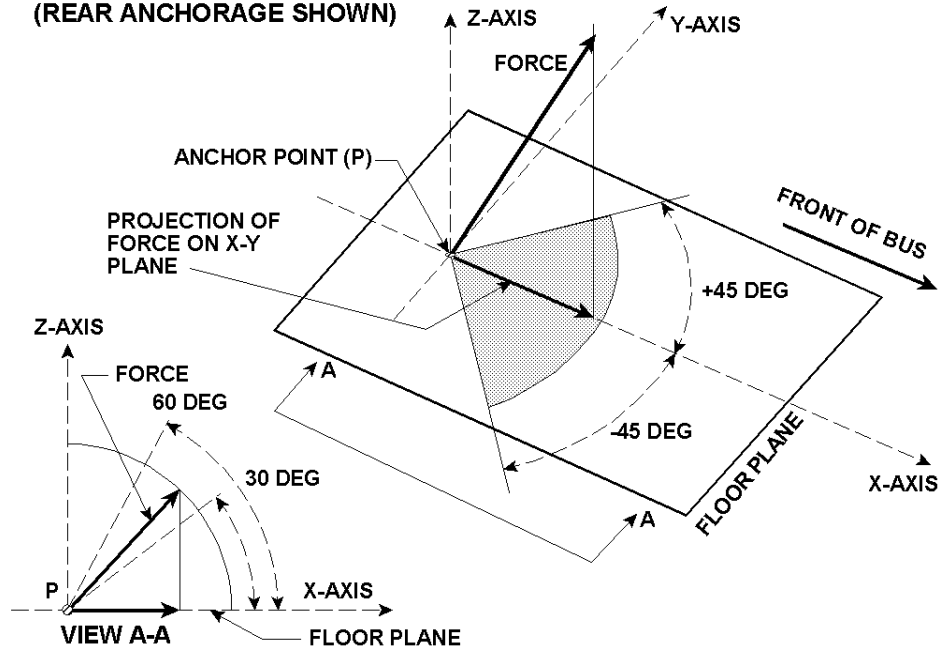

FIGURE 1

FOR TYPE D ANCHORAGES

The loading application device shall be positioned such that the angle of pull shall be applied at a vertical angle of not less than 0 degrees but no more than 40 degrees, below a horizontal plane which passes through the anchorage as shown in Figure 3.

- (5) Perform and record pretest zero and calibration settings on instrumentation prior to testing, and document for inclusion in the final report. Provide tolerance range indicators on the tracings, chart, or data paper, and provide tolerance range indicators on instruments so that if the test is video taped it shall be apparent that the test was conducted within the test procedure requirements. Identify each recording with date, time, vehicle, test technicians, NHTSA Number, chart speed, if applicable, FMVSS Number, X axis and Y axis names, units of measure and instrument settings. Record the serial numbers of equipment used for each specific load application location.

APPENDIX C....Continued

LOADING DIRECTION FOR PELVIC RESTRAINT ANCHORAGE (TYPE B),
AND PELVIC RESTRAINT ANCHORAGE AND WHEELCHAIR
SECUREMENT COMMON ANCHORAGE (TYPE C)

FIGURE 2

TEST PERFORMANCE

- (1) For Type A or B Anchorages

Apply a test force of 13,334 newtons. The force shall be applied at the onset rate of not more than 133,440 newtons per second. The 13,344 newtons force shall be attained in not more than 30 seconds, and shall be maintained for 10 seconds. When more than one wheelchair securement device share a common type A anchorage, or when more than one wheelchair occupant restraint shares a common Type B anchorage, the test force shall be 13,344 newtons multiplied by the number of securement devices or occupant restraints sharing that anchorage.

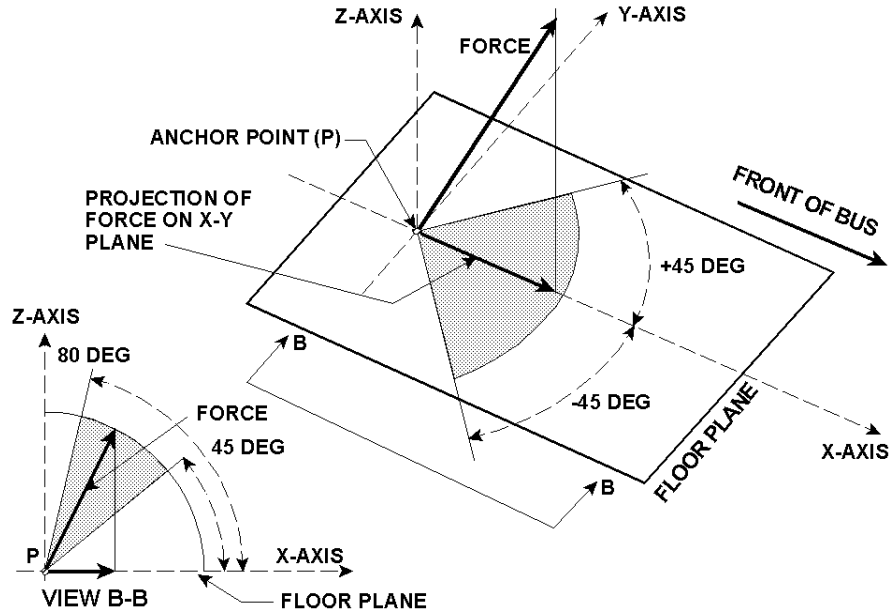
APPENDIX C....Continued

UPPER TORSO RESTRAINT ANCHORAGE (TYPE D) LOADING DIRECTION

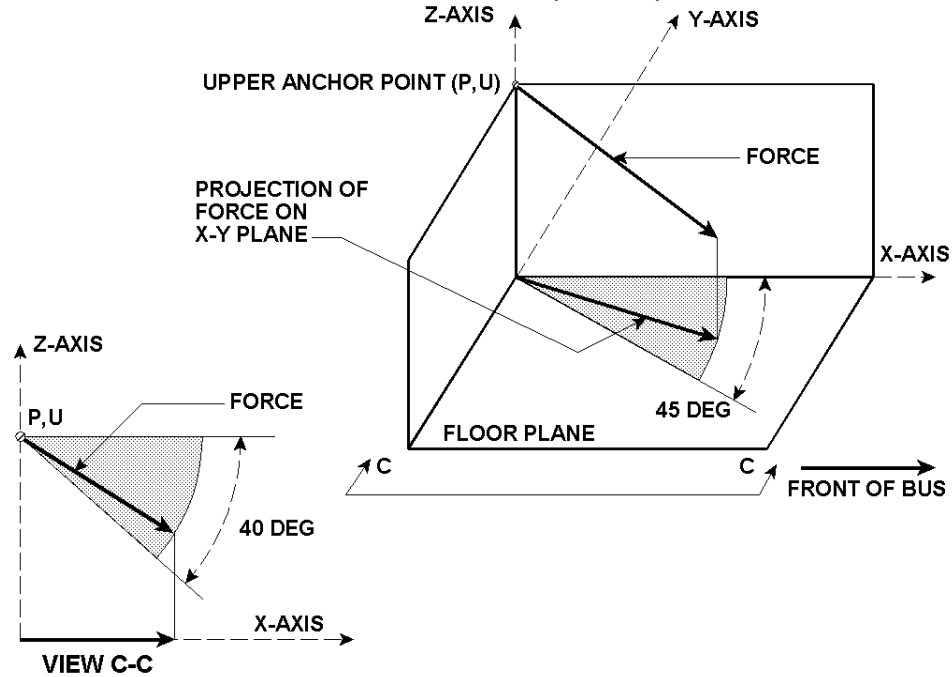

FIGURE 3

(2) For Type C Anchorages

Apply a test force of 13,344 newtons multiplied by the number of wheelchair securement device and occupant restraint that are common to that anchorage. The force shall be applied at the onset rate of not more than 133,440 newtons per second. The target test force shall be attained in not more than 30 seconds, and shall be maintained for 10 seconds.

(3) For Type D Anchorages

Apply a test force of 6,672 newtons. The force shall be applied at the onset rate of not more than 66,720 newtons per second. The 6,672 newtons force shall be attained in not more than 30 seconds, and shall be maintained for 10 seconds.

APPENDIX C....Continued

- (4) For each anchorage load application, the test force shall be adjusted to 5% of target load. While at this load level, photographs and measurements of the load application angles shall be taken. The load application angles shall be recorded on Data Sheet C1. The load shall then be increased to 100% of the target load. After holding the load for a minimum of 10 seconds (load application time from 5% of load can not exceed 30 seconds), the test load shall be released, anchorages inspected, and all post test photographs taken.
- (5) Perform and record post test zero and calibration checks.
- (6) Descriptions of test vehicle damage resulting from the anchorage loadings shall be recorded on the "Report of Vehicle Condition at the Completion of Testing" form and included in the final report. Permanent deformation or rupture of a wheelchair securement anchorage or wheelchair occupant restraint anchorage, or its surrounding area is not considered to be a failure, if the required test force is sustained for the specified time.
- (7) Where requirements are not specified, testing shall be performed using good engineering judgment.
- (8) Enter anchorage test data in Data Sheet C1.

APPENDIX C....Continued

5. The wheelchair location has at least one type D anchorage:

Yes ___ - Pass

No ___ - Fail

6. The wheelchair securement device has means to limit movement of the wheelchair:

Yes ___ - Pass

No ___ - Fail

APPENDIX C....Continued

Wheelchair Location	Anchorage Location	Anchorage Type	Required Load	Actual Max. Test Load	Pass/Fail	Comment
	LF					
	RF					
	LR					
	RR					
	Upper Torso					
	Other					
	LF					
	RF					
	LR					
	RR					
	Upper Torso					
	Other					
	LF					
	RF					
	LR					
	RR					
	Upper Torso					
	Other					
	LF					
	RF					
	LR					
	RR					
	Upper Torso					
	Other					

REFERENCES

SAE J826, Devices For Use In Defining and Measuring Vehicle Seating Accommodation

SAE J383, Motor Vehicle Seat Belt Anchorages -- Design Recommendations