

*[Note from NHTSA: The Acting Associate Administrator for Rulemaking signed the following document and we are submitting it for publication in the Federal Register. While we have taken steps to ensure the accuracy of this Internet version of the document, it is not the official version. Please refer to the official version in a forthcoming Federal Register publication. You can access the Federal Register at: [www.federalregister.gov](http://www.federalregister.gov)]*

**DEPARTMENT OF TRANSPORTATION**

**National Highway Traffic Safety Administration**

**49 CFR Part 571**

**Docket No. NHTSA-2014-0085**

**RIN 2127-AK96**

**Federal Motor Vehicle Safety Standards;**

**Bus Rollover Structural Integrity,**

**Motorcoach Safety Plan**

**AGENCY:** National Highway Traffic Safety Administration (NHTSA), Department of Transportation (DOT).

**ACTION:** Notice of proposed rulemaking (NPRM).

**SUMMARY:** NHTSA is issuing this NPRM to propose a new Federal motor vehicle safety standard to enhance the rollover structural integrity of certain types of large buses (generally, over-the-road buses (of any weight) and non-over-the-road buses with a gross vehicle weight rating (GVWR) greater than 11,793 kilograms (kg) (26,000 pounds (lb))). The agency is proposing performance requirements that new large buses of these types must meet in a test in which the vehicle is tipped over from an 800 millimeter (mm) raised platform onto a level ground surface. The performance requirements would ensure that these vehicles provide a sufficient level of survival space to restrained occupants in

rollover crashes. The performance requirements would also ensure that seats and overhead luggage racks remain secured and window glazing attached to its mounting during and after a rollover crash, and would ensure that emergency exits remain closed during the rollover crash and operable after the crash.

This NPRM is among the rulemakings issued pursuant to NHTSA's 2007 Approach to Motorcoach Safety and DOT's Departmental Motorcoach Safety Action Plan. In addition, establishing roof strength and crush resistance requirements, to the extent warranted under the National Traffic and Motor Vehicle Safety Act, would fulfill a statutory provision of the Motorcoach Enhanced Safety Act of 2012 (incorporated and passed as part of the Moving Ahead for Progress in the 21<sup>st</sup> Century Act).

**DATES:** Comments must be received on or before **[INSERT DATE 60 DAYS AFTER DATE OF PUBLICATION IN THE FEDERAL REGISTER]**.

**ADDRESSES:** You may submit comments to the docket number identified in the heading of this document by any of the following methods:

- Federal eRulemaking Portal: go to <http://www.regulations.gov>. Follow the online instructions for submitting comments.
- Mail: Docket Management Facility, M-30, U.S. Department of Transportation, West Building, Ground Floor, Rm. W12-140, 1200 New Jersey Avenue, S.E., Washington, D.C. 20590.
- Hand Delivery or Courier: West Building Ground Floor, Room W12-140, 1200 New Jersey Avenue, S.E., between 9 am and 5 pm Eastern Time, Monday through Friday, except Federal holidays.
- Fax: (202) 493-2251.

Regardless of how you submit your comments, please mention the docket number of this document.

You may also call the Docket at 202-366-9324.

Instructions: For detailed instructions on submitting comments and additional information on the rulemaking process, see the Public Participation heading of the Supplementary Information section of this document. Note that all comments received will be posted without change to <http://www.regulations.gov>, including any personal information provided.

Privacy Act: Please see the Privacy Act heading under Rulemaking Analyses and Notices.

#### **FOR FURTHER INFORMATION CONTACT:**

For non-legal issues, Ms. Shashi Kuppa, Office of Crashworthiness Standards (telephone: 202-366-3827) (fax: 202-493-2990). Ms. Kuppa's mailing address is National Highway Traffic Safety Administration, NVS-113, 1200 New Jersey Avenue, S.E., Washington, DC 20590.

For legal issues, Mr. Jesse Chang, Office of the Chief Counsel (telephone: 202-366-2992) (fax: 202-366-3820). Mr. Chang's mailing address is National Highway Traffic Safety Administration, NCC-112, 1200 New Jersey Avenue, S.E., Washington, DC 20590.

#### **SUPPLEMENTARY INFORMATION:**

##### **Table of Contents**

- I. Executive Summary
- II. Background
  - a. NHTSA's Statutory Authority
  - b. NHTSA's 2007 Approach to Motorcoach Safety
  - c. DOT's 2009 Task Force Action Plan

- d. NTSB Recommendations
- e. NHTSA's Seat Belt Final Rule
- III. Safety Need
  - a. FARS Data and Recent Crashes
  - b. Rollover and Ejection Statistics
- IV. NHTSA's Large Bus Rollover Structural Integrity Research
  - a. Findings of the FMVSS No. 220-Based Tests
  - b. Findings of the ECE R.66-Based Tests
- V. Proposed Requirements
  - a. Overview
  - b. Applicability
  - c. Test Procedure
  - d. Survival Space
  - e. Overhead Luggage Rack and Seat Retention
  - f. Emergency Exits
  - g. Side Window Glazing
- VI. Regulatory Alternatives
  - a. FMVSS No. 216
  - b. FMVSS No. 220
  - c. ECE R.66 Alternative Compliance Methods
  - d. Comments Requested on Alternative Levels of Stringency
- VII. Other Issues
  - a. Retrofitting
  - b. Lead Time
  - c. Additional MAP-21 Considerations
- VIII. Overview of Costs and Benefits
- IX. Regulatory Analyses
- X. Public Participation
- XI. Proposed Regulatory Text

## **I. Executive Summary**

This rulemaking is part of both NHTSA and DOT's continual effort to improve safety in motorcoaches and other types of large buses. In 2007, NHTSA published its Approach to Motorcoach Safety describing NHTSA's comprehensive strategy to improve

motorcoach safety.<sup>1</sup> The plan was developed to respond to several National Transportation Safety Board (NTSB) recommendations, and also to address several crashes that occurred after those recommendations were issued. In 2009, DOT issued a Departmental Motorcoach Safety Action Plan,<sup>2</sup> which outlined a Department-wide strategy to enhance motorcoach safety, addressing additional factors such as driver fatigue and operator maintenance issues.

NHTSA's Approach to Motorcoach Safety identified four specific areas where NHTSA could most effectively address open NTSB recommendations and potentially improve motorcoach safety. The four priority areas were: reducing the risk of passenger ejection from the motorcoach, improving rollover structural integrity, enhancing emergency evacuation, and upgrading fire safety.

NHTSA has published a final rule (RIN 2127-AK56) on the first area detailed in NHTSA's Approach to Motorcoach Safety, requiring seat belts for each passenger seating position in: (a) all new over-the-road buses<sup>3</sup>; and (b) in new buses other than over-the-road buses, with a GVWR greater than 11,793 kg (26,000 lb).<sup>4</sup> Today's NPRM builds on the seat belt final rule by proposing to require those buses to meet increased structural integrity and other requirements to protect both restrained and unrestrained occupants in rollover crashes.

---

<sup>1</sup> See Docket No. NHTSA-2007-28793, NHTSA's Approach to Motorcoach Safety. In NHTSA's plan, "motorcoach" referred to inter-city transport buses.

<sup>2</sup> An update to the 2009 plan was published in December 2012, <http://www.fmcsa.dot.gov/safety-security/pcs/Motorcoach-Safety-Action-Plan.aspx>.

<sup>3</sup> An over-the-road bus is a bus characterized by an elevated passenger deck located over a baggage compartment.

<sup>4</sup> Some buses are excluded from this latter category, such as transit and school buses.

On July 6, 2012, the President signed the “Moving Ahead for Progress in the 21<sup>st</sup> Century Act” (MAP-21).<sup>5</sup> MAP-21 incorporates the “Motorcoach Enhanced Safety Act of 2012” (Motorcoach Enhanced Safety Act) in Subtitle G (§§ 32701 et seq.) Among other matters, the Motorcoach Enhanced Safety Act requires DOT to “establish improved roof and roof support standards for motorcoaches that substantially improve the resistance of motorcoach roofs to deformation and intrusion to prevent serious occupant injury in rollover crashes involving motorcoaches” if such standards “meet the requirements and considerations set forth in subsections (a) and (b) of section 30111 of title 49, United States Code.”<sup>6</sup> In addition, MAP-21<sup>7</sup> directs DOT to consider “portal improvements to prevent partial and complete ejection of motorcoach passengers, including children.” Under MAP-21, “motorcoach” means an over-the-road bus, but does not include a bus used in public transportation provided by, or on behalf of, a public transportation agency, or a school bus.

We have issued this NPRM in furtherance of NHTSA’s goal to enhance the safety of all heavy buses used in intercity bus transportation, including over-the-road buses, which were the focus of the Motorcoach Enhanced Safety Act of MAP-21. Similar to the seat belt rule, we are not proposing that this standard apply to school buses and urban transit buses.

Transportation by over-the-road buses (and other similar large buses) is an overall safe form of transportation. Over the ten year period between 2000 and 2009, there were 87 fatal crashes involving the large bus types covered by today’s proposed rule. These crashes resulted in 209 occupant fatalities (168 passenger and 41 driver fatalities).

---

<sup>5</sup> Moving Ahead for Progress in the 21<sup>st</sup> Century Act, Pub. L. No. 112-141.

<sup>6</sup> See MAP-21, §§ 32703(b)-(b)(1).

<sup>7</sup> *Id.*, §§ 32703(b)(2).

During this period, on average, 21 fatalities have occurred annually to occupants of these buses in crashes. Annually 17 of these fatalities were passengers and 4 were drivers.

Nonetheless, given the high occupancy of these vehicles, a significant number of fatal or serious injuries can occur in a single crash. NHTSA tentatively believes that standards improving structural integrity and thereby side window glazing retention, issued pursuant to §§ 32703(b)-(b)(2) of MAP-21 and the National Traffic and Motor Vehicle Safety Act (“Motor Vehicle Safety Act”), would meet the need for safety. Among the 87 fatal crashes (involving the bus types covered by today’s proposal) that occurred from 2000-2009, data from NHTSA’s Fatality Analysis Reporting System (FARS) indicate that 32 were rollover crashes resulting in 114 fatalities. While fatal rollover crashes were only one-third of all fatal crashes involving these bus types, they represent more than half of all the occupant fatalities. Further, approximately two-thirds of the rollover crash fatalities were attributable to occupant ejections.

In developing today’s NPRM, the agency turned to United Nations Economic Commission for Europe Regulation 66 (ECE R.66).<sup>8</sup> Today’s NPRM proposes a test for rollover structural integrity based on the complete vehicle rollover test of ECE R.66. We also examined the school bus roof crush standard set forth in Federal Motor Vehicle Safety Standard (FMVSS) No. 220, “School bus rollover protection,” but chose to base our new standard on ECE R.66’s complete vehicle test because the latter appears to more closely simulate a real-world rollover crash involving the large bus types that are associated with the highest crash risk. Further, an ECE R.66-based test enables us to better evaluate particular aspects of performance that are pertinent for safety of these

---

<sup>8</sup> Uniform Technical Prescriptions Concerning the Approval of Large Passenger Vehicles with Regard to the Strength of their Superstructure, ECE R.66, February 2006, <http://live.unece.org/fileadmin/DAM/trans/main/wp29/wp29regs/r066r1e.pdf>.

types of buses (e.g., the affixing of side glazing panels—an area of concern of MAP-21—and attachment of overhead luggage racks). Using a procedure based on ECE R.66 also furthers NHTSA's efforts to harmonize with international standards when feasible.

This NPRM proposes performance requirements that the buses must meet when tested by NHTSA using an ECE R.66-based test. The vehicle is placed on a tilting platform that is 800 mm above a smooth and level concrete surface. One side of the tilting platform along the length of the vehicle is raised at a steady rate of not more than 5 degrees/second until the vehicle becomes unstable, rolls off the platform, and impacts the concrete surface below.

The rollover structural integrity test is illustrated below in Figure 1.



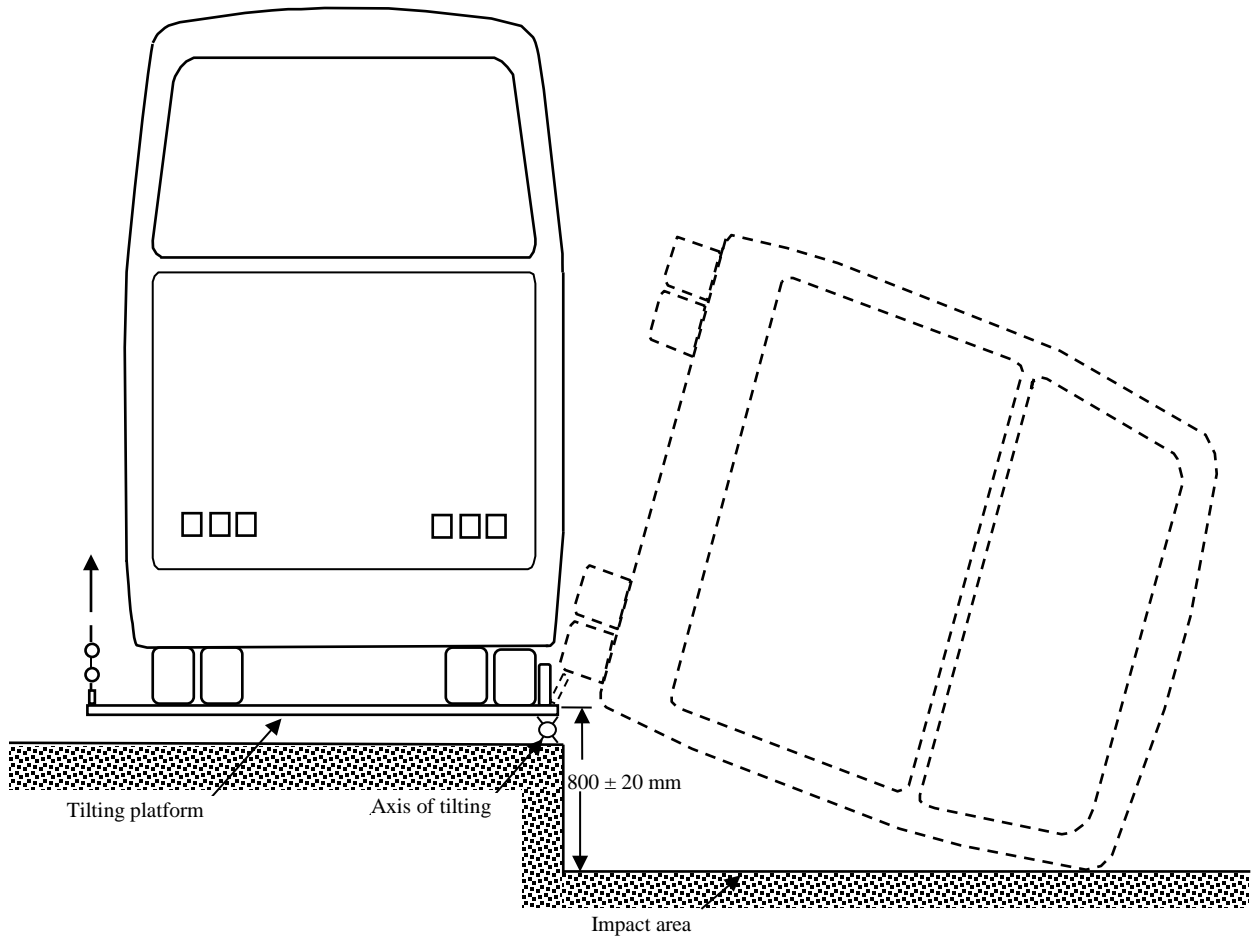

**Figure 1: Vehicle on Tilting Platform**

The following are the main proposed performance requirements that buses covered by this proposed rule must meet when subjected to the rollover structural integrity test:

- (1) intrusion into the “survival space,” demarcated in the vehicle interior, by any part of the vehicle outside the survival space is prohibited;
- (2) each anchorage of the seats and overhead luggage racks must not completely separate from its mounting structure;
- (3) emergency exits must remain shut during the test and must be operable in the manner required under FMVSS No. 217 after the test; and

(4) each side window glazing opposite the impacted side of the vehicle must remain attached to its mounting such that there is no opening that will allow the passage of a 102 mm diameter sphere.

We believe these proposed requirements would provide reasonable and needed improvements to the types of buses with the greatest safety risk in rollovers. They supplement the agency's final rule on passenger seat belts. With passengers more likely to be retained in the bus interior as a result of the agency's seat belt final rule, today's NPRM improves the protective attributes of the occupant compartment in which they are retained.

The proposed requirements for maintaining the survival space and ensuring that seats, overhead luggage racks, and window glazing remain attached to their mounting structures would set a minimum level of structural integrity for these buses, to help prevent dangerous structural intrusions into the occupant survival space. The proposed requirement that emergency exits remain closed during the rollover structural integrity test and operable after the test is to increase the likelihood that emergency exits do not become ejection portals during rollover crashes. The requirement also helps ensure that the emergency exits remain an effective means of egress after the crash.

NHTSA believes that this rulemaking would be cost beneficial.<sup>9</sup>

The agency estimates the annual cost of this proposed rule to be between \$5.28 million and \$13.26 million (see Table 1 below). The countermeasures may include stronger roof structure, support pillars, and side walls, shock resistant latches for

---

<sup>9</sup> NHTSA has developed a Preliminary Regulatory Evaluation (PRE) that discusses issues relating to the potential costs, benefits and other impacts of this regulatory action. The PRE is available in the docket for this NPRM and may be obtained by downloading it or by contacting Docket Management at the address or telephone number provided at the beginning of this document.

emergency exits, stronger seat and overhead luggage rack anchorages, and improved window mounting, resulting in material costs for each bus covered under today's proposed rule ranging from \$282 to \$507. We estimate the total weight increase will range from 564 to 1,114 pounds (lb) for each of these buses and cost an additional \$2,118 to \$5,523 in fuel per vehicle over the lifetime of the vehicle.

Beyond the benefits attributable to the agency's final rule on seat belts and a potential final rule on electronic stability control (ESC) that also may apply to this universe of vehicles,<sup>10</sup> we estimate that requiring new buses of the aforementioned types to meet the proposed performance criteria would save approximately 2 lives annually. In addition, we expect that the proposed rule would reduce the number of seriously injured occupants by approximately 4 annually. Thus, we estimate that approximately 3.1 equivalent lives are saved annually if 15 percent of occupants use seat belts, and approximately 2.3 equivalent lives are saved annually (undiscounted) if 84 percent of occupants use seat belts (see Table 2 below).

The cost per equivalent life saved is estimated to be \$2.09 million to \$4.72 million when belt use is estimated to be 15 percent, and \$2.91 million to \$6.42 million when belt use is estimated to be 84 percent (see Table 3 below). The net cost/benefit impact ranges from a net benefit of \$9.47 million to \$19.35 million if seat belt usage is 15 percent. If the seat belt usage rate is 84 percent, the estimated net cost/benefit impact ranges from a net benefit of \$4.69 million to a net benefit of \$13.06 million (see Table 4 below). While the cost and benefits of this rule will vary depending on the material/fuel costs per

---

<sup>10</sup>An ESC rulemaking for the buses is also included in MAP-21. The statute directs us to consider requiring motorcoaches to be equipped with stability enhancing technology, such as ESC, to reduce the number and frequency of rollover crashes. See § 32703(b)(3).

vehicle and on the belt use rate, all the available information indicate that this proposed rule—if made final—would be cost beneficial.

**Table 1: Estimated Annual Costs  
(2010 Dollars)**

<b>Potential Costs</b>	
Material Costs Per Vehicle	\$282 to \$507
Material Costs, Total New Fleet	\$0.6 million to \$1.1 million
Fuel Costs per Vehicle @ 3%	\$2,814 to \$5,523
Fuel Costs per Vehicle @ 7%	\$2,118 to \$4,156
Fuel Costs, Total New Fleet	\$4.7 million to \$12.2 million
<b>Total Annual Cost</b>	<b>\$5.3 million to \$13.3 million</b>

**Table 2: Estimated Annual Benefits  
(Undiscounted Equivalent Lives Saved)**

15 percent belt usage	3.1
84 percent belt usage	2.3

**Table 3: Cost per Equivalent Life Saved  
(Across 3% and 7% Discount, 2010 Dollars)**

15 percent belt usage	\$2.09 million to \$4.72 million
84 percent belt usage	\$2.91 million to \$6.42 million

**Table 4: Annualized Costs and Benefits  
In Millions (M) of 2010 Dollars**

	<b>Annual Costs</b>	<b>Annual Benefits</b>	<b>Net Benefits</b>
15% belt usage			
3% Discount Rate	\$6.81 M - \$13.26 M	\$26.16 M	\$12.9 M - \$19.35 M
7% Discount Rate	\$5.28 M - \$10.26 M	\$19.73 M	\$9.47 M - \$14.45 M
84% belt usage			
3% Discount Rate	\$6.81 M - \$13.26 M	\$19.87 M	\$6.61 M - \$13.06 M
7% Discount Rate	\$5.28 M - \$10.26 M	\$14.95 M	\$4.69 M - \$9.67 M

NHTSA has considered retrofit requirements. Based on our tests of older buses, the agency believes that major structural changes to the vehicle's entire sidewall and roof structure would be needed for some existing buses (that are of the type covered by this rule) to meet the rollover structural integrity requirements proposed in today's NPRM. Such structural changes are likely to be cost-prohibitive, making retrofitting for rollover structural integrity quite impractical. Thus, the agency has tentatively not included roof structure retrofitting requirements for existing vehicles in today's proposal.

However, today's NPRM proposes requirements for emergency exit integrity and operability and side window glazing retention through enhanced structural integrity, aspects of performance included in § 32703(b)(2) of MAP-21. Section 32703(e)(2)(A) of MAP-21 states that "the Secretary may assess the feasibility, benefits, and costs with respect to the application of any requirement established under [§ 32703(b)(2)] to motorcoaches manufactured before the date on which the requirement applies to new motorcoaches." Subsection (e) states that the Secretary shall submit a report on the assessment to Congress not later than July 2014. Thus, the agency is requesting comments on the feasibility, benefits, and costs of any potential requirement to retrofit existing buses with stronger emergency exit mechanisms and enhanced structural integrity to increase side window glazing retention to afford a similar level of anti-ejection protection for passengers riding in existing buses.

## **II. Background**

Each year, the motorcoach industry transports millions of people for long and short distance travel, tours, school field trips, commuter, and entertainment-related trips.

According to the 2008 Motorcoach Census,<sup>11</sup> there were 3,432 over-the-road bus carriers in the United States and Canada in 2007. These carriers operated over 33,536 over-the-road buses,<sup>12</sup> logged 751 million trips made by passengers, and traveled over 1.8 billion miles yearly. The services provided by over-the-road buses in 2007 included charter services (46.4 percent of the miles driven), moving people between cities or between cities and rural areas (26.5 percent of the miles driven), transporting people between home and work (10.3 percent of the miles driven), and shuttle services to and from the airport (3.4 percent of the miles driven). In 2007, each over-the-road bus was driven an average of 54,000 miles.

Over the ten year period between 2000 and 2009, there were 45 fatal crashes of cross-country/intercity buses resulting in 134 occupant fatalities<sup>13</sup> according to the FARS data<sup>14</sup> collected by the agency. During this period, on average, 13 fatalities (11 passengers and 2 drivers) have occurred annually to occupants of cross-country/intercity buses. This field and market data suggest that over-the-road (cross-country/intercity) bus transportation overall is a relatively safe form of transportation.

---

<sup>11</sup> The “2008 Motorcoach Census,” funded by the American Bus Association (ABA), defines a motorcoach as an over-the-road bus, designed for long-distance transportation of passengers, characterized by integral construction, and with an elevated passenger deck located over a baggage compartment. *See* “Motorcoach Census 2008, A Benchmarking Study of the Size and Activity of the Motorcoach Industry in the United States and Canada in 2007.” Paul Bourquin, Economist and Industry Analyst, December 18, 2008. The buses included in the 2008 Motorcoach Census are over-the-road buses that are at least 35 feet in length and have a capacity of more than 30 passengers. Traditionally, these over-the-road buses are considered to be motorcoaches. We note that this rule would apply to a larger set of vehicles than those within the ABA’s definition of motorcoach, and therefore the statistics from the 2008 Motorcoach Census presented in this section are only applicable to over-the-road buses.

<sup>12</sup> The 2008 Motorcoach Census defines motorcoaches to include a smaller set of vehicles than those covered by this NPRM. Thus, we have used the term “over-the-road buses” to describe the set of vehicles referenced by the 2008 Motorcoach Census.

<sup>13</sup> There was one cross-country/intercity bus fire in 2005 in Wilmer, Texas where 23 bus occupants died. The 134 occupant fatalities in cross-country/intercity buses does not include the 23 fatalities from the bus fire since it did not occur as a result of a bus crash or rollover.

<sup>14</sup> The FARS database categorizes the vehicle body type of over-the-road buses as cross-country/intercity buses.

However, given the high occupancy of over-the-road buses (and the other large buses considered in today's proposed rule) and the speed at which they travel, a single crash can result in a significant number of fatal or serious injuries. Therefore, in this NPRM, the agency is proposing to enhance the safety of these vehicles by improving their crashworthiness relative to crush resistance, structural integrity, and reducing portal openings during rollover crashes.

**a. NHTSA's Statutory Authority**

NHTSA is proposing today's NPRM pursuant to its authority under the Motor Vehicle Safety Act and the relevant provisions of MAP-21.

National Traffic and Motor Vehicle Safety Act

Under 49 U.S.C. Chapter 301, Motor Vehicle Safety (49 U.S.C. 30101 et seq.), the Secretary of Transportation is responsible for prescribing motor vehicle safety standards that are practicable, meet the need for motor vehicle safety, and are stated in objective terms. "Motor vehicle safety" is defined in the Motor Vehicle Safety Act as "the performance of a motor vehicle or motor vehicle equipment in a way that protects the public against unreasonable risk of accidents occurring because of the design, construction, or performance of a motor vehicle, and against unreasonable risk of death or injury in an accident, and includes nonoperational safety of a motor vehicle." "Motor vehicle safety standard" means a minimum performance standard for motor vehicles or motor vehicle equipment. When prescribing such standards, the Secretary must consider all relevant, available motor vehicle safety information. The Secretary must also consider whether a proposed standard is reasonable, practicable, and appropriate for the types of motor vehicles or motor vehicle equipment for which it is prescribed and the extent to which the standard will further the statutory purpose of reducing traffic

accidents and associated deaths. The responsibility for promulgation of Federal motor vehicle safety standards is delegated to NHTSA.<sup>15, 16</sup> In making the proposals in today's NPRM, the agency carefully considered all the aforementioned statutory requirements.

Motorcoach Enhanced Safety Act of 2012 (Incorporated in MAP-21)

On July 6, 2012, President Obama signed MAP-21, which incorporated the "Motorcoach Enhanced Safety Act of 2012" into Subtitle G.<sup>17</sup> Section 32703(b) of MAP-21 requires the Secretary to prescribe standards that would address certain aspects of motorcoach crash performance within two years if the Secretary determines that the standards would meet the requirements and considerations of §§ 30111(a) and (b) of the Motor Vehicle Safety Act.<sup>18</sup> There are two subsections of § 32703(b) that are particularly relevant to this NPRM. Subsection (b)(1) specifies that the Secretary is to establish improved roof and roof support standards that "substantially improve the resistance of motorcoach roofs to deformation and intrusion to prevent serious occupant injury in rollover crashes involving motorcoaches." Subsection (b)(2) directs the Secretary to "consider advanced glazing standards for each motorcoach portal and [to] consider other portal improvements to prevent partial and complete ejection of motorcoach passengers, including children."<sup>19</sup>

---

<sup>15</sup> See 49 C.F.R Part 1.95.

<sup>16</sup> The Secretary also delegated to NHTSA the authority set out for Section 101(f) of Public Law 106-159 to carry out, in coordination with the Federal Motor Carrier Safety Administrator, the authority vested in the Secretary by subchapter 311 and section 31502 of title 49, U.S.C., to promulgate safety standards for commercial motor vehicles and equipment subsequent to initial manufacture when the standards are based upon and similar to a Federal Motor Vehicle Safety Standard promulgated, either simultaneously or previously, under chapter 301 of title 49, U.S.C.

<sup>17</sup> See Moving Ahead for Progress in the 21<sup>st</sup> Century Act, Pub. L. No. 112-141 (Jul. 6, 2012).

<sup>18</sup> See *id.* at § 32703(b).

<sup>19</sup> While today's NPRM is mainly aimed at addressing the rollover structural integrity of specific large bus types, the proposed rule also addresses some of the safety risks associated with occupant ejection through side window glazing retention and emergency exit requirements. Thus, both subsection (b)(1) and subsection (b)(2) are relevant to this notice.



MAP-21 contains various other provisions that are relevant to this rulemaking. Section 32702 states that “motorcoach” has the meaning given to the term “over-the-road bus” in section 3038(a)(3) of the Transportation Equity Act for the 21st Century (TEA-21).<sup>20</sup> Section 3038(a)(3) of TEA-21 (*see* 49 U.S.C. 5310 note) defines “over-the-road bus” as “a bus characterized by an elevated passenger deck located over a baggage compartment.” However, § 32702 of MAP-21 excludes transit buses and school buses from the “motorcoach” definition.<sup>21</sup>

MAP-21 further directs the Secretary to apply any regulation prescribed in accordance with § 32703(b) (and several other subsections) to all motorcoaches manufactured more than 3 years after the date on which the regulation is published.<sup>22</sup> In addition, the Secretary may assess the feasibility, benefits, and costs of applying any requirement established under § 32703 (b)(2) to “motorcoaches manufactured before the date on which the requirement applies to new motorcoaches” (retrofit).<sup>23</sup> Finally, MAP-21 also authorizes the Secretary to combine the required rulemaking actions as the Secretary deems appropriate.<sup>24</sup>

#### **b. NHTSA’s 2007 Approach to Motorcoach Safety**

In 2007, NHTSA undertook a comprehensive review of motorcoach safety issues and the course of action that the agency could pursue to address them. The agency considered various prevention, mitigation, and evacuation approaches in developing the course of action. Many considerations were factored into determining the priorities, including: cost and duration of testing, development, and analysis required; likelihood

---

<sup>20</sup> *See* Moving Ahead for Progress in the 21<sup>st</sup> Century Act, Pub. L. No. 112-141, § 32702(6).

<sup>21</sup> *See id.* at § 32702(6)(A)-(B).

<sup>22</sup> *See id.* at § 32703(e)(1).

<sup>23</sup> *See id.* at § 32703(e)(2). “Retrofit Assessment for Existing Motorcoaches.”

<sup>24</sup> *See id.* at § 32706.

that the effort would lead to the desired and successful conclusion; target population and possible benefits that might be realized; and anticipated cost of implementing the ensuing requirements into the motorcoach fleet.

The result was NHTSA's 2007 plan, NHTSA's Approach to Motorcoach Safety (Docket No. NHTSA-2007-28793-001), in which we identified the following areas as the highest priorities for possible near term regulatory action to enhance motorcoach safety: (1) passenger ejection; (2) rollover structural integrity; (3) emergency egress; and (4) fire safety.

For passenger ejection (action (1) above), we pursued the incorporation of passenger seat belts as the most effective and expeditious way to mitigate ejection. The agency's seat belt rulemaking, discussed further below, began NHTSA's implementation of our Motorcoach Safety Plan. Today's document advances the implementation of the plan.

#### **c. DOT's 2009 Task Force Action Plan**

In 2009, DOT issued a Departmental Motorcoach Safety Action Plan, which outlined a Department-wide strategy to enhance motorcoach safety.<sup>25</sup> An update of the plan was issued on December 2012.<sup>26</sup> In addition to the four priority action items specified in NHTSA's 2007 plan, the 2009 DOT plan, and the 2012 updated plan identified additional factors for enhancing motorcoach safety, such as electronic stability control systems (ESC), event data recorders (EDRs), and driver fatigue and operator maintenance issues. Various DOT agencies are working on the motorcoach safety initiatives related to their administrations.

---

<sup>25</sup> [http://www.fmcsa.dot.gov/documents/safety-security/MotorcoachSafetyActionPlan\\_finalreport-508.pdf](http://www.fmcsa.dot.gov/documents/safety-security/MotorcoachSafetyActionPlan_finalreport-508.pdf)

<sup>26</sup> <http://www.fmcsa.dot.gov/safety-security/pcs/Motorcoach-Safety-Action-Plan.aspx>

#### **d. NTSB Recommendations**

As a part of its motorcoach crash investigations, NTSB has issued recommendations to NHTSA relating to actions that NTSB believes could improve motorcoach safety. The following NTSB recommendations related to motorcoach structural integrity pertain to this NPRM.

In an NTSB Highway Special Investigation Report (1999), *Bus Crashworthiness Issues*,<sup>27</sup> NTSB cited an October 1971 rollover of a 1970 Motor Coach Industries (MCI) bus as justification for the following recommendations:

“H-99-50 (MW): In 2 years, issue performance standards for motorcoach roof strength that provide maximum survival space for all seating positions and that take into account current typical motorcoach window dimensions.”

“H-99-51: Once performance standards have been developed for motorcoach roof strength, require newly manufactured motorcoaches to meet those standards.”

In November 2009, after investigating an August 2008 Sherman, Texas bus crash,<sup>28</sup> the NTSB issued two new safety recommendations. In this rollover crash, the failure of the overhead luggage rack on the vehicle impeded passenger egress and rescue efforts. Thus, NTSB stated that the Sherman accident and NHTSA’s motorcoach testing indicate that the lack of standards for overhead luggage racks on motorcoaches leaves passengers at risk of serious injury from interaction with overhead luggage racks in a crash and made the following recommendations:

---

<sup>27</sup> National Transportation Safety Board. 1999, *Bus Crashworthiness Issues*. Highway Special Investigation Report NTSB/SIR-99/04. Washington, DC.

<sup>28</sup> NTSB/HAR-09/02 PB2009-916202; Motorcoach Run-Off-the-Bridge and Rollover Sherman, Texas August 8, 2008; October 2009; <http://www.nts.gov/doclib/reports/2009/HAR0902.pdf>.

“H-09-23: Develop performance standards for newly manufactured motorcoaches to require that overhead luggage racks remain anchored during an accident sequence.”

“H-09-24: Develop performance standards for newly manufactured motorcoaches that prevent head and neck injuries from overhead luggage racks.”

In June 2010, after investigating a 2009 motorcoach rollover crash in Dolan Springs, the NTSB issued two additional recommendations:

“H-10-03: In your rulemaking to improve motorcoach roof strength, occupant protection, and window glazing standards, include all buses with a gross vehicle weight rating above 10,000 pounds, other than school buses.”

“H-10-04: Develop performance standards for all newly manufactured buses with a gross vehicle weight rating above 10,000 pounds to require that overhead luggage racks are constructed and installed to prevent head and neck injuries and remain anchored during an accident sequence.”

**e. NHTSA’s Seat Belt Final Rule**

Completing the first initiative of NHTSA’s 2007 “NHTSA’s Approach to Motorcoach Safety” plan and one of the principal undertakings of DOT’s 2009 Motorcoach Safety Action Plan, and fulfilling a statutory mandate of the Motorcoach Enhanced Safety Act, NHTSA issued a final rule amending FMVSS No. 208, “Occupant crash protection.” The final rule required lap/shoulder seat belts for each passenger seating position in: (a) all new over-the-road buses; and (b) in new buses other than over-the-road buses, with a GVWR greater than 11,793 kg (26,000 lb).<sup>29</sup> (The notice of

---

<sup>29</sup> Some buses are excluded from this latter category, such as transit buses, school buses, and buses with perimeter-seating.

proposed rulemaking preceding the final rule called buses with GVWR greater than 11,793 kg (26,000 lb) “motorcoaches.”)

NHTSA’s safety research on seat belts in large buses (greater than 11,793 kg (26,000 lb) GVWR) completed in 2009, showed that the installation of lap/shoulder belts on the vehicles is practicable and effective and could reduce the risk of fatal injuries in rollover crashes by 77 percent, primarily by preventing occupant ejection. Lap/shoulder belts are also highly effective in preventing fatalities and serious injuries in frontal crashes, and will enhance protection in side crashes in the affected buses. By requiring passenger lap/shoulder seat belts on (a) new over-the-road buses, and (b) new buses, other than over the road buses, with a GVWR greater than 11,793 kg (26,000 lb), the final rule significantly reduces the risk of fatality and serious injury in frontal crashes and the risk of occupant ejection in rollovers, thus considerably enhancing the safety of these vehicles.

### **III. Safety Need**

The rulemakings that are being conducted pursuant to the requirements of the Motor Vehicle Safety Act and MAP-21, and as part of NHTSA’s Approach to Motorcoach Safety and the DOT Motorcoach Safety Action Plan, explore whether there are unreasonable safety risks associated with motorcoach transportation. If there are such risks, we explore whether those safety risks can be reasonably reduced by having minimum levels of performance specified for crashworthiness and crash avoidance standards, such as a standard for rollover structural integrity.

NHTSA found in the seat belt final rule that, generally, a significant majority of fatalities are attributable to rollovers. Because more than three-quarters of rollover fatalities are attributable to ejections, NHTSA issued a seat belt requirement to mitigate

those ejections. For purposes of today's proposal, we believe that, hand-in-hand with that seat belt proposal, there is a need to ensure enhanced structural integrity of the interior of these buses, to better protect the restrained occupants who, due to the belts, will be retained in the bus interior. Moreover, independent of a seat belt requirement, we believe that more can be done to improve the vehicle structure to reduce the likelihood of ejection of occupants who may not be restrained at the time of the crash. For instance, emergency exits should not open during a rollover crash (an open emergency exit forms a portal through which occupants could be ejected). Today's NPRM proposes requirements to meet these objectives.

**a. FARS Data and Recent Crashes**

To determine the types of vehicles that should be covered by the rulemakings conducted pursuant to the Motor Vehicle Safety Act and MAP-21 and as part of the NHTSA's Approach to Motorcoach Safety plan and the DOT Motorcoach Safety Action Plan, the agency examined FARS data files to gain a better understanding of fatal crashes involving over-the-road buses and other bus types.<sup>30</sup> FARS contains data on a census of fatal traffic crashes within the 50 States, the District of Columbia, and Puerto Rico. To be included in FARS, a crash must involve a motor vehicle traveling on a traffic way customarily open to the public, and must result in the death of an occupant of a vehicle or a non-occupant within 30 days of the crash.

For the seat belt rulemaking and other "motorcoach" rulemakings, we analyzed 10 years of FARS data to assess what type of vehicle should be covered by NHTSA's motorcoach safety plan initiatives. We analyzed FARS data of high-occupancy vehicles

---

<sup>30</sup> Previous discussions of the FARS data is set forth in the seat belt final rule, and in the DOT 2009 Motorcoach Action Plan, <http://www.nhtsa.gov/staticfiles/DOT/NHTSA/reports/HS811177.pdf>.

(buses) that are in fatal crashes. FARS data for fatalities of occupants in high occupancy vehicles (buses with a GVWR greater than 4,536 kg (10,000 lb), other than school buses and transit buses) over 10 years show that 83 percent of the occupant fatalities were in buses with a GVWR greater than 11,793 kg (26,000 lb). Based on these data, NHTSA determined that the vehicles of significance are those with a GVWR of greater than 11,793 kg (26,000 lb). These buses appear to have a higher risk of involvement in fatal crashes involving passenger fatalities than buses with a GVWR of 11,793 kg (26,000 lb) or less.

For the seat belt final rule and for purposes of today's NPRM, the agency analyzed FARS data for vehicles coded in FARS as "cross-country/intercity buses," "other buses," and "unknown buses."<sup>31</sup> Among these buses (cross-country/intercity buses, other buses, unknown buses) with a GVWR greater than 11,793 kg (26,000 lb), there were a total of 209 occupant fatalities<sup>32</sup> in crashes during the 10-year period between 2000-2009. This number includes 134 occupant fatalities in cross-country/intercity buses, 47 in other buses, and 28 in unknown buses (see Figure 1 and Table 5 below). In contrast, with regard to buses with a GVWR less than 11,793 kg (26,000 lb), there were a total of 44 fatalities in cross-country/intercity buses, other buses, and unknown buses with a GVWR of 11,793 kg (26,000 lb) or less in the 2000-2009 FARS data files. This is approximately one-fifth of the fatalities in such buses with a GVWR greater than 11,793 kg (26,000 lb).

---

<sup>31</sup> The FARS database has five bus body type categories: (1) cross-country/intercity bus, (2) transit bus, (3) school bus, (4) other bus, and (5) unknown bus. Transit bus and school bus body types were excluded from the analysis because they are easily recognized and categorized as such by crash investigators and those coding the FARS data. Thus, those vehicles are unlikely to be miscoded as other buses.

<sup>32</sup> There were 232 occupant fatalities in the large bus types considered in today's NPRM during this 10-year period. However, 23 fatalities occurred due to a fire (Wilmer, Texas bus fire) and were not related to a crash event and therefore are not included in the fatality count resulting from crashes.

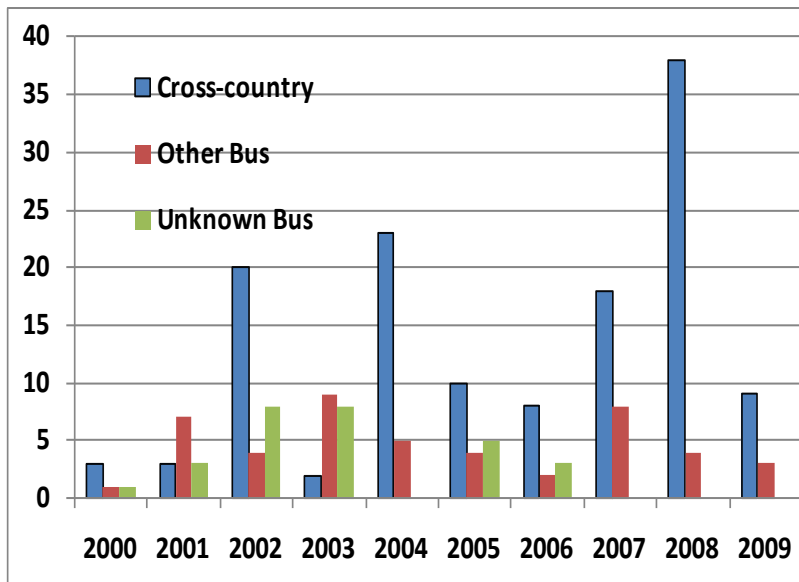

**Figure 1: Number of bus occupant fatalities in crashes involving cross-country, other, and unknown buses with a GVWR > 11,793 kg (26,000 lb) except for transit and school buses (categorized by bus body type). (FARS 2000-2009 data files.)**

**Table 5: Number of bus occupant fatalities in crashes by bus body type, GVWR, and occupant type. FARS 2000-2009 data files.**

	Bus Body Type							
	Cross-Country		Other		Unknown		Total	
GVWR (lb)	Driver	Pass	Driver	Pass	Driver	Pass	Driver	Pass
10,000-26,000	0	2	5	26	2	7	7	35
>26,000	22	112	11	36	8	20	41	168

Among the 209 occupant fatalities in the 10-year period, the FARS data show that 168 (80 percent) were passengers, and 41 (20 percent) were drivers. In addition, the data show that 64 percent of the fatalities were in cross-country/intercity buses and 36 percent were in the other bus and unknown bus categories (see Table 5 above).

As shown in Figure 1, fatalities in certain years are significantly higher than average. There were more than 20 occupant fatalities in 2002, 2004, 2007, and 2008 in



crashes involving these vehicles. We note that such increases in fatality statistics were often attributable to a small number of serious crashes during that year which caused a large number of fatalities.

For example, the majority of fatalities in 2004 resulted from a crash in Arkansas, which involved a bus hitting a highway signpost and subsequently rolling over. The rollover and partial detachment of the roof resulted in the ejection of all 30 occupants. This crash resulted in 15 fatalities, including the driver. All 14 passengers who died in this crash were ejected.

The 42 passenger fatalities in 2008 were mainly a result of 3 separate crashes. The first event was a rollover crash that occurred in Mexican Hat, Utah, where the bus overturned as it departed the roadway and rolled one full turn, striking several rocks in a drainage ditch bed at the bottom of the embankment, and came to rest on its wheels. The roof of the vehicle separated from the body, and 51 of the 53 occupants were ejected. Nine passengers were fatally injured and 43 passengers and the driver received various injuries.

The second 2008 event was a crash in Sherman, Texas, where the bus went through the bridge railing and off the bridge. As a result of the accident, 17 passengers died. Among the NTSB findings, the report concluded that the overhead luggage rack had detached from its mounting and fell diagonally across the aisle onto the passengers and impeded passenger egress and rescue efforts.

The third 2008 event was a rollover crash near Williams, California, where the bus flipped and rolled into a ditch, killing 9 people and injuring more than 30

others. According to a media report,<sup>33</sup> 30 to 38 people suffered critical injuries, while the rest of the passengers received moderate to minor injuries. Approximately a dozen passengers were ejected from the vehicle.

Separately, in 2009, a large number of fatalities were a result of a January 30, 2009 crash in which a 29-passenger tour bus overturned on a highway near the Hoover Dam, killing 7 occupants and injuring 10 others. According to the NTSB report,<sup>34</sup> the 29-passenger mid-size bus veered left out of its lane. After the driver overcorrected, the bus rolled 1.25 times before stopping. During the rollover, 15 of the 17 occupants were fully or partially ejected.

#### **b. Rollover and Ejection Statistics**

Using the aforementioned FARS bus type categories, the agency examined the FARS data to understand the proportion of occupant fatalities that resulted from rollover crashes and occupant ejections. The FARS data show that rollovers account for more than half of the occupant fatalities in these bus types. Figure 2, below, shows the 209 fatalities categorized by rollover/first impact point for the 10-year period 2000-2009. If a vehicle was involved in a rollover, it is categorized as a rollover crash since it is generally the most harmful event in a crash and results in most of these fatalities. Vehicles not involved in a rollover are categorized by first impact point (front, side, and rear).

---

<sup>33</sup> <http://www.kcra.com/news/17630435/detail.html>

<sup>34</sup> NTSB/HAR-10/01 PB2010-916201; Bus Loss of Control and Rollover Dolan Springs, Arizona; January 30, 2009.

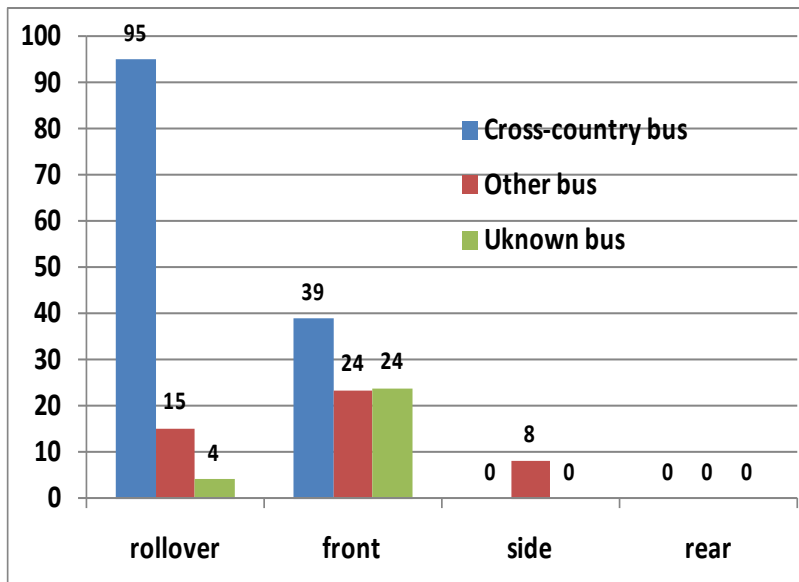

**Figure 2. Number of occupant fatalities involving cross-country, other, and unknown buses with a GVWR > 11,793 kg (26,000 lb) except for transit and school buses, by rollover/first impact point and bus body type.**

Among the 209 occupant fatalities, rollovers accounted for 114 fatalities (55 percent). Also, 71 percent of crash fatalities in cross-country buses were in rollover crashes, while 25 percent of the fatalities in other and unknown buses were in rollover crashes. There were no fatalities in rear and side impacts in cross-country and unknown bus body type categories.

The agency further examined these data and found that the vast majority of fatalities in rollover crashes involve occupant ejections. Figure 3 shows the distribution of fatalities in) rollover crashes involving these bus types (cross-country, other, and unknown buses with a GVWR greater than 11,793 kg (26,000 lb)) by occupant type and ejection status. For the ten year period from 2000 to 2009, there were 32 fatal rollover crashes, resulting in 114 fatalities. In these rollover crashes, two thirds (78 out of 114) of the fatalities were occupants who were ejected. Three drivers (3 percent) involved in rollover crashes were ejected.

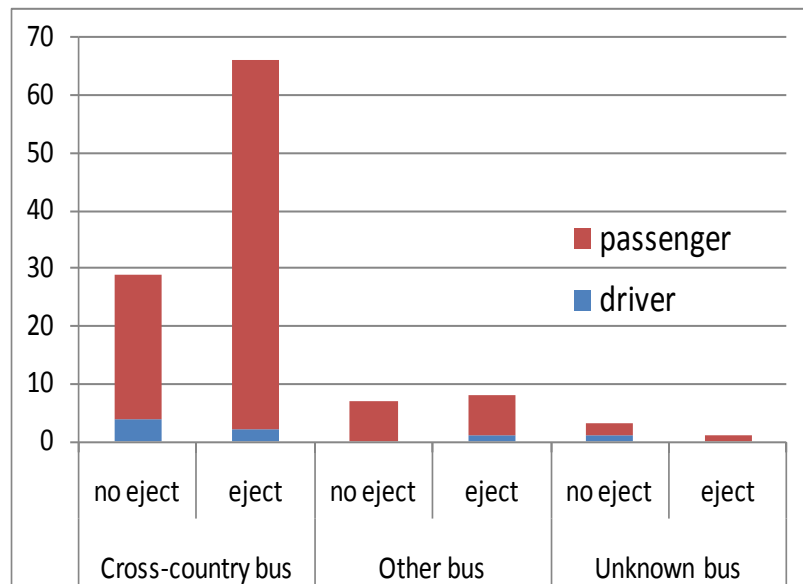

**Figure 3. Number of rollover fatalities in cross-country, other, and unknown buses with a GVWR > 11,793 kg (26,000 lb) except for transit and school buses, among drivers and passengers by ejection status and bus body type.**

While a large percentage of fatalities in rollover crashes are due to the occupants being ejected, some fatalities can be attributed to the collapse of structure during the rollover event. On May 31, 2011, a 2000 Setra bus carrying 58 passengers from Greensboro, North Carolina to New York City on Interstate 95 departed the roadway near Doswell, Virginia, rolled 180 degrees, and landed on its roof. NTSB, which is investigating this accident, noted that there was considerable deformation of the roof into the occupant survival space as evidenced by the seat back deformation resulting from contact with the roof structure. The passenger seats were not equipped with seat belts. Four passengers were killed as a result of encroachment of the occupant survival space by the roof and fourteen passengers sustained serious injuries. The driver, restrained by a lap belt, was not injured.

The agency is proposing the requirements in today's NPRM to improve rollover safety in large buses. The aforementioned data show that crashes involving rollovers and

ejections present the greatest risk of death to the occupants of these buses. The majority of fatalities occur in rollovers, and two-thirds of rollover fatalities are associated with occupant ejection, particularly passenger ejection. There is also real world evidence that bus occupants retained in the bus during rollover events may sustain serious to fatal injuries due to structural collapse. The proposed requirements work in conjunction with the seat belt requirements by enhancing the protection of restrained and retained occupants in rollovers and reducing the risk of ejection of occupants who are not restrained.

#### **IV. NHTSA's Large Bus Rollover Structural Integrity Research**

In support of this rulemaking initiative, the agency evaluated two existing roof crush/rollover standards: FMVSS No. 220, "School bus rollover protection," and ECE R.66, "Uniform Technical Prescriptions Concerning the Approval of Large Passenger Vehicles with Regard to the Strength of their Superstructure."<sup>35</sup> We sought to evaluate the extent to which the standards would address the aforementioned safety concerns, particularly as to providing a minimum level of protection for vehicle occupants who are retained in the vehicle after a rollover.

The agency purchased three different bus models for this test program. Two older models were selected because they were representative of the range of roof characteristics (such as design, material, pillars, shape, etc.) of large bus roofs in the U.S. fleet. The vehicles selected were two 12.2 meters (m) (40 feet) long MY 1992 MCI model MC-12,

---

<sup>35</sup> ECE R.66 defines "superstructure" as "the load-bearing components of the bodywork as defined by the manufacturer, containing those coherent parts and elements which contribute to the strength and energy absorbing capability of the bodywork, and preserve the residual space in the rollover test." "Bodywork" means "the complete structure of the vehicle in running order, including all the structural elements which form the passenger compartment, driver's compartment, baggage compartment and spaces for the mechanical units and components." (Footnote added.)

and two 12.2 m (40 feet) long MY 1991 Prevost model (Prevost) LeMirage buses. The MCI and Prevost models were selected because they were similar in size and weight but exhibited visible differences in construction. The most discernible difference between these two models was that of the two, the Prevost LeMirage had smaller side windows and more roof support pillars.

Many buses, newer than those MCI and Prevost models, are 13.7 m (45 feet) instead of 12.2 m (40 feet) in length. Thus, the agency believed that manufacturers could have significantly redesigned their bus models when introducing the longer designs. Thus, the agency also procured a MY 2000 MCI bus, Model 102-EL3, that was 13.7 m (45 foot) in length.

All five of the buses purchased were tested to requirements in either FMVSS No. 220 or ECE R.66. For further information on the four older buses tested, a detailed discussion of the tests and results are available in the docket entry NHTSA-2007-28793-0019. For further information on the newer vehicle tested, see the test report, “ECE Regulation 66 Based Research Test of Motorcoach Roof Strength, 2000 MCI 102-EL3 Series Motorcoach, NHTSA No.: MY0800,” October 1, 2009, Report No.: ECE 66-MGA-2009-001, which can be found on NHTSA’s website.<sup>36</sup>

**a. Findings of the FMVSS No. 220-Based Tests**

In evaluating FMVSS No. 220, the agency used one of the MY 1992 MCI buses and one of the MY 1991 Prevost buses.

---

<sup>36</sup> [http://www-nrd.nhtsa.dot.gov/database/asp/searchmedia2.aspx?database=v&tstno=6797&mediatype=r&r\\_tstno=6797](http://www-nrd.nhtsa.dot.gov/database/asp/searchmedia2.aspx?database=v&tstno=6797&mediatype=r&r_tstno=6797), Report 8. Step-by-step instructions on accessing the research report can be found in a memorandum in Docket No. NHTSA-2007-28793-0025.

The FMVSS No. 220 test applies a uniformly distributed compressive load (equivalent to 1.5 times the unloaded vehicle weight (UVW) of the bus), on the roof of the bus along the vehicle's longitudinal centerline using a 915 mm (3 feet) wide platen that is 305 mm (1 foot) shorter than the bus length. The requirements are that the bus roof must not compress more than 130 mm (5.118 inches) and that the emergency exits remain operable.

Since there were some uncertainties regarding the strength of the bus roofs and whether they could withstand a force of 1.5 times the unloaded vehicle weight (UVW), we slightly changed how the FMVSS No. 220 test was conducted. In particular, when the applied force reached the magnitude of 0.5 times UVW and 1.0 times UVW, the force was held constant at that level for a period of time in order to examine the operability of the emergency exits. In addition, survival space templates<sup>37</sup> (similar to those used in the ECE R.66 test) were installed for comparison with the results with the ECE R.66 tests.

Neither the MY 1992 MCI nor the MY 1991 Prevost bus was able to meet the 1.5 times the UVW required for school buses. For the MCI bus, a peak load of 0.91 times UVW was achieved when the force application device reached its maximum displacement range. Approximately 13 seconds after the peak force was recorded, contact was made between the front survival space template and the left and right overhead luggage racks. The emergency exit windows were operable after the load reached 0.5 times UVW and after the test with the load removed.

---

<sup>37</sup> The templates are used to delineate the occupant survival space. The templates are 1,250 mm (50.2 inches) tall and are tapered from the sidewall a distance of 150 mm (5.9 inches) at the bottom and 400 mm (15.8 inches) at the top. Several templates are placed in the bus passenger compartment. Encroachment of any bus structure into the survival space, as delineated by the templates, would be prohibited by ECE R.66.

For the MY 1991 Prevost bus, a peak load of 1.17 times UVW was achieved during the test. This peak load was reached when the force application device reached its maximum displacement range. Approximately 12 seconds after the peak load was reached, contact was made between the front survival space template and the left and right overhead luggage racks. The emergency exit windows were operable after the load reached 0.5 times UVW and after the test with the load removed. However, no measurements were made at 1.0 times UVW for safety reasons.

We made the following observations from the tests. Even though the buses we tested were heavier, larger, and structurally different than school buses,<sup>38</sup> the testing demonstrated that FMVSS No. 220's test protocol could be adapted to test these vehicles with only minor changes to the test device and procedure for mounting and stabilizing the bus on the test device. The testing further showed that the front sections of these two bus models are weaker than the back. We believe this is because the windshield and service door are located in the front of the bus and offered little resistance to the compressive load. The front of the MY 1992 MCI bus yielded to the compressive load at 0.91 times UVW, while the front of the MY 1991 Prevost bus yielded at 1.17 times UVW.

#### **b. Findings of the ECE R.66-Based Tests**

##### Testing of Older Bus Models

The agency also used one of the MY 1992 MCI buses and one of the MY 1991 Prevost buses to evaluate the ECE R.66 test procedure.

---

<sup>38</sup> Generally, large bus designs are integral constructions whereas school buses are the traditional body-on-chassis designs. The loads specified in FMVSS No. 220 are applied to the frame structure of the school bus chassis which is easy to identify. In contrast, identifying load bearing points on a large bus can be challenging and requires some understanding of its construction. The location of load bearing points can vary for different designs. In the two large buses tested, the loads were applied at load bearing points near the wheel supports.



In the ECE R.66 full vehicle test, the vehicle is placed on a tilting platform that is 800 mm above a smooth and level concrete surface. One side of the tilting platform along the length of the vehicle is raised at a steady rate of not more than 5 degrees/second until the vehicle becomes unstable, rolls off the platform, and impacts the concrete surface below. The vehicle typically strikes the hard surface near the intersection between the sidewall and the roof. The encroachment of the survival space during and after the rollover structural integrity test may be assessed using high speed photography, video, deformable templates, electric contact sensors, or any other suitable means.

In our research, high speed video cameras and transfer media were applied to each survival space template in order to determine if any portion of the vehicle interior had entered the occupant survival space during the rollover crash. In addition, two Hybrid III (HIII) 50<sup>th</sup> percentile adult male Anthropomorphic Test Devices (ATDs) (test dummies) were installed in the vehicle to measure injury potential and seat anchorage performance.

We observed the following in our tests of the older buses:

--The testing demonstrated that it is practicable to apply the ECE R.66 complete vehicle test to the large buses being considered in today's NPRM. However, neither of the two buses tested was able to meet the requirement to maintain the integrity of the survival space during and after the test. Contact between the front survival space template and left side window was made on both bus models. As in the FMVSS No. 220-based tests, the testing indicated that the front sections of these two models were weaker than the rear. We believe this is because the windshield and service door are in the front of the bus and offered little resistance upon impact with the ground.

--On both buses, the windows on the impact side remained intact. The high speed video footage from both tests indicated that the side windows located on the far-side of

the impact underwent a substantial amount of flexion during the impact with the ground but remained intact. The windshield broke from its mounting and fell to the ground.

-- For both buses, the roof emergency exits opened when the bus impacted the ground. The video footage also indicated that the side emergency exit windows on the Prevost bus unlatched and opened but closed when the bus came to its final resting position.

--On the MY 1992 MCI bus, all of the left side overhead luggage rack inboard hangers (hangers connect the overhead luggage rack to the ceiling of the vehicle, and are spaced along the length of the rack to hold it up) rearward of the front two hangers, broke during the impact, leaving exposed sharp metal edges.

--For the MY 1991 Prevost bus, all the seats on the right side (opposite the impact side) of the bus detached from their wall mounts and the seat with the restrained dummy broke completely from its anchorages.

--The Injury Assessment Reference Values (IARVs) were relatively low for the ATDs restrained by the seat belts (even for the seat in the Prevost bus that broke away from its side and floor anchorages). However, for the ATDs that were unrestrained, the type and severity of the injury indicated by the dummy IARVs depended on how they fell from their initial seated position during the rollover sequence. In the case of the MCI bus, the unrestrained ATD received only one IARV (neck injury criterion  $N_{ij} = 1.10$ ) that was over the performance limit used in FMVSS No. 208, "Occupant crash protection." However, in the case of the MY 1991 Prevost bus, the unrestrained ATD fell across the bus head-first onto the side window which was in contact with the ground, resulting in multiple IARVs exceeding the performance limits specified in FMVSS No. 208. The dummy resulted in multiple IARVs that were well above the acceptable limits.

### Testing of a Newer Bus Model

NHTSA also conducted the ECE R.66 test on a MY 2000 MCI bus Model 102-EL3 that was 13.7 m (45 foot) in length. This test was conducted to determine whether the ECE R.66 test protocol could be applied to the larger and heavier buses sold in the United States and to examine different ballasting methods. Survival space templates were installed and the vehicle was placed on a tilting platform that was 800 mm above a smooth and level concrete surface. One side of the tilting platform was raised at a steady rate of not more than 5 degrees/second until the vehicle became unstable, rolled off the platform, and impacted the concrete surface below. See, "ECE Regulation 66 Based Research Test of Motorcoach Roof Strength, 2000 MCI 102-EL3 Series Motorcoach, NHTSA No.: MY0800," October 1, 2009, *supra*.

Occupant ballasts were used in the test, as specified in ECE R.66. ECE R.66 specifies the option of two different methods of securing occupant ballast to the passenger seats. NHTSA tested both types of ballasts to determine the feasibility of each and the differences (if any) that exist between the two. The agency believed that ballasting was important because it increases the weight and raises the center of gravity of the vehicle, making the rollover structural integrity test more stringent and representative of a rollover crash of a fully loaded bus. In addition, the seat anchorages experience the forces in a rollover when the seat is occupied by an average sized restrained occupant.

NHTSA evaluated the two ballasting methods to assess the feasibility and merits of the ballast methods. Four anthropomorphic ballasts, commercially available "water

dummies,”<sup>39</sup> were installed in one full row of seats (four seating positions) and were secured with ratchet straps that were configured to simulate Type 2 seat belts. The dimensions of the anthropomorphic ballasts used in this test are shown in Figures 5(a) and 5(b), below. The water dummies were each filled with 68 kg (150 lb) of sand. Steel ballasts, 68 kg (150 lb) per seating position, were installed in a second full row of seats (four seats). In this row, steel plates were placed on top of each seat cushion and were secured with bolts that passed through the cushion and attached to a bar which clamped onto the seat frame. (In the ECE R.66 test, each designated seating position with occupant restraints would be ballasted.)

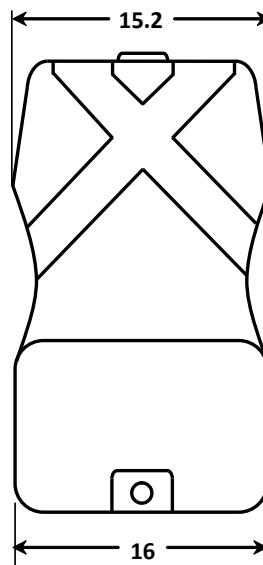

**Figure 4(a). Front view of water dummy. All dimensions are in centimeters.**

<sup>39</sup> These water dummies are plastic containers constructed to simulate the torso shape of a passenger and can be secured in place using belts. Such water dummies have the capacity to be loaded to a weight of 176 pounds (80 kg). However, since the GVWR of a vehicle is typically estimated using an occupant weight of 150 pounds per seating position and since ECE R.66 specifies ballasts of 150 pounds, the agency only loaded the water dummies to 150 pounds. The water dummies were filled with sand instead of water because filling the ballast partially with water would cause the water’s mass to slosh during the rollover test, possibly introducing some variability.

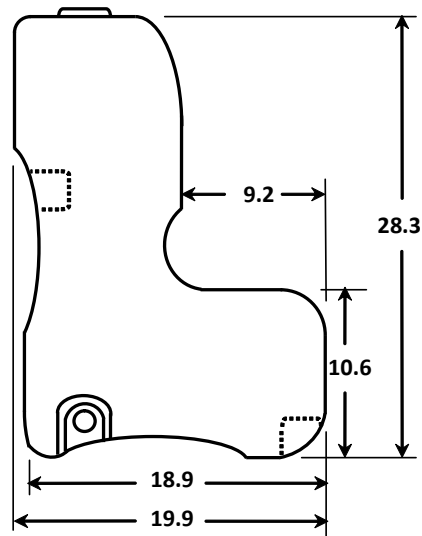

**Figure 4(b). Side view of water dummy. All dimensions are in centimeters.**

We also seated two 50<sup>th</sup> percentile adult male ATDs on the opposite side of the impact. This arrangement was similar to the earlier tests with the older buses.

We observed the following in our test of this MY 2000 bus:

-- Based on an analysis of image data from the high-speed camera located outside the vehicle, it appears that a side pillar in the front of the vehicle along the impact side may have intruded into the survival space. However, this was not assessed using the survival space templates since they were not located at the position of the side pillar during the test, and there was no contact between the survival space templates and the bus structure.

-- During impact, the glazing on five of the seven windows on the right side of the bus (opposite the impacted side) dislodged from their window mounting and fell into the occupant compartment during the test. The glazing in one of the windows was retained by an overhead TV monitor and prevented the window pane from separating from its mounting gasket and falling into the bus. The glazing in the last window near the rear shattered, but was retained and did not fall into the passenger compartment, apparently

because the window was shorter in length than the other windows. After the bus impacted the ground, both sides of the windshield lost retention and fell from its supporting structure.

--All side emergency exit windows remained latched during the test. However, both roof emergency exits opened when the roof of the bus impacted the ground.

--The ATD restrained by the seat belt measured forces that were below the FMVSS No. 208 IARVs. However, the unrestrained ATD had multiple IARVs that were well above the acceptable limits.

--In terms of the feasibility of the test procedure, the testing showed that it was possible to ballast the seats with either the anthropomorphic ballast or steel weights. All of the seats with both types of ballast remained attached to their original anchorages.

## **V. Proposed Requirements**

### **a. Overview**

This NPRM proposes performance requirements that the large buses covered by this rulemaking must meet when tested by NHTSA using a test substantially modeled after the complete vehicle test of ECE R.66.<sup>40</sup> In the rollover structural integrity test, the vehicle would be loaded with up to 68 kg (150 lb) of weight in ballasts at each designated seating position in order to simulate the load of occupants on both vehicle structure and the seat anchorages. The following are the proposed performance requirements when the vehicle is subjected to the rollover structural integrity test:

(1) intrusion into the survival space, demarcated in the vehicle interior, by any part of the bus outside the survival space is prohibited;

---

<sup>40</sup> ECE R.66 includes several “equivalent approval tests,” including body section testing and computer simulations. In a later section, we discuss why we believe these alternative compliance methods would not be suitable for incorporation into today’s proposed Federal motor vehicle safety standard.

(2) each anchorage of the seats and interior overhead luggage racks and compartments shall not completely separate from its mounting structure;

(3) emergency exits must remain shut during the test and roof and rear emergency exits must be operable in the manner required under FMVSS No. 217 after the test; and

(4) each side window glazing opposite the impacted side of the vehicle must remain attached to its mounting such that there is no opening that will allow the passage of a 102 mm diameter sphere.

**b. Applicability**

In this rulemaking, the agency's goal is to apply the proposed requirements in today's NPRM to generally the same group of vehicles that are covered by the seat belt final rule. The agency tentatively believes that it would make sense to apply today's proposed requirements generally to the same group of vehicles that are covered by the seat belt final rule. Both rulemakings are intended to address different facets of occupant harm occurring from the rollover event. Both standards would apply to the vehicles associated with unreasonable risk of harm in rollovers. The agency tentatively concludes that this rollover-specific NPRM should apply to high-occupancy vehicles associated with unreasonable risk of fatal rollover involvement and that these vehicles are generally buses with a GVWR greater than 11,793 kg (26,000 lb).

In order to achieve this, the agency proposes to apply the requirements to two types of buses: (a) all new over-the-road buses (regardless of GVWR) and (b) all new buses other than over-the-road buses, with a GVWR greater than 11,793 kg (26,000 lb).<sup>41</sup> While the vast majority of over-the-road buses have a GVWR greater than 11,793 kg

---

<sup>41</sup> Transit buses, school buses, and perimeter-seating buses would be excluded from the standard under this latter category.

(26,000 lb), the agency proposes to take this two-prong approach towards determining applicability of the proposed standard in order to cover all of the buses covered by MAP-21 and all of the buses with similar safety risks as the buses covered under MAP-21.

#### MAP-21 and Over-the-road Buses

As described above, the large bus rulemaking provisions in MAP-21 apply to “motorcoaches” which are defined as “over-the-road buses.” An over-the-road bus is, in turn, defined as “a bus characterized by an elevated passenger deck located over a baggage compartment.” In order to cover this group of vehicles, we propose in this NPRM to use the language from MAP-21 and apply the proposed requirements to “over-the-road buses.” Further, we propose to adopt the definition incorporated in MAP-21 and define over-the-road buses as buses that are characterized by an elevated passenger deck located over a baggage compartment.<sup>42</sup>

The agency believes that the vast majority of “over-the-road buses” are buses with a GVWR greater than 11,793 kg (26,000 lb). However, rather than simply applying the proposed requirements to buses (of any type) with a GVWR greater than 11,793 kg (26,000 lb) the agency tentatively believes that it is necessary to propose a separate definition for “over-the-road buses” and apply the proposed requirements to all of those buses. While most over-the-road buses have a GVWR greater than 11,793 kg (26,000 lb), the agency is not aware of any reason why buses characterized by an elevated passenger deck located over a baggage compartment (over-the-road buses) must necessarily have a GVWR greater than 11,793 kg (26,000 lb). As it is possible to design a bus with an elevated passenger deck located over a baggage compartment with a

---

<sup>42</sup> As described further, below, over-the-road buses include buses operated by public transit agencies so long as they meet the over-the-road bus definition (buses characterized by an elevated passenger deck located over a baggage compartment).



GVWR less than 11,793 kg (26,000 lb), the agency tentatively believes that it is necessary to apply the proposed requirements to all over-the-road buses (regardless of GVWR) in order to cover all the buses contemplated by Congress in MAP-21. In addition, the agency believes that over-the-road buses (as characterized in MAP-21) are likely to be used for high-speed intercity travel (where rollover crashes are more likely to occur) regardless of the vehicle's GVWR.

Buses Other than Over-the-road Buses with a GVWR Greater Than 11,793 kg (26,000 lb)

However, in addition to the buses contemplated by Congress in MAP-21, the agency proposed to also cover other types of buses<sup>43</sup> so long as those buses have a GVWR greater than 11,793 kg (26,000 lb). As discussed in the "Safety Need" section of this preamble, FARS data for 2000-2009 show that rollovers constitute a large safety problem for buses with a GVWR greater than 11,793 kg (26,000 lb). FARS data show that rollovers (32 crashes, 114 fatalities) accounted for 34 percent of the fatal crashes yet more than 50 percent of the occupant fatalities. In these rollover crashes, two-thirds of the fatalities were passengers who were ejected. The data indicate that, for these vehicles, rollover crashes and occupant ejections are more likely to cause fatalities than other types of crashes.

As mentioned earlier, NHTSA is proposing to adopt the requirements in today's NPRM under its authority in both the Motor Vehicle Safety Act and the relevant provision of MAP-21. While the relevant provisions of MAP-21 instruct this agency to examine "over-the-road buses" (buses characterized by an elevated passenger deck located over a baggage compartment) in any roof strength and anti-ejection

---

<sup>43</sup> Except transit buses, school buses, and perimeter seating buses

rulemakings,<sup>44</sup> no provision in MAP-21 limits the agency's ability to examine other types of buses pursuant to its existing authority under the Motor Vehicle Safety Act.

Given the available data, the agency believes that limiting the scope of this rulemaking to "traditional motorcoaches" (over-the-road buses) would be only a partial and incomplete response to the safety problem. As discussed above, the FARS data for 2000-2009 show that buses other than over-the-road buses were often involved in high speed crashes involving multiple passenger fatalities. The FARS data show that 64 percent of the fatalities were in cross-country/intercity buses (considered traditional over-the-road type buses) and 36 percent were in the "other bus" and "unknown bus" categories. While these "other" and "unknown" buses have a non-traditional (e.g., body-on-chassis) design and appearance, these buses are of a similar size, seating configuration, and function as an over-the-road bus type. As a result, these buses are associated with similar safety risks as over-the-road buses. Thus, the agency is currently unaware of a rationale that would support excluding these "other" and "unknown" buses from today's proposed requirements.

As the data indicate, the safety risks associated with rollover accidents in large buses are not limited to only traditional motorcoaches (over-the-road buses). Thus, the agency proposes to apply the proposed requirements in today's NPRM to buses other than those called "motorcoaches" in MAP-21. Beyond the "over-the-road" buses identified by MAP-21, NHTSA proposes to apply the proposed requirements to generally the same universe of vehicles to which the seat belt final rule applies. The agency believes that the proposed rule should apply to all buses with similar rollover crash risks.

---

<sup>44</sup> See Moving Ahead for Progress in the 21<sup>st</sup> Century Act, Pub. L. No. 112-141, § 32703(b).

Buses Other than Over-the-road Buses with a GVWR between 4,536 and 11,793 kg  
(10,000 and 26,000 lb)

On the other hand, buses with a GVWR between 4,536 and 11,793 kg (10,000 and 26,000 lb) do not have the same rollover crash risks as the aforementioned bus categories. Thus, while comment is requested on this subject, this NPRM tentatively has not included these buses in today's proposal. According to the FARS 2000-2009 data files, there were 42 occupant fatalities in crashes involving cross-country buses, other buses, and unknown buses with a GVWR between 4,536 and 11,793 kg (10,000 and 26,000 lb) in this 10-year period (see Table 5, supra). Among these 42 occupant fatalities in buses with a GVWR between 4,536 and 11,793 kg (10,000 and 26,000 lb), 24 fatalities were a result of 13 rollover crashes. Thus, over the ten year period between 2000 and 2009, buses with a GVWR between 4,536 and 11,793 kg (10,000 and 26,000 lb) were associated with an average of 1.3 rollover crashes per year and 2.4 fatalities per year. In contrast, there was an average of 3.2 rollover crashes among buses in these same categories with a GVWR greater than 11,793 kg (26,000 lb) per year. These crashes resulted in an average of 11.4 fatalities per year. Among all fatalities occurring in rollover crashes in cross-country, other, and unknown buses with a GVWR greater than 4,536 kg (10,000 lb), 83 percent are in buses with a GVWR greater than 11,793 kg (26,000 lb).

Further, the agency notes that buses with a GVWR between 4,536 and 11,793 kg (10,000 and 26,000 lb) are frequently used for demand-response transit<sup>45</sup> services.<sup>46</sup>

---

<sup>45</sup> Public transportation characterized by flexible routing and scheduling of small/medium vehicles operating in shared ride mode between pickup and drop-off locations according to passenger needs. It includes transporting persons with special mobility needs.

These demand-response transit service vehicles are used in urban areas and rarely operate at highway speeds, which are the speeds at which the majority of bus rollover fatalities occur. Compared to the estimated number of large buses sold annually (approximately 2,200 buses), there are approximately 14,600 buses with a GVWR between 4,536 and 11,793 kg (10,000 and 26,000 lb) produced annually.<sup>47</sup> Given that more of the lower weight buses are manufactured than large buses annually, applying the proposed rule to buses with a GVWR between 4,536 and 11,793 kg (10,000 and 26,000 lb) may increase the potential costs of the rule more than the potential benefits.

However, NHTSA requests comment on the issue and invites useful data, particularly related to the cost of applying the proposed rule to buses with a GVWR between 4,536 and 11,793 kg (10,000 and 26,000 lb). Are there data as to whether the cost of applying the proposed requirements to buses with a GVWR between 4,536 and 11,793 kg (10,000 and 26,000 lb) will be significantly different when compared to buses with a GVWR greater than 11,793 kg (26,000 lb)? We request data that show whether the effectiveness of the countermeasures would be different between these two bus sizes. Are there data which show how the impact on small businesses would change if the requirements of today's proposal were extended to buses with GVWR between 4,536 and 11,793 kg (10,000 and 26,000 lb)?

Although the aforementioned data show that buses with a GVWR between 4,536 and 11,793 kg (10,000 and 26,000 lb) have historically been associated with less fatalities than buses with a GVWR above 11,793 kg (26,000 lb), the agency notes these buses

---

<sup>46</sup> Evaluation of the Market for Small-to-Medium Sized Cutaway Buses, Federal Transit Administration Project #: MI-26-7208.07.1, December 2007, available at <http://www.fta.dot.gov/documents/AnEvaluationofMarketforSmalltoMediumSizedCutawayBuses.pdf>.

<sup>47</sup> See *Id.*

represent a significant number of bus sales, have a lower price (\$50,000 - \$65,000), and higher fuel economy.<sup>48</sup> As smaller buses can also be utilized to service similar routes as larger buses, it may be possible, in the future, that more crashes could occur in these types of buses if these buses experience higher sales volume and begin to service routes that result in a higher number of vehicles miles traveled. NHTSA recognizes that this proposal does not cover all the vehicles recommended by the NTSB in recommendations H-10-3 and H-10-4. As mentioned above, the NTSB recommended that NHTSA should include all vehicles with a GVWR of 4,536 kg (10,000 lb) or greater in our rulemaking. Thus, the agency is requesting comment on the above concerns.

#### Transit, School, Perimeter Seating, Prison, and Double-Decker Buses

While (in general) the agency proposes to apply the requirements in this NPRM to over-the-road buses (regardless of GVWR) and other buses with a GVWR greater than 11,793 kg (26,000 lb), the agency has considered various (more specialized) types of buses and whether or not these specific types of buses should be covered by the proposed requirements. Comments are requested on each of the following bus types and whether or not the agency should apply the proposed requirements in this NPRM to these bus types.

##### *Transit Buses*

In today's proposal we have not included transit buses as a bus category that would be subjected to today's proposed requirements. The data show that the crash risk for transit buses (i.e., buses with a stop-request system that is sold for public transportation) is much lower than for the other bus types covered by today's proposal. In order to exclude transit buses, we propose to utilize the same definition for transit

---

<sup>48</sup> *See Id.*

buses as in the seat belt final rule.<sup>49</sup> Our reasoning, like in the seat belt final rule, is that there is a significantly lower crash risk for passengers of transit buses. We believe this difference in crash risk is due in part to the stop-and-go manner of transit bus operation. The FARS data from 2000-2009 show that, for all bus body types with a GVWR greater than 11,793 kg (26,000 lb), transit buses have the fewest fatalities at 8.2 percent or 23 out of a total of 281. These same data show that there were 20 fatal crashes involving occupants of urban transit buses, resulting in fatalities of 11 drivers and 12 were passengers. Thus, fatal transit bus crashes involve about one fatality, on average. In summary, there are many fewer total fatalities and fatalities per crash for transit buses, and thus a significantly lower risk than in the other buses covered by today's proposed rule.

Like in the seat belt final rule, today's proposal explicitly states that over-the-road buses cannot qualify as transit buses (and be exempt from proposed requirements). While the agency acknowledges that state and local public transit agencies may purchase an over-the-road bus and equip such buses with a stop-request system, the agency believes that over-the-road buses used by transit agencies will likely be used in a similar manner as over-the-road buses purchased by private companies (i.e., for intercity transport carrying large numbers of passengers, over long distances, and at highway speeds). It is not uncommon to see commuter express buses traveling on the highway alongside privately-operated tour and charter buses of nearly identical construction. Thus, given the overall similarity of the buses in construction and use, we cannot distinguish, from a public safety standpoint, good reasons for distinguishing privately-

---

<sup>49</sup> Transit bus means a bus that is equipped with a stop-request system sold for public transportation provided by, or on behalf of, a State or local government and that is not an over-the-road bus.

operated versions of the over-the-road buses from those operated by state and local public transit agencies. Comments are requested on this topic.

### *School Buses*

As described in greater detail below, FMVSS No. 220 establishes roof strength requirements for school buses. While there are several reasons why the agency is proposing to use an ECE R.66-based test in today's NPRM, the agency is not proposing to alter the requirements for school buses. As further described below, there are various differences in the operating conditions the large buses covered under today's proposal and school buses covered under FMVSS No. 220 that make an ECE R.66-based test more suitable for the buses covered in today's proposal. As the safety record for school buses demonstrate that FMVSS No. 220 continues to be appropriate for those buses, the agency is not proposing to include school buses in today's proposal or to alter the requirements for school buses under FMVSS No. 220.

### *Buses with Perimeter Seating*

In the seat belt final rule, the agency did not apply the seat belt requirements to buses with perimeter seating (unless the bus with perimeter seating qualifies as an over-the-road bus). We propose to do the same for the requirements in today's NPRM. While buses that qualify as over-the-road buses (under MAP-21) are covered under today's proposal regardless of seating configuration,<sup>50</sup> we tentatively believe that it is appropriate to exclude perimeter buses that are not over-the-road buses because these buses with perimeter seating are used to carry people for a relatively short period, typically are meant to transport standees, and are spacious to accommodate baggage and other carry-

---

<sup>50</sup> In order to cover all the buses that were covered under MAP-21, this proposal specifically defines "perimeter seating buses" as buses that are *not* over-the-road buses. Therefore, over-the-road buses are covered under today's proposal without regard to their seating configuration.

on items and to maximize the speed of passenger boarding and alighting. Under these conditions, buses with perimeter seating are not expected to transport passengers for a long distance at relatively high speeds where rollover crashes are more common.

However, the agency requests comment on whether it is likely that buses with a GVWR greater than 11,793 kg (26,000 lb) would be configured with perimeter seating and whether such buses would be used in conditions where rollover crashes are more likely to occur. We further request comment on whether such buses should be included as a bus type subject to this proposal.

#### *Prison Buses*

While prison buses were excluded from meeting the requirements of the seat belt final rule, we have tentatively decided not to exclude prison buses from the proposed requirements of today's NPRM. In the seat belt final rule, the agency noted in response to comments that certain structural aspects of prison buses (e.g., fiberglass or stainless steel low-back seats or benches) are not conducive to install seat belts. Further, we noted the security concern that lap/shoulder belt equipment could pose hazards as the buckle hardware and belt webbing could be used as weapons or tools. However, these similar concerns are not present when considering the proposed requirements in today's NPRM.

Designing the roof of a prison bus to better withstand an impact during a rollover crash is unlikely to involve any equipment that needs to be installed on the passenger seats or any equipment that could be potentially used as weapons/tools. However, the agency requests comment on whether or not it is reasonable to exclude prison buses from the proposed requirements in this rulemaking. If the recommendation is to exclude prison buses, what is the rationale for doing so? Is it reasonable to exclude prison buses from all of the requirements proposed in this NPRM or would it be appropriate to apply



some—but not all—of the requirements proposed (e.g., emergency roof exit requirements but not the survival space requirements)?

#### *Double-Decker Buses*

The agency notes that the requirements of ECE R.66 do not apply to double-decker buses while NHTSA's proposal does not exclude them from rollover structural integrity requirements.

We have tentatively decided that the proposed test procedure is not appropriate for and should not be applied to the upper/open section of open-top double-decker buses because there would be no structure to intrude into any defined survival space in the upper/open level. However, we believe that lower/enclosed sections of such vehicles (or the upper/enclosed section of a double-decker bus) can still be tested under the proposed test procedure for compliance with the requirements of the proposed rule. In the lower/enclosed or upper/enclosed level, there would be vehicle structure that could intrude into the survival space in the same fashion as a traditional bus that does not have an open-top. Comments are requested on any technical reasons that would preclude the proposed test from being applied to the enclosed section of double-decker buses, and on whether additional provisions in the regulatory text are needed in order to further account for testing of double-decker buses.

#### **c. Test Procedure**

The agency proposes in today's NPRM that compliance with the proposed performance requirements will be measured by NHTSA<sup>51</sup> using a test substantially

---

<sup>51</sup> As with all the FMVSSs, this standard would not require vehicle manufacturers to use the test to certify their vehicles. They may certify their vehicles using other means. Manufacturers must ensure, however, that their vehicles will meet the FMVSS requirements when tested by NHTSA when we use the test procedure specified in the FMVSS. If the vehicle does not meet the requirements when tested by NHTSA,

patterned after the complete vehicle test of ECE R.66. Similar to the ECE R.66 complete vehicle test, the proposed test would specify that the vehicle is placed on a raised platform that is 800 mm (31.50 inches (in)) above a horizontal, dry and smooth concrete ground surface. The test would allow NHTSA to position the vehicle such that either side (right and left) of the vehicle may be tested for compliance. The tilting platform would be raised, on one side, at a rate not to exceed 5 degrees/sec along an axis no greater than a 100 mm horizontal distance from the edge of the impact surface closest to the tilting platform and 100 mm below the top of the platform surface, until the vehicle becomes unstable and commences the rollover. The tilting platform would be equipped with wheel supports to maintain the vehicle's position on the tilting platform before the vehicle becomes unstable and commences the rollover.

#### Ballasts Representing Restrained Occupants

To simulate a real-world rollover, the agency believes it would be appropriate to subject the vehicle to the forces resulting from the mass of restrained occupants. To achieve this, this NPRM proposes that a mass of 68 kg (150 lb) be secured in each designated seating position equipped with a seat belt system. The ballast would have to be restrained in such a manner that the ballast does not break away during the test. The 150-lb ballast would represent the mass of an "average" occupant at each designated seating position. (The 150 lb value is used in determining the vehicle's gross vehicle weight rating in accordance with 49 CFR Part 567, "Certification.")

---

we will ask the manufacturer for the basis for its certification. If the agency is satisfied that the manufacturer exercised due care in making the certification, the agency may decide not to pursue civil penalties against the manufacturer for the failure of the vehicle to comply. The manufacturer is still subject to the requirements of the National Traffic and Motor Vehicle Safety Act to recall the noncomplying vehicles and remedy the noncompliance free of charge.

The agency believes that ballasting is important because it increases the weight and raises the center of gravity of the vehicle to simulate the forces upon the vehicle structure in a rollover crash when the seats are occupied by restrained passengers. Also, when occupants are belted into the vehicle, their mass imparts crash forces to the seat anchorages during a crash.

While the agency believes that ballasting is important, we have tentatively concluded that the method of ballasting and type of ballast used is not important because these factors will not significantly alter the forces upon the vehicle structure or the seat anchorages during compliance testing, so long as the ballast is 150 lb. We note that ECE R.66 does specify the option of using two different occupant ballasts: anthropomorphic ballasts (commercially available “water dummies”), and fixed steel plates. The ECE regulation stipulates that if the ballast is an anthropomorphic ballast, it is secured using a seat belt restraint, and if the ballast is a rigid weight it is securely attached to the seat frame.

In its research, NHTSA tested both ballasting methods from ECE R.66 and the results did not show a significant difference between these methods in terms of the effect on test results. We tentatively believe that the test results of the complete vehicle rollover test will not be significantly altered so long as a 150-lb ballast is secured to each designated seating position equipped with the seat belt system. We recognize that the center of gravity of the ballast can vary depending on the manner in which it is secured to the seat and the type of ballast it is. However, as explained below, the agency tentatively believes that the difference in the ballasts will not significantly alter the loads applied to the vehicle structure (as a whole) or to the seat anchorages.

We analyzed the effect of the different center of gravity heights for the anthropomorphic ballasts and the fixed weight ballasts and found that the overall center of gravity of the vehicle—and, consequently, the energy absorbed in the rollover structural integrity test of the fully loaded vehicle—is only slightly higher (less than 3 percent higher)<sup>52</sup> when using anthropomorphic ballasts as opposed to when using fixed weights as ballasts positioned on the seat cushion. We believe that this difference in the stringency of the rollover structural integrity test using different ballasts is small and within the overall accepted variability in the test procedure.

Further, we analyzed the forces and moments generated at the anchorages due to the ballasts during the rollover impact sequence and found that the difference in moment at the anchorages due to the loading from the fixed weight ballast and that from the anthropomorphic ballast during impact is approximately 350 Nm.<sup>53</sup> This value is small in comparison to the moments at the seat anchorages due to the 3,000 lb loads on the

---

<sup>52</sup> The effect of ballasts (and the type of ballast) is greatest for the lowest weighing vehicle to which the rollover test applies, which is, by definition, a vehicle with a GVWR of 26,001 pounds. For determining the effect of the ballasts and type of ballasts, the following estimations were made: The unloaded weight of the 55 occupant motorcoach is 26,001 pounds, the center of gravity of the unloaded motorcoach is 1.22 m (48 in) above ground, the height of the seat cushion of seats in the bus is 1.5 m (60 in) above ground, and the height of the center of gravity of a 68 kg rigid weight and that of an anthropomorphic ballast in the vehicle seat is 1.57 m (62 in) and 1.7 m (67 in) above ground, respectively. The addition of a 68 kg ballast at each of the 55 seats increases the weight of the vehicle by 32 percent. The center of gravity height above ground of the fully loaded vehicle is higher than that of the unloaded vehicle by 7 percent when rigid weights are used and by 9.5 percent when anthropomorphic ballasts are used. Through film analysis of the motorcoach rollover tests, we estimated that the center of gravity of the unloaded motorcoach drops approximately 0.85 m during the test. We then estimated that the total energy absorbed by the fully loaded motorcoach ( $=9.81 \times \text{total mass (kg)} \times \text{drop in center of gravity during the rollover test}$ ) is 3 percent greater when anthropomorphic ballasts are used than when rigid weights are used. Since the effect of ballasts is greatest for the 26,001 lb GVWR motorcoach, the difference in the center of gravity height and the energy absorbed for different ballast types will be significantly less than 3 percent for motorcoaches with a GVWR more than 26,001 lb.

<sup>53</sup> Assuming that the ballast is fully coupled to the seat, the moment at the seat anchorages generated by the ballast is equal to the product of the mass of the ballast, its acceleration, and the height of the ballast center of gravity. In the agency's three ECE R.66 tests, the peak motorcoach floor acceleration was approximately 4 gs and since the seat is fully coupled to the floor, we estimated the ballast acceleration to be 4 gs. Thus the moment generated at the seat anchorages was calculated to be approximately 350 Nm ( $= 68 \text{ kg} \times 4 \times 9.81 \times (1.7\text{m}-1.57\text{m})$ ).

belts in an FMVSS No. 210 test (approximately 20,000 Nm). Further, the agency tentatively believes that this difference in moment is small when we consider the racking forces that would be acting upon the seat anchorages as a result of the vehicle's impact on the impact surface during the rollover test. During our testing of the 1991 Prevost LeMirage using the ECE R.66 complete vehicle test, all the seats on the opposite side of impact detached from their wall mounts due to the racking of the bus side walls, even though the seats were not ballasted. Therefore, we have tentatively concluded that the type of ballast does not have significant effect on the performance of the seat anchorages or the vehicle structure during the rollover structural integrity test.

Nonetheless, comments are requested on our tentative conclusion. Should the agency specify a type of ballast? If so, which types of ballasts should the agency choose and what specifications are necessary? What repeatable method should the agency establish for mounting the ballast to each designated seating position? If anthropomorphic dummies from ECE R.66 are recommended, the agency requests comment on the availability of the anthropomorphic (water dummy) ballasts in the U.S. What substances can be used to fill anthropomorphic ballasts such that the ballast would achieve a weight of 150 lb with a consistent center of gravity? We note that the anthropomorphic (water dummy) ballasts specified in ECE R.66 were plastic containers (constructed to simulate the torso shape of a passenger) with the capacity to be loaded to a weight of 176 lb (80 kg). Are anthropomorphic ballasts available which are designed to hold 150 pounds?

Separately, NHTSA has tentatively concluded that two aspects of the ballasting options allowed in the ECE R.66 complete vehicle test are not appropriate for application in our proposed test procedure.

First, we note that ECE R.66 specifies different weights depending on the type of ballast that is used during the test. The ECE regulation requires that, when anthropomorphic ballasts are used, the entire estimated weight of an individual occupant's mass of 68 kg (150 lb) is required. However, when fixed ballasts are used, only 50 percent of the estimated individual occupant's mass (34 kg (75 lb)) should be attached. The agency tentatively concludes that securing only 50 percent of the individual occupant's mass when using rigid weights would underestimate the load that will be placed on the vehicle and its seat anchorages during a rollover crash.

We note that an Australian study<sup>54</sup> estimated that 93 percent of a lap/shoulder belt restrained occupant mass, 75 percent of a lap belted occupant mass, and 18 percent of an unrestrained occupant mass are effectively coupled to the vehicle structure during rollover. In addition, a European Commission sponsored study<sup>55</sup> found that the percentage of occupant mass coupled to the vehicle structure during rollover is 90 percent for lap/shoulder belted occupants and 70 percent for lap belted occupants. Based on the above research findings, the agency tentatively concludes that the vehicle should be ballasted to the full weight of 68 kg (150 lb) at all seating positions regardless of ballast method. Using a lower weight ballast for the fixed ballast setups does not appear to adequately simulate the loading conditions of the average restrained occupant.

Second, ECE R.66 requires the rigid weight be fixed to the seat such that its center of gravity aligns with that of the anthropomorphic ballast (approximately 100 mm forward and 100 mm above the seating reference point). In our research, the agency

---

<sup>54</sup> Anderson, J., et al., "Influence of Passengers During Coach Rollover," Cranfield Impact Centre Ltd., ESV Proceedings, Nagoya, Japan, Paper No. 216, 2003.

<sup>55</sup> Enhanced Coach and Bus Occupant Safety (ECBOS), Project No. 1999-RD.11130, European Commission, 5<sup>th</sup> Framework, August 2003.

found it difficult to position and fix the rigid weights according to this specification in a consistent and repeatable manner.

Given that difficulty, we investigated whether affixing the rigid weights as specified by ECE R.66 is necessary. It appears that the answer is no. As mentioned above, we analyzed the effect of the different center of gravity heights for the anthropomorphic ballasts and the fixed weight ballasts and found that the difference in center of gravity would not significantly affect the overall performance of the vehicle in the rollover test. Thus, assuming that steel ballasts similar to those allowed in ECE R.66 are specified in the final rule, the agency tentatively concludes that it would be sufficient to locate the steel ballasts on top of the seat cushion, since loading fixed ballasts to match the center of gravity of anthropomorphic ballasts present significant logistical challenges, without a noteworthy difference in the stringency of the test.

#### Vehicle Conditions

To better ensure consistent and repeatable results, the proposed test procedure also includes specifications for various vehicle conditions. The proposed test specifies that the vehicle suspension is blocked to its normal riding position and that the vehicle tires are inflated to the manufacturer's recommended tire pressure. The proposed procedure also specifies that vehicle windows, doors, and emergency exits are fully closed and in the latched but unlocked positions. All fluids in the vehicle, including fuel, will be at maximum capacity. For environmental and test personnel safety, substitute fluids would be permitted provided the weight of the original fluid is maintained.

The agency recognizes that vehicle fluids have the potential to add weight to the test specimen. As such, we request comment on whether there are certain vehicle fluids whose levels should not be included in the specifications for test conditions.

#### **d. Survival Space**

To reduce unreasonable safety risks due to inadequate structural integrity during a rollover, the agency is proposing to set minimum standards for the structural integrity of the occupant compartment. We are proposing to define a volume of space in the occupant compartment (called the “survival space”) and require that there shall be no intrusion of the survival space by any part of the vehicle or by the impact surface during movement of the tilting platform or resulting from impact of the vehicle on the impact surface.

The agency is concerned that inadequate survival space may result in restrained occupants being injured by collapsing sidewalls, roof structure, or other objects. As the agency is currently conducting rulemaking to potentially require seat belts on the buses covered by this proposed rulemaking, the agency is also interested in ensuring that passengers (if belted) will be protected from further danger due to collapsing vehicle structure that intrudes into the survival space. Our research of the ECE R.66 test procedure showed that structural intrusions into the survival space occurred in the MY 1991, MY 1992, and MY 2000 buses. Our observations showed that the survival space templates came into contact with the side windows in the rollover structural integrity tests with the older buses. Further, our review of the outside high-speed video of the test on the MY 2000 bus indicates that the side pillars may have collapsed and intruded into the occupant survival space.

#### Defining the Survival Space

The proposed rule defines “survival space” in a manner similar to ECE R.66’s “residual space.” However, we propose to define the survival space by establishing the boundaries of the three-dimensional space, as opposed to the ECE R.66 method of



defining the boundaries through the use of transverse planes which intersect a seat reference point. Thus, this NPRM proposes to define the survival space as a three-dimensional volume with a front boundary beginning at the transverse vertical plane 600 mm in front of the forward-most point on the centerline of the front surface of the seat back of the forward-most designated seating position. The rear boundary of the survival space would be the inside surface of the rear wall of the occupant compartment of the vehicle. Comments are requested as to whether the term “occupant compartment” is clear.

The vertical boundaries on both the left and right sides of vehicle centerline are defined by three line segments (see Figure 6 below). Segment 1 extends vertically from the floor to an end point that is 500 mm above the floor and 150 mm inboard of the side wall. Segment 2 starts at the end point of Segment 1 and extends to a point 750 mm above and 250 mm horizontally inboard of the end point of Segment 1. These values are used in ECE R.66. Segment 3 is a horizontal line beginning at the end point of Segment 2 and extending to the vertical longitudinal center plane of the vehicle.

In proposing this requirement for a survival space, the agency intends to ensure that the vehicle has sufficient structural strength to ensure that the survival space during and after the rollover structural integrity test is maintained. We intend the dimensions of the survival space to define a volume of space that vehicles with a minimally acceptable degree of structural integrity should provide. The survival space requirement would serve as another indicator of the roof and sidewall strength of the vehicle. The requirement would be a reasonable proxy through which the agency could assess the adequacy of the structural integrity of the vehicle.

The agency tentatively believes that the increased structural integrity countermeasures should be applied to substantially the entire length of the vehicle. Thus, this NPRM proposes a survival space volume which runs the length of the area that can be occupied by the driver and by the passengers. Therefore, this proposed rule defines the front boundary of the survival space as 600 mm in front of the forward-most point on the centerline of the forward-most designated seating position. Additionally, the proposed rule defines the rear boundary as the rear inside wall of the occupant compartment.

The agency proposes to set the vertical boundary of the survival space using the three line segments outlined above and illustrated in Figure 6 below. These three line segments mirror the equivalent vertical boundaries used in the ECE R.66 test. The agency tentatively believes that the vertical boundaries of the survival space from the ECE regulation are appropriate for application in this proposed rule for several reasons. The vertical boundary appears reasonably related to the occupant space. Photographs from the MY 2000 MCI test report show the location of the vertical boundary of the survival space as just about level with the top of the head of the seated HIII 50<sup>th</sup> percentile adult male test dummies in the seat. “ECE Regulation 66 Based Research Test of Motorcoach Roof Strength, 2000 MCI 102-EL3 Series Motorcoach, NHTSA No.: MY0800,” October 1, 2009, *supra*. (We have also placed in the docket for this NPRM other photographs of the test dummies seated in front of survival space templates.) In addition, as increasing or decreasing the height of the vertical boundaries of the survival space could significantly alter the stringency of the rollover structural integrity test, the agency believes that there is a strong interest in maintaining similar requirements to ECE

R.66 so as to reduce the regulatory burden on manufacturers having to comply with different European and U.S. standards.

Further, as all the older model buses tested by the agency were unable to meet the survival space requirements<sup>56</sup> yet current vehicles in Europe are approved as meeting the requirements, the agency believes that setting the same vertical limits of the survival space increases the likelihood of the practicability of the U.S. standard. Therefore, the agency tentatively believes that this definition of the survival space is an appropriate, practical, and practicable proxy for ensuring that the roof and sidewalls will be able to withstand the racking forces of rollover crash.

Comment is requested on the need and basis for different boundaries for the survival space.

---

<sup>56</sup> We note that while the survival space templates in the MY 2000 motorcoach did not come into contact with objects outside of the survival space during the test, we observed intrusions into the survival space separate from the survival space templates.

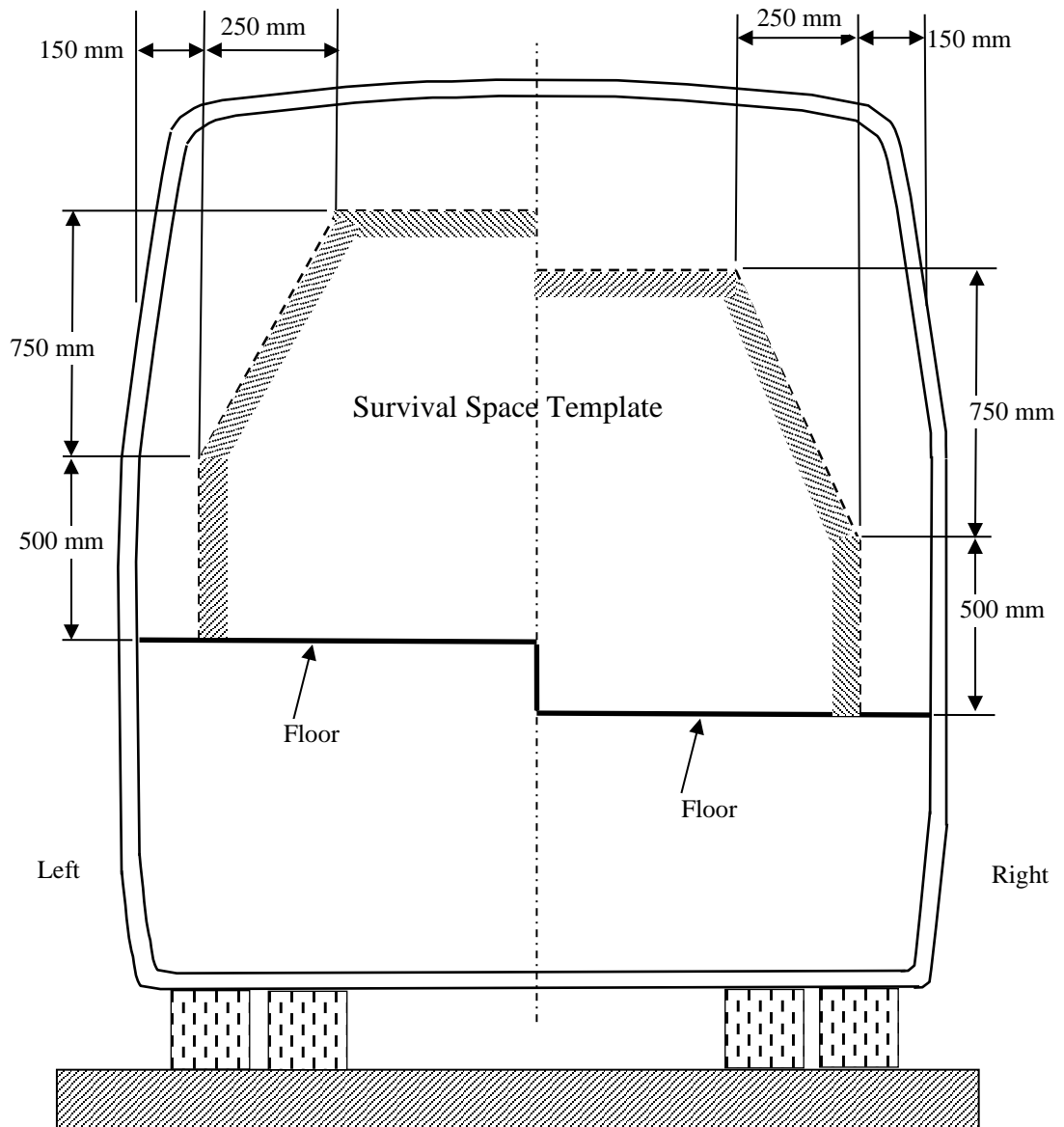

**Figure 6: Survival Space Template**

Determining Intrusions into the Survival Space

The NPRM proposes to prohibit any object that is outside the survival space from entering the survival space. Comments are requested on the use of survival space templates as tools in helping determine if there was intrusion into the survival space. Use of templates is consistent with ECE R.66. The templates are 1,250 mm (50.2 inches) tall

and are tapered from the sidewall a distance of 150 mm (5.9 inches) at the bottom and 400 mm (15.8 inches) at the top.

We anticipate using several survival space templates within the survival space to assist us in determining whether there was intrusion into the survival space. The templates would contain a transfer medium (such as chalk or another substance capable of demonstrating contact between two objects) along the upper edge of each template. Transfer marks from contact with the survival space templates would demonstrate that an object intruded into the survival space during movement of the tilting platform or resulting from impact of the vehicle on the impact surface.

We plan on securing the survival space templates to the vehicle floor such that they remain in their installed location during the test. We recognize, however, depending on seat placement and attachment, seats may have to be removed or shifted to accommodate the placement of the survival space templates or other testing equipment. Thus, we would move the seats forward or rearwards to make room for the equipment if the seat spacing is adjustable. If the seat spacing is not adjustable, we would remove seats from the vehicle and allow ballasts representing the weight of the seat and its occupants to be secured to the vehicle floor either forward or rearward of the original seat placement (within a specified tolerance<sup>57</sup>). Comments are requested on these procedures.

We emphasize that the templates are simply tools to assist in determining whether there was intrusion into the survival space. If an object intruded into the survival space without contacting the templates—such as if a television monitor fell into the survival space—that intrusion could be a noncompliance, even if contact with the templates did

---

<sup>57</sup> The proposed text in this NPRM limit the placement of these ballasts to no farther forward than the forward-most point of the motorcoach seat directly in front of the removed seat and no farther rearward than the rearmost point of the motorcoach seat directly behind the removed seat.

not occur. Other tools could also be used to help determine whether there was intrusion into the survival space, such as deformable templates, high speed video, photography, or a combination of means. NHTSA could use templates and/or other means of determining whether intrusion occurred.

**e. Overhead Luggage Rack and Seat Retention**

The agency is proposing a retention requirement for overhead luggage racks and the passenger seats. The proposed retention requirement is that each anchorage of an overhead luggage rack or seat shall not completely separate from its mounting structure during movement of the tilting platform or resulting from impact of the vehicle on the impact surface.

The NTSB identified overhead luggage racks as a safety concern in its investigation of the Sherman, Texas bus crash. The right side overhead luggage rack anchorages completely detached from the nine brackets at the connection points and fell diagonally across the aisle onto the passengers. NTSB stated that “several passengers’ heads contacted the overhead luggage rack and, although investigators were unable to determine exactly when in the accident sequence passenger injuries took place, it is possible that serious head or neck injury resulted from the interactions between the passengers and the overhead luggage rack.”

Our research confirms the possibility of this danger. In the tests conducted by the agency, the overhead luggage rack on the older MCI bus broke, exposing sharp edges that pose a risk of injury to passengers. The overhead luggage racks did not break during testing of the newer MY 2000 MCI bus. We thus acknowledge that, while this was one test, the finding indicated a possibility that manufacturers may have made some

improvements to the strength of luggage rack mounts. It also indicates the practicability of meeting the proposed requirement.

The overhead luggage rack retention requirement is an additional way of ensuring that vehicles provide a minimum level of structural integrity. The vehicle will have to limit its deformation and racking<sup>58</sup> in the rollover structural integrity test, to ensure that the overhead luggage racks meet the retention requirement. The requirement would also reduce the risk that overhead luggage racks could be dislodged and injure occupants or block or impede emergency egress.

The retention requirement would apply to luggage racks regardless of their position relative to the survival space. Suppose, in the rollover structural integrity test, an overhead luggage rack separates from its mounting structure and one of its anchorages completely separated from the anchorage's mounting structure but the overhead luggage rack does not enter the survival space. We would consider that to be a failure to meet the retention requirement.

With regard to the seats in these buses, the agency is also concerned about the strength of the anchorages that secure the seats to the vehicle. The tests conducted by NHTSA revealed the possibility that seat anchorages have the potential to break and cause injury to passengers in these buses. In our test of the MY 1991 Prevost LeMirage bus, all seat anchorages detached from their sidewall mounting anchorages and the seat with the restrained occupant completely separated from its anchorages and fell with the test dummy still attached to the seat. We acknowledge that manufacturers may have made improvements since the manufacture of that MY 1991 Prevost bus. Also, seat anchorages would likely be strengthened if these buses had to meet the requirements

---

<sup>58</sup> The term, "racking," means the tilting of the sides of the bus relative to the bus floor.

under development for passenger seat belts. However, the agency believes it is highly important for passenger safety that the vehicle structure limit deformation and racking of the sidewall, such that the passenger seats will remain attached to the vehicle in a rollover (particularly if passengers are restrained to the seat). It is important to ensure the structural integrity of the bus in a rollover will enable the seat anchor to withstand the load of the seat and that of the restrained occupant.

Compliance would be assessed by inspection of the component's mounting structure. We propose to permit the anchorage to be damaged or deformed during the course of the rollover, but we would prohibit any one anchorage from completely separating with the mounting structure. A complete separation is indicative of unacceptable structural integrity.

Comments are requested as to what other items should be covered by these retention requirements (e.g., television monitors). Please provide data supporting the safety need for your suggestion. What methods are available to the agency to objectively and practicably evaluate the retention of the item?

**f. Emergency Exits**

The agency is not only concerned with the protection of belted occupants, but also with protecting unbelted occupants. The agency recognizes there is a possibility that not all occupants traveling in the buses covered by today's proposal will be restrained at all times during travel. For instance, passengers may need to occasionally move about the occupant compartment during long, intercity journeys. Further, MAP-21 directs the agency to consider "portal improvements to prevent partial and complete ejection of



motorcoach passengers.”<sup>59</sup> Thus, the agency is considering—as a part of this rulemaking—requirements that emergency exits remain latched so as to avoid becoming an ejection portal for unrestrained occupants.

In the ECE R.66 tests conducted by the agency in support of this NPRM, the emergency roof exits of all the tested buses (new and old) opened upon impact of the bus with the impact surface. The agency is concerned that emergency roof exits may become ejection portals through which unrestrained passengers could be ejected during a rollover crash. Therefore, the agency has proposed a requirement in today’s NPRM that all emergency exits shall not open during the rollover structural integrity test. While the agency has tentatively determined that this requirement (remaining closed during and after the rollover test) would be appropriate for the emergency exits, the agency also requests comments on whether other similar openings exist in the bus that could also become ejection portals in a similar fashion to emergency exits and whether they should also be subject to the proposed requirements. For example, are there other windows or roof hatches that are designed to open in buses that are not emergency exits? Do these openings have similar safety concerns?

In addition, for emergency exits, NHTSA also seeks to increase the likelihood that roof and rear door emergency exits are operable after a rollover crash.<sup>60</sup> Inoperable emergency exits would impede emergency egress and emergency rescue efforts. Accordingly, we have proposed to require that the emergency exits on the roof and at the rear of the bus (installed to fulfill the emergency exit requirements of FMVSS No. 217) be able to operate as required under FMVSS No. 217 after the impact. The agency

---

<sup>59</sup> See Moving Ahead for Progress in the 21<sup>st</sup> Century Act, Pub. L. No. 112-141, § 32703(b)(2).

<sup>60</sup> The provisions of MAP-21 also direct the agency to consider the impact of portal improvement standards on the use of motorcoach portals as a means of emergency egress. See *id.*

tentatively concludes that these requirements are necessary to ensure that these emergency exits are operable after being exposed to the racking forces of rollover crashes.

Note that we have tentatively concluded not to apply the above requirements (that the emergency exits be operable as required under FMVSS No. 217) to side emergency exit windows. A requirement that window exits facing the impact surface must open upon application of the FMVSS No. 217 forces would not make sense, since the exits are face-down on the ground. A requirement that window exits facing the sky on the opposite side of the impact surface must open as directed by FMVSS No. 217 might not be achievable with the vehicle on its side because of the mass of the window glazing and the effect of gravity.

**g. Side Window Glazing**

NHTSA proposes that, after the rollover structural integrity test, each window glazing opposite the impacted side of the vehicle shall not detach from its mounting. The purpose of the requirement is to ensure that the vehicle's structural integrity will prevent heavy glazing panels from falling into the passenger compartment and becoming ejection portals. As with our discussion of emergency exits (above), this proposed requirement to enhance side window glazing retention through structural integrity is part of NHTSA's consideration of countermeasures that would help prevent partial and complete ejection of motorcoach passengers (pursuant to the provisions in MAP-21<sup>61</sup>). NHTSA would assess compliance with this requirement by requiring that the side window opening not

---

<sup>61</sup> As described above, MAP-21 directs the agency to establish improved roof and roof support standards (in section 32703(b)(1)) and consider glazing and other portal improvements to prevent partial and complete ejection of passengers (in section 32703(b)(2)).

allow the passage of a 102 mm diameter sphere when a force of no more than 22 Newtons (N) is applied at any vector towards the exterior of the vehicle.

Our test of the MY 2000 45-foot MCI bus demonstrated that side window glazing can detach during the rollover structural integrity test and collapse into the passenger compartment. Based on an assessment conducted in the agency's research to enhance emergency evacuation (the third action item in NHTSA's 2007 Approach to Motorcoach Safety), side windows in buses can weigh as much as 84 kg (185 lb).<sup>62</sup> We are concerned that increasingly massive glazing panels are increasingly difficult to retain in the mounting structure in a crash. Because the rollover structural integrity test proposed today simulates significant racking forces which can deform the window glazing mounts, we believe that adopting a test that in effect determines if the glazing remained in its mounting structure will lead to increased structural integrity on these vehicles, and a reduced risk of injury from falling panels of glazing and occupant ejections.

The 102 mm (4 in) performance limit is used in FMVSS No. 217, "Bus emergency exits and window retention and release," (49 CFR 571.217). Under that standard, in order to minimize the likelihood of occupant ejection, bus manufacturers are required to ensure that when a force is applied to the window glazing as specified in that standard, each piece of glazing and each piece of window frame be retained by its surrounding structure in a manner that prevents the formation of any opening large enough to admit the passage of a 102 mm diameter sphere under a 22 N (5 lb) force.

We tentatively conclude that the FMVSS No. 217 specification for assessing integrity of the window, based on passage of a 102 mm diameter sphere (and a force

---

<sup>62</sup> Human Factors Issues in Motorcoach Emergency Egress INTERIM REPORT 1- FINAL; John A. Volpe National Transportation Systems Center, Research and Innovative Technology Administration, August 2009. Docket No. NHTSA-2007-28793.

application of 22 N), is appropriate to test for window glazing remaining securely attached to its mounting at the conclusion of today's proposed test. The agency tentatively concludes that the proposed requirement specifies a minimum level of performance that better ensures that side window glazing and their mountings can withstand the racking forces associated with a rollover. As a result, occupants will be better protected from heavy window glazing that may collapse into the survival space, and from risk of ejections.

We note that section 32703(b)(2) in MAP-21 also directs the agency (when considering portal improvements that can help prevent occupant ejection) to also consider the impact of such improvements on emergency egress. We are not currently aware of any data that show that the improvements to window mounting (proposed in this section) will have a detrimental impact on emergency egress. We are not aware of any large bus fatalities that were caused by non-functioning or unavailable emergency exits (i.e., trapping occupants inside the bus).<sup>63</sup> On the other hand, the data clearly show a high correlation between occupant ejection and occupant fatality. The data also show that window glazing can become dismounted during a rollover crash and fall into the survival space where bus occupants will be. Thus, we tentatively conclude that the proposed improvements to window glazing mounting can address significant safety concerns and are unlikely to produce any substantial negative impact on safety. We request comment on this tentative conclusion and whether there are any data/cases that show that

---

<sup>63</sup> However, as discussed in the section prior, we do propose to require that emergency exits will operate as specified under FMVSS No. 217 after being exposed to the crash conditions of the proposed test. We believe that this proposed requirement would also help alleviate any concerns that large bus occupants might be trapped in the vehicle after a crash without forgoing the important benefits of preventing occupant ejections and window glazing intrusions into the survival space.

improving side window mounting would lead to a negative safety impact outweighing the aforementioned safety benefits.

## **VI. Regulatory Alternatives**

In deciding on the approach proposed in this NPRM, NHTSA has examined the following alternatives to this proposal.

### **a. FMVSS No. 216**

NHTSA considered the requirements of FMVSS No. 216, “Roof crush resistance.” FMVSS No. 216 applies to vehicles with a GVWR of 4,536 kg (10,000 lb) or less, and specifies a test that applies localized static loads to the front of the vehicle. Unlike passenger vehicles, the large buses that we propose to cover under today’s NPRM are larger/heavier and are more likely to roll than yaw. As a result, in a rollover involving one of these vehicles, the entire length of the vehicle is loaded as in the ECE R.66 test. Therefore, the ECE R.66 test is more representative than the FMVSS No. 216 test since it imparts loads along the full length of the vehicle. In addition, the ECE R.66 is a dynamic test where additional safety issues specific to the vehicles covered by this rulemaking (opening of emergency exits, failure of seat and overhead luggage rack anchorages, and detachment of windows from their mountings) can be evaluated. This is not possible in the FMVSS No. 216 test since it is a quasi-static test. Since two-thirds of rollover fatalities are due to ejections, addressing these additional safety issues is critical to addressing the safety problem in rollovers. Therefore, the agency believes that the ECE R.66 test is a better representation of a large bus rollover crash than the FMVSS No. 216 test. Thus, the agency has tentatively chosen not to include a test based on FMVSS No. 216 in today’s NPRM.

### **b. FMVSS No. 220**

FMVSS No. 220 is a school bus roof crush standard which places a uniformly distributed vertical force pushing directly downward on the top of the bus with a platen that is 914 mm (36 inches) wide and that is 305 mm (12 inches) shorter than the length of the bus roof. The standard specifies that when a uniformly distributed load equal to 1.5 times the unloaded vehicle weight is applied to the roof of the vehicle's body structure through a force application plate, the downward vertical movement at any point on the application plate shall not exceed 130 mm (5.125 inches) and the emergency exits must be operable during and after the test.

The agency included FMVSS No. 220 in its research into rollover structural integrity for large buses. However, we have tentatively decided to propose a test based on ECE R.66 rather than a test based on FMVSS No. 220 for several reasons. First, the agency believes that an ECE R.66 based test is more suitable for the vehicles covered by this proposed rule than an FMVSS No. 220 based test because a significant portion of fatalities in these rollovers result from occupant ejections. Unlike school buses, these large buses operating intercity routes typically travel at higher speeds than school buses transporting children to a local educational facility. Further, many of these buses are designed such that they have a higher center of gravity than school buses and utilize larger windows. These characteristics can lead to a higher incidence of occupant ejections during rollovers involving these types of buses. Thus, the dynamic rollover test in ECE R.66 affords the agency the opportunity to better evaluate ejection mitigating factors such as the emergency exits and side window glazing retention during a rollover crash.

In addition, the vehicles covered by this proposed rule generally have more interior fixtures (such as luggage racks) than school buses and the data show that such

interior fixtures have, at times, failed and created dangerous conditions. Again, the dynamic nature of the ECE R.66 protocol provides an opportunity to assess the strength of these internal fixtures, which have been identified as a safety concern in these types of vehicles.

Second, ECE R.66 is an existing test, designed specifically to evaluate the performance of this vehicle type in rollover crashes. NHTSA has greater assurance (than with an FMVSS No. 220 based test) that this proposed standard can be applied to the large buses covered by today's proposal. Further, by basing our proposed test on ECE R.66, we believe that manufacturer familiarity with the proposed standard would help reduce many uncertainties in compliance. In addition, in the absence of data showing ECE R.66 should be preferred less than an alternative, the ECE R.66 based test proposed by today's NPRM is also merited because it allows the agency to further its harmonization efforts with the European Union.

Due to these differentiating characteristics, the agency believes that ECE R.66 is more suited than FMVSS No. 220 for evaluating rollover structural integrity in the large bus types covered by today's proposal. Since FMVSS No. 220 is a quasi-static test, it also does not address the additional safety issues specific to these bus types. While FMVSS No. 220 has a proven record of ensuring rollover safety in school buses, it was not designed for the purpose of evaluating rollover crash performance of the buses that are the subject of today's proposal. Therefore, today's NPRM proposes a test based on ECE R.66.

### **c. ECE R.66 Alternative Compliance Methods**

The proposed test in today's NPRM is based on the complete vehicle test from ECE R.66. In addition to the complete vehicle test, ECE R.66 provides manufacturers

four alternative options for complying with ECE R.66 requirements.<sup>64</sup> The following options are considered by ECE R.66 to be equivalent approval tests: (1) rollover structural integrity test of body sections representative of the vehicle, (2) quasi-static loading tests of body sections, (3) quasi-static calculations based on testing of components, and (4) computer simulation (finite element analysis) of complete vehicle.<sup>65</sup>

The agency has considered these alternative compliance methods but has determined they would not be practical for the agency's compliance testing.

We have tentatively determined that Alternatives 1 and 2 would not be practical for use by the agency as they would not achieve the goals of this rulemaking. These alternative methods test body sections of the vehicle. The alternatives pose compliance difficulties. If NHTSA were to use Alternatives 1 and 2, the agency would likely have to acquire materials and information supplied from the manufacturers, or "section" the vehicle ourselves, which is impractical. Alternatives 1 and 2 require that the body-sections be representative of the entire vehicle. Determining the representativeness of a body-section would require input and analysis from the manufacturer, and even with that, determining what is "representative" could be subjective and difficult for NHTSA to verify. (E.g., is the center of gravity of the body section representative of the whole vehicle?) Also, testing an entire vehicle rather than body sections is preferable to us

---

<sup>64</sup> There are significant differences in the manner in which a manufacturer demonstrates compliance with safety regulations in European Union and in the United States. In Europe, European governments use "type approval," which means that they approve particular designs as complying with their safety standards. In the U.S., NHTSA issues performance standards, to which manufacturers self-certify that their vehicles or equipment comply. NHTSA does not pre-approve vehicles or equipment before sale. Under the National Traffic and Motor Vehicle Safety Act, the FMVSSs must be objective, repeatable, and meet certain other statutory criteria. NHTSA enforces the FMVSSs by obtaining vehicles and equipment for sale and testing them to the procedures specified in the FMVSSs.

<sup>65</sup> Further information regarding the alternative certification methods of ECE R.66 is available at: Motorcoach Roof Crush/Rollover Testing Discussion Paper, March 2009, Docket No. NHTSA-2007-28793-0019.



because it would better ensure the assessment of all body sections, including representative as well as worse-case (weakest) sections of the bus. Also, if manufacturers were to provide the test specimens, a more conscientious effort might be taken by them to manufacture the specimen, and so the specimen might not be representative of the typical, mass produced bus. Thus, we prefer not to involve manufacturer-supplied body sections in NHTSA's compliance test.

Alternatives 3 and 4, above, would not be suitable for incorporation into the FMVSS for NHTSA's compliance testing because they may not be sufficiently objective. NHTSA is directed to issue performance standards,<sup>66</sup> the compliance with which must be measured objectively.<sup>67</sup> Assessing compliance using calculations and extrapolations or computer simulations introduces an element of subjectivity into the compliance process. A manufacturer might believe that its vehicle met the structural integrity requirements based on its calculations and computer simulations, while someone else might not agree that the assumptions made in the calculations or on which the simulations were based were appropriate or correct for demonstrating compliance in the particular instance. While a manufacturer may have the knowledge of the materials and joint structure for their vehicles to be able to make a more accurate model, an external entity may not be able to easily reproduce these results. The variability of assumptions in such models makes this method unsuitable for use by NHTSA in evaluating compliance with an FMVSS. For example, for Alternative 3, we would need to identify the location of the plastic zones and plastic hinges as well as estimate their load-deformation curves. For

---

<sup>66</sup> In 49 U.S.C. § 30102, the National Traffic and Motor Vehicle Safety Act defines "motor vehicle safety" as the "performance" of motor vehicles or motor vehicle equipment in a way such as to avoid creating an unreasonable risk of accident to the general public. The same Act defines "motor vehicle safety standards" as minimum standards for motor vehicle or motor vehicle equipment "performance."

<sup>67</sup> In 49 U.S.C. § 30111 (a), the National Traffic and Motor Vehicle Safety Act requires that Federal motor vehicle safety standards be stated in objective terms.

Alternative 4, mathematical models that simulate accurately the actual rollover crash of the vehicle are required.

Moreover, basing compliance on calculations and computer simulations does not take into account any differences that may occur between the analytical model and the vehicle as manufactured. Because they do not utilize an actual vehicle, these approaches do not account for variation or flaws in material properties, or defects or errors in the manufacturing build processes. In contrast, NHTSA prefers to test actually-manufactured vehicles, to assess not only the design of the vehicle but the real-world manufacturing processes as well.

For these reasons, today's NPRM is based on the complete vehicle test of ECE R.66 and does not provide for NHTSA's use of Alternatives 1 through 4 to determine compliance.

**d. Comments Requested on Alternative Levels of Stringency**

As stated above, we believe that the ECE R.66 test is the most appropriate test for addressing the safety concerns related to the large buses covered under this NPRM. However, we request comment on potential alternative levels of stringency that could be used with this test. In this NPRM, we propose to use essentially the same survival space requirements as in ECE R.66. The agency is aware of research that supports the stringency levels adopted by ECE R.66<sup>68</sup> and (absent any data to the contrary) the agency

---

<sup>68</sup> A 2007 paper by Matolcsy reported on different types of rollover tests and a comparison of these tests to real world bus rollover events. The type of tests considered were a bus rolled down a 5.5 to 9 meter high embankment with two different grades (which would result multiple rolls of the bus) and the ECE R.66 type tip-over test from an 800 mm platform on to a concrete surface (proposed in this document). Matolcsy found that the loads on the superstructure in the ECE R.66 were greater than those in the rollover tests down various grades of embankments. A reinforced bus superstructure that maintained its occupant survival space in the rollover test down a steep embankment performed poorly in the ECE R.66 test and needed further reinforcement. Matolcsy also presented real world rollover accidents involving buses designed to comply with ECE R.66 requirements and where the occupant survival space was not

believes that there is value in adopting a standard that is as harmonized with the EU as possible.

Thus, while we propose to adopt the survival space requirements specified in this document (which are essentially the ECE R.66 requirements) we request comment on whether there is any data to indicate what the marginal benefits and costs would be for increasing or decreasing the survival space requirements. In other words, what other potential levels of stringency could the agency consider (i.e., larger or smaller survival spaces) and what data would support choosing that level of stringency? What would the safety impact be for that different level of stringency and how would the costs be different? What other types of adjustments in stringency should the agency consider? For example, should the agency consider adjusting the height of the platform used to tilt the bus during the test? This type of change could increase or decrease the severity of the bus' impact during the test.

In addition, we note that our proposal includes additional performance requirements on the integrity of the luggage racks, seats, and window glazing attachments. As we stated, we believe these requirements are complementary to the survival space requirements. However, we acknowledge that these requirements make the proposal slightly more stringent than the ECE R.66 requirements. These additional performance requirements were included in the proposal because of observed failures of bus components that resulted in occupant injuries in real world bus rollover crashes or had the potential for injuring occupants. We seek comment on these additional

---

compromised. In one such accident, the ECE R.66 compliant bus rolled down a 9-10 meter high embankment with a 30-35 degree grade and completed 2 and 1/4 turns without compromising its survival space. See Matolcsy, M., "The Severity of Bus Rollover Accidents," Scientific Society of Mechanical Engineers., ESV Proceedings, Lyon, France, Paper No. 07-0989, available at <http://www-nrd.nhtsa.dot.gov/pdf/esv/esv20/07-0152-O.pdf>.

performance requirements in the proposal over those specified in ECE R.66. Are there additional requirements that the agency should consider for this test? We also seek comment on whether the agency should remove these additional performance requirements from the proposal and thereby making the test slightly less stringent.

## **VII. Other Issues**

### **a. Retrofitting**

The Secretary of Transportation has authority to promulgate safety standards for “commercial motor vehicles and equipment subsequent to initial manufacture.”<sup>69</sup> The Office of the Secretary has delegated authority to NHTSA to “promulgate safety standards for commercial motor vehicles and equipment subsequent to initial manufacture when the standards are based upon and similar to a [FMVSS] promulgated, either simultaneously or previously, under chapter 301 of title 49, U.S.C.”<sup>70</sup> Further, §32703(e)(2) of MAP-21 states that the “Secretary may assess the feasibility, benefits, and costs with respect to the application of any requirement established under subsection . . . (b)(2) to motorcoaches manufactured before the date on which the requirement applies to new motorcoaches.”<sup>71</sup> Subsection (b)(2) directs the agency to consider portal improvements to prevent partial and complete ejection of motorcoach passengers.

Based on our testing of the MY 1991 Prevost and the MY 1992 MCI buses, the agency believes that major structural changes to the vehicle’s entire sidewall and roof structure would be needed for some existing buses to meet the rollover structural integrity

---

<sup>69</sup> Under Sec. 101(f) of Motor Carrier Safety Improvement Act of 1999 (Public Law 106-159; Dec. 9, 1999).

<sup>70</sup> See 49 CFR§ 1.95(c). Additionally, the Federal Motor Carrier Safety Administration (FMCSA) is authorized to enforce the safety standards applicable to commercial vehicles operating in the U.S.

<sup>71</sup> See Moving Ahead for Progress in the 21<sup>st</sup> Century Act, Pub. L. No. 112-141, § 32703(e)(2). Section 32703(e)(2)(B) states that the Secretary shall submit a report on the assessment to Congress not later than 2 years after date of enactment of the Act.

requirements proposed in today's NPRM. The agency is concerned that such extensive modifications may not be possible on all existing vehicles that would be covered by this proposed rule if the scope were expanded to include retrofitting requirements. In addition, we expect these major structural changes to carry significant additional costs beyond those estimated in our regulatory analysis, and possibly have a substantial impact on a significant number of small entities (e.g., owner-operators of large buses used for transport).

In regards to the proposed requirements for side window glazing retention and emergency exits, the agency also believes that major structural changes would be necessary to ensure a comparable level of performance (when compared to a new large bus manufactured to meet today's proposed requirements). As emergency exits and side window glazing can create ejection portals during a rollover crash due to the structural deformation that can occur during a crash, the extensive modifications to the bus structure that would be necessary for enhanced side window glazing retention and emergency exit performance may also not be possible. Thus, the agency has tentatively concluded that requiring retrofitting of existing buses would be impracticable and NHTSA has tentatively decided not to include retrofitting requirements in today's NPRM.

The agency seeks comment on these tentative conclusions. The agency notes that the service life of a bus can be 20 years or longer and that it is possible that the cost of retrofitting can vary substantially depending on the requirements being applied to used buses and the countermeasures available. Further, we note that the proposed "complete vehicle" test of ECE R.66 is unlikely suitable for evaluating compliance with any requirements applied to used buses (as ECE R.66 is a destructive test).

Thus, the agency seeks information on the technical and economic feasibility of a potential retrofit requirement. Which requirements in today's proposal could be appropriately applied to used buses? What potential test procedures could the agency utilize to objectively measure compliance? Would it be reasonable to assess compliance with a retrofit requirement by means of only visually inspecting the vehicle? What lead time and phase-in issues should the agency consider for a potential retrofit requirement? What would the potential costs be?

**b. Lead Time**

If the proposed changes in this NPRM are made final, NHTSA is proposing a compliance date of three years after publication of a final rule. MAP-21 (in § 32703(e)) directs the agency to apply regulations prescribed in accordance with § 32703(b) "to all motorcoaches manufactured more than 3 years after the date on which the regulation is published as a final rule." We believe that a three-year lead time after publication of final rule is appropriate as some design, testing, and development will be necessary to certify compliance to the new requirements.

Based on our research, the agency believes that manufacturers may need to make structural design changes to their new models either by changing the strength of the material or the physical dimensions of the material. In addition, the manufacturers may need to strengthen the seat and luggage rack anchorage methods, improve the type of latches used on emergency exits, and improve the mounting of side windows. Thus, the agency tentatively concludes that three years of lead time would be needed to enable manufacturers to make the necessary changes.

To enable manufacturers to certify to the new requirements as early as possible, optional early compliance with the standard would be permitted.

**c. Additional MAP-21 Considerations**

In addition to the aforementioned MAP-21 provisions, MAP-21 also directs the agency to consider the best available science, potential impacts on seating capacity, and potential impacts on the size/weight of motorcoaches.<sup>72</sup> Further, MAP-21 directs the agency to consider combining the various motorcoach rulemakings contemplated by MAP-21 and to avoid duplicative benefits, costs, and countermeasures.<sup>73</sup>

NHTSA has considered the best available science in developing today's NPRM. Regarding any potential impacts on seating capacity, the agency currently does not believe that the requirements proposed in today's NPRM will require structural reinforcements at the expense of seating capacity. However, the agency requests comment on this issue.

Through today's NPRM and its accompanying Preliminary Regulatory Evaluation (PRE), the agency is considering potential impacts on the size and weight of motorcoaches (and other large buses that would be affected by the proposed rule).<sup>74</sup> As described further in section VIII, *infra*, (and in the PRE) the agency has considered potential weight increase to motorcoaches as a potential cost of this proposed rule (due to increased fuel consumption). In the accompanying PRE, we have attempted to quantify and account for this potential cost (of increased fuel consumption) in our cost-benefit analysis of the rule. After considering all costs (including the potential weight increase), the agency tentatively believes that the proposed requirements in today's NPRM would be cost-beneficial.

---

<sup>72</sup> See Moving Ahead for Progress in the 21<sup>st</sup> Century Act, Pub. L. No. 112-141, § 32703(e)(1).

<sup>73</sup> See *id.* at § 32706(b)-(c).

<sup>74</sup> "Motorcoach" in this paragraph has the meaning given in MAP-21 (over-the-road buses).

Further, the agency is considering combining the rulemakings contemplated by MAP-21 and avoiding the duplication of benefits/costs/countermeasures in today's NPRM. As mentioned above, the agency believes that the proposed test (based on ECE R.66) can be used not only to evaluate the structural integrity of a large bus (such as an over-the-road bus) but also to evaluate the strength of its structural integrity in supporting side window glazing retention and emergency exit latches. As NHTSA's research on various motorcoach models showed that (during a rollover crash) side window glazings have the potential to become dislodged and emergency exits have the potential to open, NHTSA tentatively believes that the proposed ECE R.66-based test can be used to address at least part of Congress's concerns under § 32703(b)(2) (anti-ejection safety) in addition to the concerns under § 32703(b)(1) (roof strength). Thus, the agency is combining these two aspects of MAP-21 into this rulemaking proceeding.

Finally, NHTSA is avoiding the duplication of benefits, costs, and countermeasures in today's rulemaking proceeding with other potential NHTSA rules being considered pursuant to MAP-21. The agency does not believe that potential countermeasure used to meet the proposed requirements of today's NPRM would be duplicative of other rules. As described above, the agency believes that the potential requirements in today's NPRM would work hand-in-hand with the agency's final rule on seat belts. As described below in section VIII, infra, and the accompanying PRE, the agency is expressly considering the estimated costs and benefits of the final rule requiring seat belts on the large buses. The agency is not attributing the estimated costs and benefits of the final rule on seat belts to this rulemaking proceeding on structural integrity.



In sum, we have issued today's NPRM after careful deliberation of the factors emphasized for consideration in MAP-21, which we note are also factors NHTSA routinely investigates carefully when the agency conducts rulemaking under the Motor Vehicle Safety Act.

### **VIII. Overview of Costs and Benefits**

Based on the FARS data over the ten year period between 2000 and 2009, there were a total of 32 fatal rollover crashes involving the large bus types covered by this proposal, resulting in 114 occupant fatalities. Beyond the benefits attributable to the rule on seat belts for these vehicles and a possible rulemaking on electronic stability control systems,<sup>75</sup> the agency estimates that today's proposed rule would save approximately 3.1 equivalent lives annually if 15 percent of occupants use seat belts, and approximately 2.3 equivalent lives annually if 84 percent of occupants use seat belts.<sup>76</sup>

While occupants that are belted will benefit from increased structural integrity, the agency believes that unbelted occupants will receive additional protection as well.

The proposed rulemaking will offer the unbelted occupant additional protection through

---

<sup>75</sup> As we further discuss in the PRE supporting today's NPRM, we adjusted the target population based on the projected benefits that would be attributable to those rules. Separately, we also considered whether there have been any recent FMCSA actions which might affect the projected target population and we have tentatively concluded that they would not. FMCSA has issued several recent final rules directed at bus and truck safety, including Medical Certificate Requirements as Part of the Commercial Driver's License in 2008, Drivers of Commercial Vehicles: Restricting the Use of Cellular Phones in 2011, Hours of Service in 2011, and National Registry of Certified Medical Examiners in 2012. In addition, FMCSA has had several recent enforcement efforts to improve bus safety, including several nationwide "Strike Force" enforcement events. The agency has consulted with FMCSA and does not believe that the benefits estimated in this NPRM overlap with the benefits contained in recent FMCSA actions associated with bus safety.

<sup>76</sup> The PRE prepared in support of today's NPRM assumes that the seat belt use rate on motorcoaches would be between 15 percent, and the percent use in passenger vehicles, which was 84 percent in 2009. In order to maintain consistency with the agency's rule to require seat belts on motorcoaches, we have utilized the same low belt usage rate estimate of 15% from that rule. *See* Final Regulatory Impact Analysis – FMVSS No. 208. We have also utilized the same source of information to establish the high belt usage rate estimate (the National Occupant Protection Use Survey). Today's NPRM uses the 2009 data which estimates seat belt use of passenger vehicles to be 84%. *See* 2009 National Occupant Protection Use Survey. More information at: <http://www-nrd.nhtsa.dot.gov/pubs/811100.pdf>.

reduced risk of ejection. The belted occupant will most likely benefit mainly from reduced intrusion, and seats remaining secured. Given these potential differences in effectiveness of structural improvements for belted and unbelted occupants, the agency has estimated benefits for each group separately.

The benefits estimates also vary by seat belt use. Available research regarding seat belt use suggests that it can be highly variable and the agency has estimated the lower end of seat belt use at 15 percent and the upper end of seat belt use to be consistent with that of passenger vehicles, at 84 percent. In spite of this, the agency expects belt use, initially, to be closer to the lower end (of 15%) in part because many passengers are not accustomed to using seat belts on these vehicles due to the current lack of availability of belts in these vehicles and the fact that passengers have not yet been educated regarding the benefits of buckling up in a large bus.

Thus, we estimate that the proposed rule would reduce the number of seriously injured occupants by approximately 4 annually. We estimate that 3.1 equivalent lives are saved annually if 15 percent of occupants use seat belts, and approximately 2.3 equivalent lives are saved annually if 84 percent of occupants use seat belts (see Table 6 below).

The agency estimates that, assuming steel is used to comply with the proposed requirements in this rule, material costs for each vehicle will range from \$282 to \$507 and cost between \$0.6 million and \$1.1 million to equip the entire new large bus fleet annually (see Table 7 below). We further estimate that, if steel is used to comply, the total weight increase will range from 564 to 1,114 lb and cost an additional \$2,118 to \$5,523 in fuel per vehicle over the lifetime of the vehicle. The total fuel cost for the new fleet is estimated to be \$4.7 million to \$12.2 million. The total costs would be

approximately \$5.3 million to \$13.3 million annually. The cost per equivalent life saved is estimated to be between \$2.09 million and \$6.42 million (see Table 8 below).

All the available information indicates that this proposed rule—if made final—would be cost beneficial. Further, the agency anticipates that the projected net impact on the economy will be closer to the estimates for the 15% belt use rates than the 84% belt use rate. We note that the above estimates for the cost per equivalent life of this rule vary due to uncertainties regarding seat belt use rates and the incremental increase in weight that is necessary to meet today's proposed structural integrity standard. A large portion of the costs of this structural integrity rule is dependent on this incremental increase in weight. While the agency does not have more specific information regarding the likely weight increase to these vehicles, the agency does believe that seat belt usage rates will be closer to 15% rather than 84% because these vehicles are currently not equipped with seat belts and passengers have not yet been educated regarding the advantages of buckling up during travel on these vehicles. Thus, we anticipate that the proposed rule—if made final—would have a net beneficial impact on the economy that is closer to our estimates assuming a 15% belt use rate.

In addition to our expectation that this proposed rule would be cost beneficial, the agency believes that the cost effectiveness of this proposed rule is not very sensitive to changes in belt usage rates because belted passengers will still realize safety benefits as a result of this rule. Many serious injuries that occur in large bus crashes can occur despite a passenger's use of a safety belt. For example, while a belted passenger may not be ejected, he or she can still be struck by the collapsing side wall of the bus. Therefore, even though increasing belt usage rates may mean that more passenger ejections (and fatalities) will be prevented by seat belts (consequently reducing the number of prevented

ejections attributable to structural changes), the proposed requirements in this NPRM will still be effective in preventing serious injuries to belted passengers. Thus, we expect that the monetized value of the benefits of this proposed rule is not very sensitive to fluctuations in belt use—even though the type of benefit will change.<sup>77</sup>

**Table 6: Estimated Annual Benefits  
(Undiscounted Equivalent Lives Saved)**

15 percent belt usage	3.09
84 percent belt usage	2.31

**Table 7: Estimated Annual Costs  
(2010 Dollars)**

<b>Potential Costs</b>	
Material Costs Per Vehicle	\$282 to \$507
Material Costs, Total New Fleet	\$0.6 million to \$1.1 million
Fuel Costs per Vehicle @ 3%	\$2,814 to \$5,523
Fuel Costs per Vehicle @ 7%	\$2,118 to \$4,156
Fuel Costs, Total New Fleet	\$4.7 million to \$12.2 million
<b>Total Annual Cost</b>	<b>\$5.3 million to \$13.3 million</b>

**Table 8: Cost per Equivalent Life Saved  
(Across 3% and 7% Discount, 2010 Dollars)**

15 percent belt usage	\$2.09 million to \$4.72 million
84 percent belt usage	\$2.91 million to \$6.42 million

The cost of reinforcing the roof strength and structural integrity of these vehicles to meet the requirements proposed in this standard would be predominantly dependent upon the material and weight increases necessary to reinforce the superstructure. We estimate that the countermeasures may include stronger roof and side walls, shock

<sup>77</sup> For further information, please reference the Preliminary Regulatory Evaluation prepared in support of this NPRM.

resistant latches for emergency exits, stronger seat and luggage rack anchorages, and improved window mounting. As mentioned above, these material costs for each vehicle are estimated to be between \$282 and \$507. However, while the agency assumes in these estimates that steel is applied to reinforce the vehicle structure, the agency is aware that other methods of reinforcing the structure (such as the use of high strength steel sections, rigid polyurethane foam filling to reinforce and stabilize thin walled hollow sections, and optimized designs that redistribute the impact loads and enhance the energy absorption capability) may enable a vehicle to withstand greater crash forces without adding as much weight.<sup>78</sup> Therefore, while our analysis has assumed the use of steel, the agency is aware that there may be other countermeasures that weigh less—which could result in lower fuel costs (than we have currently estimated) over the lifetime of the vehicle.

The agency also notes that, in addition to the quantifiable benefits mentioned above, there are certain unquantifiable benefits that can arise from today's proposed rule. Our economic analysis of this proposed rule is only able to calculate the benefits that can be realized in addition to the benefits attributable to proposed rules requiring seat belts and electronic stability control systems. In other words, we are only able to estimate the benefits to passengers whose serious and fatal injuries were not prevented by seat belts. When a passenger that would have been fatally injured due to an ejection is estimated as saved by the use of a seat belt that prevents the ejection, we can no longer estimate additional benefits for that particular passenger.

---

<sup>78</sup> See Lilley, K. and Mani, A., "Roof-Crush Strength Improvement Using Rigid Polyurethane Foam," SAE Technical Paper 960435, 1996. Available at: <http://subscriptions.sae.org/content/960435/>, see also Liang, C. and Le, G. Optimization of bus rollover strength by consideration of the energy absorption ability. International Journal of Automotive Technology. Vol. 11.(2) 173 – 185. Available at: <http://www.springerlink.com/content/tk824863k66w0228/export-citation/>.

However, we note that while a fatal ejection may be prevented by the use of seat belts, it is possible that poor structural integrity could still contribute towards an injury for this occupant. The type of injury that can occur to this occupant (fatal ejection prevented by seat belts but still seriously injured by collapsing structure intruding into the survival space) is similar to our earlier discussion regarding the benefits to belted passengers. However, it is important to note that while the agency was able to estimate benefits to belted passengers whose serious injuries and fatalities were not prevented by the seat belts, the agency is unable to estimate what additional (potential) benefits may be realized by those passengers who have already realized benefits because they were no longer fatally injured in an ejection due to seat belt use. As the agency is unaware of any available information that would permit the agency to quantify this benefit, the agency's economic analysis of this proposed rule only estimates the benefits to occupants that would not have been protected by the use of seat belts.

For further information regarding the aforementioned cost and benefit estimates, please reference the PRE that NHTSA has prepared and placed in the Docket.<sup>79</sup>

We have tentatively decided not to include retrofitting requirements at this time to require that used buses be retrofitted to meet the rollover structural integrity requirements. The service life of a large bus can be 20 years or longer. It may not be structurally viable to retrofit many of the used large buses that are currently in service. Also, it may not be economically feasible for many for-hire operators (many of which are

---

<sup>79</sup> The PRE discusses issues relating to the potential costs, benefits and other impacts of this regulatory action. The PRE is available in the docket for this NPRM and may be obtained by downloading it or by contacting Docket Management at the address or telephone number provided at the beginning of this document.

small businesses) to fund the necessary structural changes. Thus, we have not included the costs of retrofitting in our analysis of the costs and benefits of the proposed rule.

## **IX. Regulatory Analyses**

### Executive Order 12866, Executive Order 13563, and DOT Regulatory Policies and Procedures

NHTSA has considered the impact of this rulemaking action under Executive Order 12866, Executive Order 13563, and the Department of Transportation's regulatory policies and procedures (44 FR 11034; February 26, 1979). This NPRM is "significant" and was reviewed under the Executive Order. NHTSA has prepared a PRE for this NPRM.

This NPRM proposes to increase roof strength and structural integrity for certain large bus types by establishing requirements for maintaining survival space, seat and overhead luggage rack retention, emergency exit operability, and window mounting strength during a rollover structural integrity test. This NPRM proposes a test procedure which tilts the vehicle on a platform until the vehicle becomes unstable and rolls over onto a level concrete impact surface.

Beyond the benefits attributable to the rule on seat belts for this same group of vehicles and a possible rulemaking on electronic stability control systems, we estimate that requiring new large buses of these types to meet the aforementioned performance criteria would save approximately 3.1 equivalent lives annually if seat belt usage among occupants is 15 percent, and approximately 2.3 equivalent lives annually if seat belt usage is 84 percent. The total cost of making the necessary structural changes, and of lifetime fuel costs, would be approximately \$5.3 million to \$13.3 million annually (for the entire new fleet). The cost per equivalent life saved is estimated to be between \$2.09

million and \$6.42 million. The benefits, costs, and other impacts of this rulemaking are discussed at length in the PRE.

#### Executive Order 13609: Promoting International Regulatory Cooperation

The policy statement in section 1 of Executive Order 13609 provides, in part:

The regulatory approaches taken by foreign governments may differ from those taken by U.S. regulatory agencies to address similar issues. In some cases, the differences between the regulatory approaches of U.S. agencies and those of their foreign counterparts might not be necessary and might impair the ability of American businesses to export and compete internationally. In meeting shared challenges involving health, safety, labor, security, environmental, and other issues, international regulatory cooperation can identify approaches that are at least as protective as those that are or would be adopted in the absence of such cooperation. International regulatory cooperation can also reduce, eliminate, or prevent unnecessary differences in regulatory requirements.

As mentioned in the body of this preamble, the agency has considered regulatory approaches taken by foreign governments (namely, the European Union in ECE R.66) and decided to base its proposed rule on ECE R.66. In addition to the goal of reducing unnecessary differences in regulatory requirements between the U.S. and its trading partners, the agency has found the ECE R.66 test to be the most suitable test available for ensuring a minimum reasonable level of protection for passengers traveling in buses that are associated with the highest crash risk. While NHTSA has tentatively determined that it is not able to follow (in certain details) the entirety of the ECE R.66 test and requirements, the agency has explained its rationale for its proposed decisions in the relevant sections above.

#### Regulatory Flexibility Act

Pursuant to the Regulatory Flexibility Act (5 U.S.C. 601 et seq., as amended by the Small Business Regulatory Enforcement Fairness Act (SBREFA) of 1996), whenever an agency is required to publish a notice of rulemaking for any proposed or final rule, it must prepare and make available for public comment a regulatory flexibility analysis that



describes the effect of the rule on small entities (i.e., small businesses, small organizations, and small governmental jurisdictions). The Small Business Administration's regulations at 13 CFR Part 121 define a small business, in part, as a business entity "which operates primarily within the United States." (13 CFR §121.105(a)). No regulatory flexibility analysis is required if the head of an agency certifies that the rule will not have a significant economic impact on a substantial number of small entities. The SBREFA amended the Regulatory Flexibility Act to require Federal agencies to provide a statement of the factual basis for certifying that a rule will not have a significant economic impact on a substantial number of small entities.

NHTSA has considered the effects of this rulemaking action under the Regulatory Flexibility Act. According to 13 CFR § 121.201, the Small Business Administration's size standards regulations used to define small business concerns, manufacturers of the vehicles covered by this proposed rule would fall under North American Industry Classification System (NAICS) No. 336111, Automobile Manufacturing, which has a size standard of 1,000 employees or fewer. NHTSA estimates that there are 26 manufacturers of these types of vehicles in the United States (including manufacturers of motorcoaches, cutaway buses, second-stage motorcoaches, and other types of large buses covered by this proposal). Using the size standard of 1,000 employees or fewer, we estimate that approximately 10 of these 26 manufacturers would be considered a small business.

The agency does not believe that this proposed rule would have a significant economic impact on those small entities. First, the agency estimates that the incremental costs to each vehicle would be \$282 to \$507 per unit to meet the proposed rule. This incremental cost would not constitute a significant impact given that the average cost of

the vehicles covered by this proposed rule ranges from \$200,000 to \$400,000. Further, these incremental costs, which are very small compared to the overall cost of the vehicle, can ultimately be passed on to the purchaser and user.

In addition, the agency believes that certifying compliance with the proposed rule would not have a significant impact on the manufacturers. Small manufacturers have various options available that they may use in certifying compliance with the proposed standard. The economic impact of certifying compliance with the standard would not be significant. One option available to small entities is to certify compliance by using modeling and engineering analyses (such as a plastic hinge analysis of portal frames of the vehicle). ECE R.66 itself accounts for and accommodates this compliance option, and this approach has been used for years by European manufacturers in meeting ECE R.66. Thus, there are established practices and protocols that small manufacturers may use to avail themselves of this basis for certifying compliance with the standard.

We explained in Section VI., Regulatory Alternatives, that the aforementioned engineering analysis model would not be appropriate as the agency's method of assessing the compliance of vehicles with a Federal motor vehicle safety standard. However, manufacturers are not required to use NHTSA's test as the basis for their certification. While the agency's test defined in the proposed regulatory test would be an objective test capable of determining which vehicles meet the minimum requirements, manufacturers can use other methods (such as the alternative compliance options in ECE R.66) in certifying the compliance of their own vehicles. Unlike NHTSA, manufacturers certifying compliance of their own vehicles have more detailed information regarding their own vehicles and can use reasonable engineering analyses to determine whether

their vehicles will comply with the proposed requirements using alternative testing methods that may not be suitable for incorporation into an FMVSS.

Under the Motor Vehicle Safety Act, a manufacturer can avoid civil penalties associated with a noncompliance if it showed that it exercised due care in certifying its vehicles. A showing of due care can be based on engineering analyses, computer simulations, and the like, and NHTSA will assess the due care upon which the certification is made by evaluating, among other factors, the size of the manufacturer and its resources. We believe that a small manufacturer would be closely familiar with its vehicle design and would be able to utilize modeling and relevant analyses on a vehicle-by-vehicle basis to reasonably predict whether its design will meet the requirements of today's proposed rule.

Second, the small manufacturer could test body sections of the vehicle, as contemplated by ECE R.66, Alternatives 1 and 2. The manufacturer would be able to "section" the vehicle or otherwise obtain a body section representative of the vehicle and of the weakest section of the vehicle. It could base its certification on these tests, without testing a full vehicle.

Third, we note that in the event small manufacturers elect to conduct a test of a full vehicle, there are various methods available to reduce the costs of the test. One such method is by testing a vehicle which is not completely new. As the proposed requirements in today's NPRM pertain to structural integrity, we believe that a manufacturer could test the relevant body design on an old bus chassis or other underlying structure, and could sufficiently assess and certify the compliance of the vehicle's structural integrity to the proposed standard. Similarly, the agency believes that more costly portions of the vehicle (such as the engine and other portions of the

powertrain) could be replaced in a complete vehicle test of a bus with ballast equal to the weight of the absent components. The small manufacturer could base its certification on such testing, which do not involve a destructive test of an actual vehicle.

Fourth, we also note that the product cycle of these vehicles is significantly longer than other vehicle types. With a longer product cycle, we believe that the costs of certification for manufacturers would be further reduced as the costs of conducting compliance testing and the relevant analyses could be spread over a significantly longer period of time.

Finally, we note that the requirements in today's proposed rule may affect the operators of the buses that are the subject of today's NPRM—some of which may be small businesses—but only indirectly as purchasers of these vehicles. As mentioned above, we anticipate that the impact on these businesses will not be significant because (assuming that additional steel is used for compliance) the expected price increase of the vehicles used by these businesses is small (\$282 to \$507 for each vehicle valued between \$200,000 and \$400,000). Further, we anticipate that fuel costs for these businesses will increase between \$2,118 and \$5,523 (in 2009 dollars) per vehicle over its lifetime. These expected increases in costs are small in comparison to the cost of each of these vehicles. In addition, we anticipate that these costs will equally affect all operators and therefore we expect that small operators will be able to pass these costs onto their consumers.

For the aforementioned reasons, I hereby certify that if made final, this proposed rule would not have a significant economic impact on a substantial number of small entities.

With regard to a retrofit requirement applying to a population of on-road vehicles, the agency has tentatively concluded that requiring retrofitting of existing vehicles would

be impracticable and therefore has decided not to propose retrofitting requirements in today's NPRM. An estimated 78.8 percent of the 3,137 motorcoach carriers (according to the 2008 Motorcoach Census) in the United States in 2007 (i.e. about 2,470 carriers) have less than 10 motorcoaches in their fleet. Further, these companies have an average of three vehicles and eleven employees. While the vehicles included in the motorcoach census are not exactly the same as the vehicles covered in today's proposal, we believe the industry's Motorcoach Census offers a reasonable estimate of the proportion of bus carrier companies that would be affected as owners/operators of the buses covered in today's NPRM.

NHTSA tentatively believes that to include retrofit requirements would be a substantial burden on these small carriers. The service life of each of the vehicles covered under today's proposal can be as much as 20 years or longer. Further, it may not be structurally viable for many of these used large buses to be retrofitted. Thus, NHTSA has tentatively decided not to include such requirements in today's proposal that on-road large buses be retrofitted to meet the roof strength requirements of this proposed rule, but requests comments on the issue. The agency is also seeking comment as to whether the proposed emergency exit and side window glazing retention requirements should be applied to used buses.

#### Executive Order 13132 (Federalism)

NHTSA has examined today's proposed rule pursuant to Executive Order 13132 (64 FR 43255; Aug. 10, 1999) and concluded that no additional consultation with States, local governments, or their representatives is mandated beyond the rulemaking process. The agency has concluded that the rule does not have sufficient federalism implications to warrant consultation with State and local officials or the preparation of a federalism

summary impact statement. The rule does not have “substantial direct effects on the States, on the relationship between the national government and the States, or on the distribution of power and responsibilities among the various levels of government.”

NHTSA rules can have preemptive effect in two ways. First, the National Traffic and Motor Vehicle Safety Act contains an express preemption provision:

When a motor vehicle safety standard is in effect under this chapter, a State or a political subdivision of a State may prescribe or continue in effect a standard applicable to the same aspect of performance of a motor vehicle or motor vehicle equipment only if the standard is identical to the standard prescribed under this chapter. 49 U.S.C. § 30103(b)(1). It is this statutory command by Congress that preempts any non-identical State legislative and administrative law address the same aspect of performance.

The express preemption provision described above is subject to a savings clause under which “[c]ompliance with a motor vehicle safety standard prescribed under this chapter does not exempt a person from liability at common law.” 49 U.S.C. § 30103(e) Pursuant to this provision, State common law tort causes of action against motor vehicle manufacturers that might otherwise be preempted by the express preemption provision are generally preserved. However, the Supreme Court has recognized the possibility, in some instances, of implied preemption of State common law tort causes of action by virtue of NHTSA’s rules—even if not expressly preempted.

This second way that NHTSA rules can preempt is dependent upon the existence of an actual conflict between an FMVSS and the higher standard that would effectively be imposed on motor vehicle manufacturers if someone obtained a State common law tort judgment against the manufacturer—notwithstanding the manufacturer’s compliance with the NHTSA standard. Because most NHTSA standards established by an FMVSS

are minimum standards, a State common law tort cause of action that seeks to impose a higher standard on motor vehicle manufacturers will generally not be preempted. However, if and when such a conflict does exist - for example, when the standard at issue is both a minimum and a maximum standard - the State common law tort cause of action is impliedly preempted. See Geier v. American Honda Motor Co., 529 U.S. 861 (2000).

Pursuant to Executive Order 13132, NHTSA has considered whether this proposed rule could or should preempt State common law causes of action. The agency's ability to announce its conclusion regarding the preemptive effect of one of its rules reduces the likelihood that preemption will be an issue in any subsequent tort litigation.

To this end, the agency has examined the nature (e.g., the language and structure of the regulatory text) and objectives of today's proposed rule and does not foresee any potential State requirements that might conflict with it. NHTSA does not intend that this proposed rule preempt state tort law that would effectively impose a higher standard on motor vehicle manufacturers than that established by today's rule. Establishment of a higher standard by means of State tort law would not conflict with the standards proposed in this NPRM. Without any conflict, there could not be any implied preemption of a State common law tort cause of action.

#### National Environmental Policy Act

NHTSA has analyzed this NPRM for the purposes of the National Environmental Policy Act. The agency has determined that implementation of this action would not have any significant impact on the quality of the human environment.

#### Paperwork Reduction Act

Under the procedures established by the Paperwork Reduction Act of 1995, a person is not required to respond to a collection of information by a Federal agency unless the collection displays a valid OMB control number. This rulemaking would not establish any new information collection requirements.

#### National Technology Transfer and Advancement Act

Under the National Technology Transfer and Advancement Act of 1995 (NTTAA) (Public Law 104-113), “all Federal agencies and departments shall use technical standards that are developed or adopted by voluntary consensus standards bodies, using such technical standards as a means to carry out policy objectives or activities determined by the agencies and departments.” Voluntary consensus standards are technical standards (e.g., materials specifications, test methods, sampling procedures, and business practices) that are developed or adopted by voluntary consensus standards bodies, such as the Society of Automotive Engineers (SAE). The NTTAA directs this agency to provide Congress, through OMB, explanations when the agency decides not to use available and applicable voluntary consensus standards.

While the agency is not aware of any voluntary standards that exist regarding rollover structural integrity for the large buses contemplated in today’s proposed rule, the agency has examined the applicable European Union standard (ECE R.66). As discussed extensively above, we have proposed in this NPRM to adopt an ECE R.66-based test, in part, to avoid requiring manufacturers to meet fundamentally different rollover requirements than those required in the European Union. The areas of today’s proposed rule which differ from ECE R.66, and the reasons in support, are extensively discussed in the earlier sections of this preamble.

#### Executive Order 12988



With respect to the review of the promulgation of a new regulation, section 3(b) of Executive Order 12988, “Civil Justice Reform” (61 FR 4729, February 7, 1996) requires that Executive agencies make every reasonable effort to ensure that the regulation: (1) Clearly specifies the preemptive effect; (2) clearly specifies the effect on existing Federal law or regulation; (3) provides a clear legal standard for affected conduct, while promoting simplification and burden reduction; (4) clearly specifies the retroactive effect, if any; (5) adequately defines key terms; and (6) addresses other important issues affecting clarity and general draftsmanship under any guidelines issued by the Attorney General. This document is consistent with that requirement.

Pursuant to this Order, NHTSA notes as follows. The issue of preemption is discussed above in connection with E.O. 13132. NHTSA notes further that there is no requirement that individuals submit a petition for reconsideration or pursue other administrative proceeding before they may file suit in court.

#### Unfunded Mandates Reform Act

The Unfunded Mandates Reform Act of 1995 requires agencies to prepare a written assessment of the costs, benefits and other effects of proposed or final rules that include a Federal mandate likely to result in the expenditure by State, local or tribal governments, in the aggregate, or by the private sector, of more than \$135 million annually (adjusted for inflation to 2009 dollars with base year of 1995). This NPRM would not result in expenditures by State, local or tribal governments, in the aggregate, or by the private sector in excess of \$135 million annually.

#### Plain Language

Executive Order 12866 and E.O. 13563 require each agency to write all rules in plain language. Application of the principles of plain language includes consideration of the following questions:

- Have we organized the material to suit the public's needs?
- Are the requirements in the rule clearly stated?
- Does the rule contain technical language or jargon that isn't clear?
- Would a different format (grouping and order of sections, use of headings, paragraphing) make the rule easier to understand?
- Would more (but shorter) sections be better?
- Could we improve clarity by adding tables, lists, or diagrams?
- What else could we do to make the rule easier to understand?

If you have any responses to these questions, please include them in your comments on this proposal.

#### Regulation Identifier Number (RIN)

The Department of Transportation assigns a regulation identifier number (RIN) to each regulatory action listed in the Unified Agenda of Federal Regulations. The Regulatory Information Service Center publishes the Unified Agenda in April and October of each year. You may use the RIN contained in the heading at the beginning of this document to find this action in the Unified Agenda.

#### Privacy Act

Anyone is able to search the electronic form of all comments received into any of our dockets by the name of the individual submitting the comment (or signing the comment, if submitted on behalf of an association, business, labor union, etc.). You may

review DOT's complete Privacy Act Statement in the Federal Register published on April 11, 2000 (Volume 65, Number 70; Pages 19477-78).

## **X. Public Participation**

### How do I prepare and submit comments?

Your comments must be written and in English. To ensure that your comments are correctly filed in the Docket, please include the docket number of this document in your comments.

Your comments must not be more than 15 pages long. (49 CFR 553.21). We established this limit to encourage you to write your primary comments in a concise fashion. However, you may attach necessary additional documents to your comments. There is no limit on the length of the attachments.

Comments may also be submitted to the docket electronically by logging onto the Docket Management System website at <http://www.regulations.gov>. Follow the online instructions for submitting comments.

Please note that pursuant to the Data Quality Act, in order for substantive data to be relied upon and used by the agency, it must meet the information quality standards set forth in the OMB and DOT Data Quality Act guidelines. Accordingly, we encourage you to consult the guidelines in preparing your comments. OMB's guidelines may be accessed at <http://www.whitehouse.gov/omb/fedreg/reproducible.html>.

### How can I be sure that my comments were received?

If you wish Docket Management to notify you upon its receipt of your comments, enclose a self-addressed, stamped postcard in the envelope containing your comments. Upon receiving your comments, Docket Management will return the postcard by mail.

### How do I submit confidential business information?

If you wish to submit any information under a claim of confidentiality, you should submit three copies of your complete submission, including the information you claim to be confidential business information, to the Chief Counsel, NHTSA, at the address given above under FOR FURTHER INFORMATION CONTACT. In addition, you should submit a copy, from which you have deleted the claimed confidential business information, to the docket at the address given above under ADDRESSES. When you send a comment containing information claimed to be confidential business information, you should include a cover letter setting forth the information specified in our confidential business information regulation. (49 CFR Part 512.)

Will the agency consider late comments?

We will consider all comments received before the close of business on the comment closing date indicated above under DATES. To the extent possible, we will also consider comments that the docket receives after that date. If the docket receives a comment too late for us to consider in developing a final rule (assuming that one is issued), we will consider that comment as an informal suggestion for future rulemaking action.

How can I read the comments submitted by other people?

You may read the comments received by the docket at the address given above under ADDRESSES. The hours of the docket are indicated above in the same location. You may also see the comments on the Internet. To read the comments on the Internet, go to <http://www.regulations.gov>. Follow the online instructions for accessing the dockets.

Please note that even after the comment closing date, we will continue to file relevant information in the docket as it becomes available. Further, some people may

submit late comments. Accordingly, we recommend that you periodically check the Docket for new material. You can arrange with the docket to be notified when others file comments in the docket. See [www.regulations.gov](http://www.regulations.gov) for more information.

## **XI. Proposed Regulatory Text**

### **List of Subjects in 49 CFR Part 571**

Imports, Motor vehicles, motor vehicle safety.

In consideration of the foregoing, NHTSA proposes to amend 49 CFR Part 571 as follows:

### **PART 571—FEDERAL MOTOR VEHICLE SAFETY STANDARDS**

#### **Subpart B—Federal Motor Vehicle Safety Standards**

1. The authority citation for part 571 continues to read as follows:

**Authority:** 49 U.S.C. 322, 30111, 30115, 30117, and 30166; delegation of authority at 49 CFR 1.95.

2. Section 571.227 is added to read as follows:

#### **§ 571.227 Standard No. 227; Bus Rollover Structural Integrity**

S1. Scope. This standard establishes performance requirements for bus rollover structural integrity.

S2. Purpose. The purpose of this standard is to reduce death and injuries resulting from the structural collapse of the bus body structure, the unintended opening of emergency exits, and the detachment of window glazing, seats, and overhead luggage racks.

S3. Application.

- (a) Subject to S3(b), this standard applies to:

- (1) over-the-road buses, and

(2) buses that are not over-the-road buses, and that have a GVWR greater than 11,793 kilograms (26,000 pounds).

(b) This standard does not apply to school buses, transit buses, and perimeter-seating buses.

#### S4. Definitions.

Anchorage means any component involved in transferring loads to the vehicle structure, including, but not limited to, attachment hardware, frames, and vehicle structure itself.

Over-the-road bus means a bus characterized by an elevated passenger deck located over a baggage compartment.

Perimeter-seating bus means a bus with 7 or fewer designated seating positions rearward of the driver's seating position that are forward-facing or can convert to forward-facing without the use of tools and is not an over-the-road bus.

Stop-request system means a vehicle-integrated system for passenger use to signal to a vehicle operator that they are requesting a stop.

Survival space means a three-dimensional space to be preserved in the occupant compartment during the rollover structural integrity test. The survival space is all points within the following volume of the occupant compartment:

(1) The front boundary of the survival space is a transverse vertical plane 600 mm in front of the forward most point on the centerline of the front surface of the seat back of the forward most seat when the seat is in its forward most position and the seat back is in the manufacturer's nominal design riding position.

(2) The rear boundary of the survival space is the inside surface of the rear wall of the occupant compartment of the vehicle.

(3) The outer boundary of the survival space at any transverse cross section between or at the front and rear boundaries is defined on each side of the vehicle by the following three line segments:

(i) Segment 1 extends vertically from the floor to an end point that is 500 mm above the floor and 150 mm inboard of the side wall.

(ii) Segment 2 starts at the end point of Segment 1. The end point of Segment 2 is 750 mm vertically above and 250 mm horizontally inboard of the end point of Segment 1.

(iii) Segment 3 is a horizontal line that starts at the end point of Segment 2 and ends at the vertical longitudinal center plane of the vehicle.

Survival space template means a structure that represents a vertical transverse cross section of the survival space as shown in Figure 1. The structure is a minimum of 15 mm thick and secured by a rigid support frame that allows attachment to the vehicle floor.

Transit bus means a bus that is equipped with a stop-request system sold for public transportation provided by, or on behalf of, a State or local government and that is not an over-the-road bus.

S5. Requirements. When tested under the conditions and procedures specified in S6, each bus shall meet the following:

S5.1 No part of the vehicle which is outside the survival space shall intrude into the survival space during the movement of the tilting platform or resulting from impact of the vehicle on the impact surface.

S5.2 Each anchorage of all vehicle seats and interior overhead luggage racks and compartments shall not completely separate from its mounting structure during the

movement of the tilting platform or resulting from impact of the vehicle on the impact surface.

S5.3 Emergency exits shall not open during the movement of the tilting platform or resulting from impact of the vehicle on the impact surface.

S5.4 After the vehicle comes to rest on the impact surface, with the vehicle resting on its side, each roof and rear emergency exit of the vehicle provided in accordance with Standard No. 217 (§ 571.217) shall be capable of releasing and opening according to the requirements specified in that standard.

S5.5 After the vehicle comes to rest on the impact surface, with the vehicle resting on its side, window glazing and each surrounding window frame opposite the impacted side of the vehicle shall not allow the passage of a 102 mm diameter sphere when a force of no more than 22 Newtons is applied to the sphere at any vector in a direction from the interior to the exterior of the vehicle.

#### S6. Test conditions.

##### S6.1 Tilting platform.

S6.1.1 The tilting platform has a top surface that rests horizontally at its initial position and is of sufficient size to fully contact the bottom of the vehicle's tires.

S6.1.2 The top surface of the tilting platform, at its initial position, is  $800 \pm 20$  millimeters (mm) above the impact surface specified in S6.1.6.

S6.1.3 The axis of rotation of the tilting platform is a maximum of a 100 mm horizontal distance from the edge of the impact surface closest to the platform and a maximum of 100 mm below the horizontal plane at the top surface of the tilting platform as shown in Figure 3.



S6.1.4 The tilting platform is equipped with wheel supports on the top surface as shown in Figure 3. At each vehicle axle, the wheel closest to the platform's axis of rotation is supported. The wheel supports are positioned to make contact with the outboard tire sidewall of the supported wheels with the vehicle positioned as specified in S6.3.1. Each wheel support has the following dimensions:

- (a) The height above the top surface of the tilting platform is no greater than two-thirds of the vertical height of the adjacent tire's sidewall.
- (b) The width is a minimum of 19 mm.
- (c) The length is a minimum of 500 mm.
- (d) The top inboard edge has a radius of 10 mm.

S6.1.5 While raising the platform, the tilting platform roll angle, measured at the outside of each wheel farthest from the pivot point, does not differ by more than one degree.

S6.1.6 The impact surface is horizontal, uniform, dry, and smooth concrete. The impact surface covers an area that is large enough to ensure that the vehicle does not strike beyond the impact surface edges.

## S6.2 Vehicle preparation.

S6.2.1 The vehicle's tires are inflated to the manufacturer's recommended tire pressure.

S6.2.2 Survival space templates may be secured to the bus floor anywhere within the survival space.

S6.2.3 If a seat has adjustable anchorages, the seat may be moved forward or rearward to allow the installation of a survival space template. If a seat has fixed anchorages, the seats may be removed to allow the installation of any testing equipment.

Ballast of any weight up to the weight of the removed seat and 68 kg per designated seating position may be secured to the bus floor. The ballasts are not placed farther forward than the forward most point of the vehicle seat immediately in front of the removed seat, and the ballasts are not placed farther rearward than the rear most point of the vehicle seat immediately behind the removed seat.

S6.2.4 The fuel tank is filled to its maximum fuel capacity. All other vehicle fluids are at their maximum capacity. Fluids may be substituted if the weight of the original fluid is maintained.

S6.2.5 Ballasting. The vehicle is loaded to any weight up to and including the gross vehicle weight rating (GVWR). Up to 68 kg of ballast is installed at all designated seating positions that are equipped with occupant restraints. The ballast is placed on the top of each seat cushion and attached securely to the seat frame such that it does not break away from the seat from the time the tilting platform begins movement to after the vehicle comes to rest on the impact surface.

S6.3 Rollover structural integrity test procedure. Each vehicle shall meet the requirements of S5 when prepared as specified in S6.2 and tested in accordance with the procedures set forth below.

S6.3.1 Position the vehicle on the tilting platform as illustrated in the examples of Figures 2 and 3 with its longitudinal centerline parallel to the tilt platform's axis of rotation, the right or left side facing the impact surface at NHTSA's option, and with the outboard tire sidewall at the widest axle within 100 mm of the axis of rotation.

S6.3.2 Attach a rigid wheel support to the tilting platform at each axle of the vehicle so that it contacts the outboard tire sidewall of the wheel closest to the impact surface.

S6.3.3 Block the suspension system of the vehicle to be within  $\pm 25$  mm of the normal riding attitude as loaded in S6.2.5.

S6.3.4 Apply the vehicle parking brakes.

S6.3.5 Place the vehicle windows, doors, and emergency exits in the fully closed and latched but not locked positions.

S6.3.6 Tilt the vehicle at a rate not to exceed 5 degrees/sec until it starts to rollover on its own.

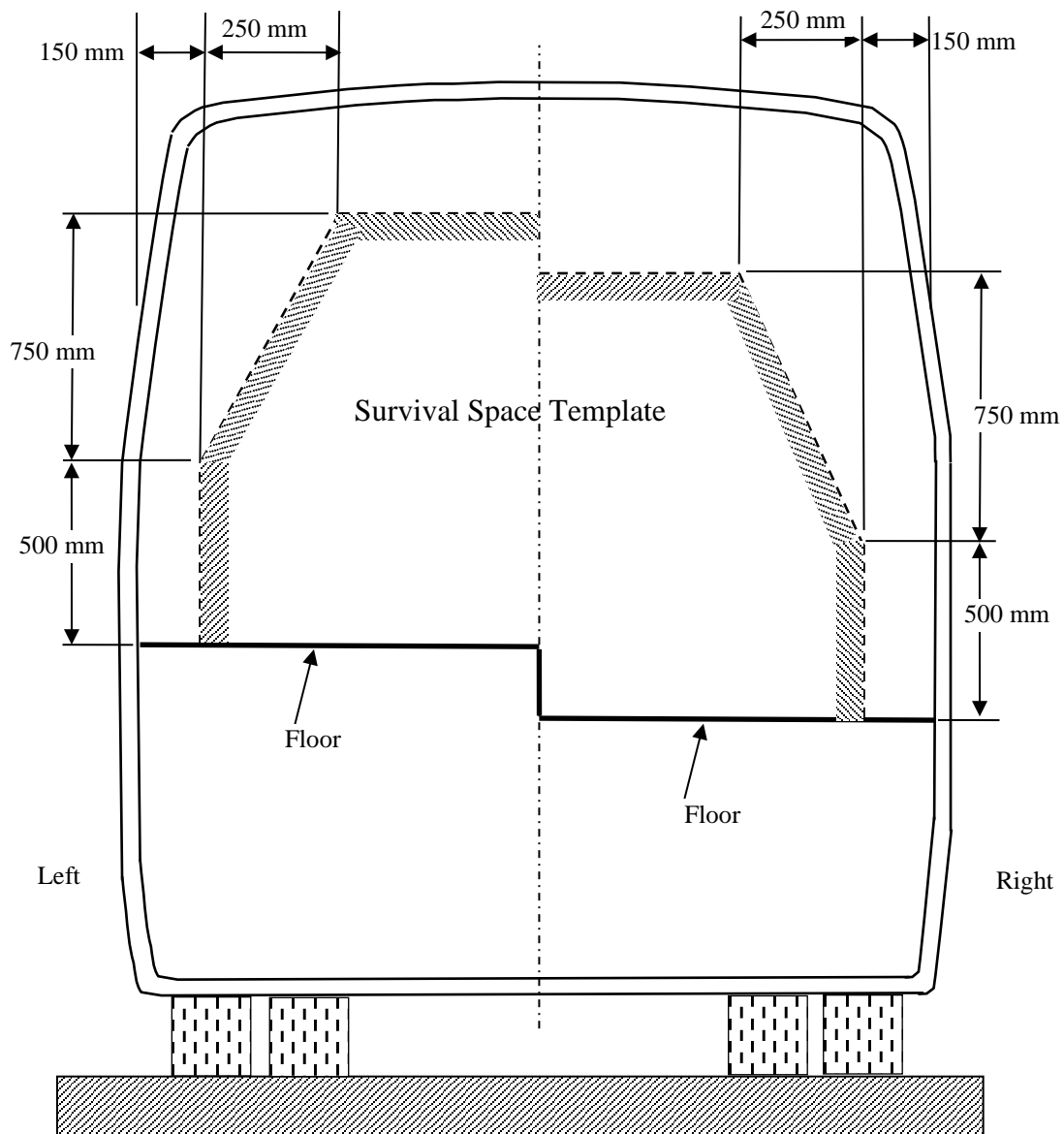

Figure 1: Survival Space Template  
(Illustration Purposes)

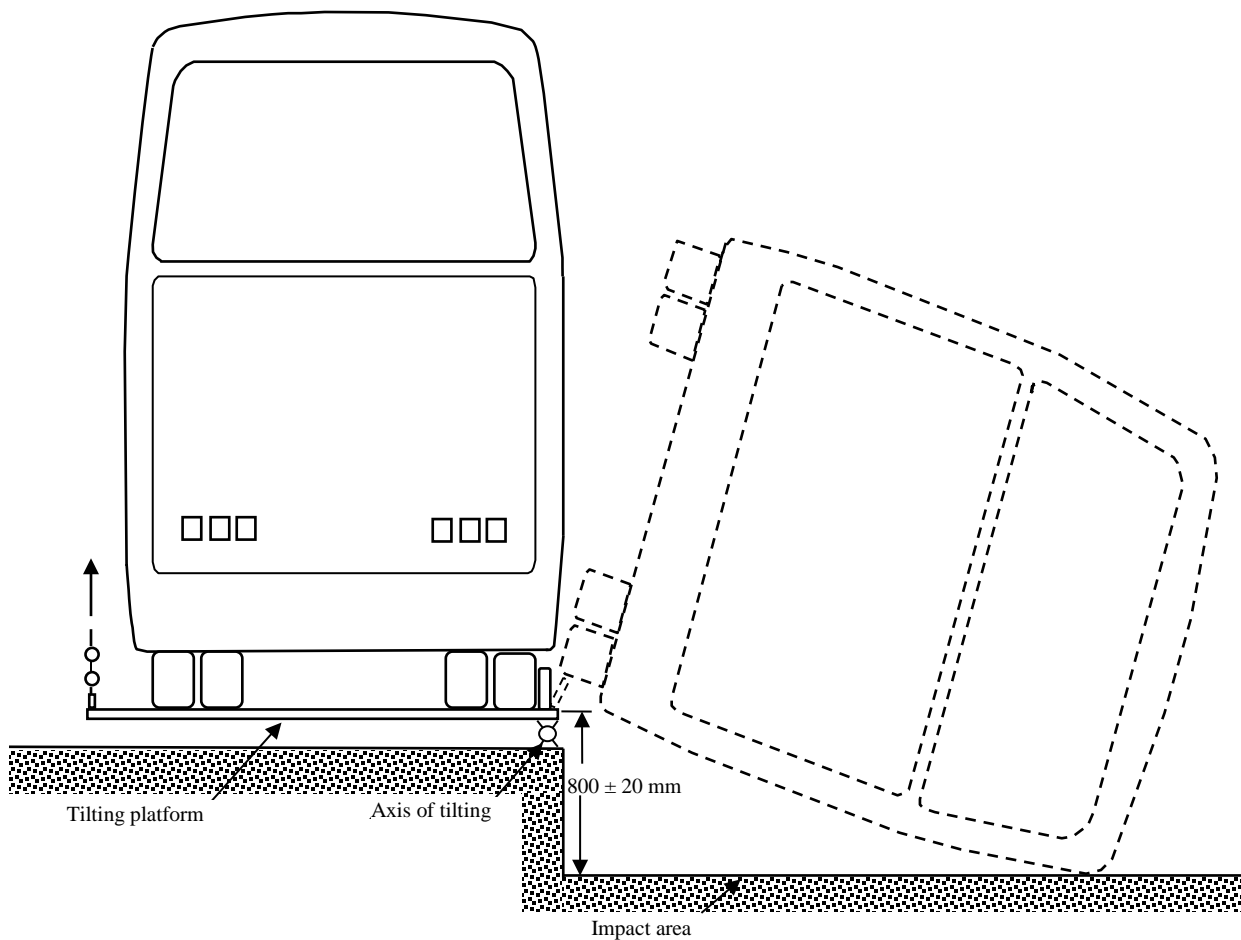

Figure 2: Vehicle on Tilting Platform  
(Illustration Purposes)

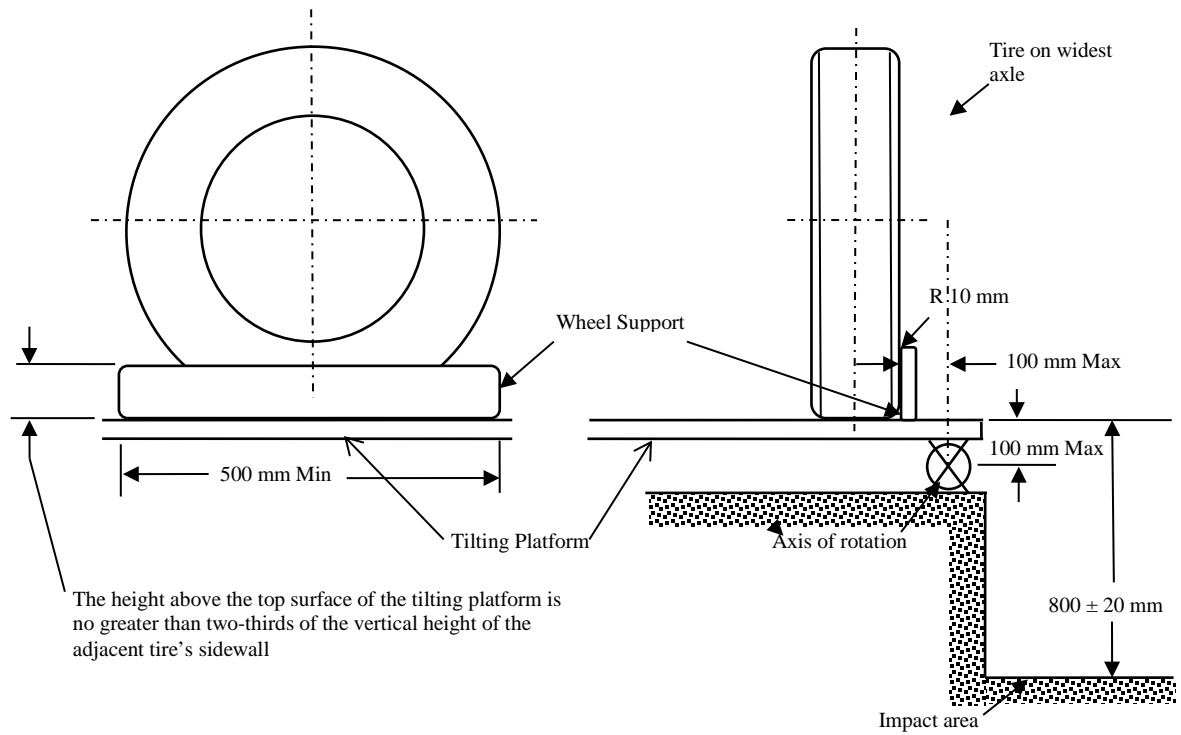

Figure 3: Axis of Rotation  
(Illustration Purposes)

Issued in Washington, DC on:

under authority delegated in 49 CFR part 1.95.

---

David M. Hines  
Acting Associate Administrator  
for Rulemaking

Billing Code: 4910-59-P

[Signature page for Structural Integrity- Motorcoaches NPRM]